

# Kinetic Aspects of the Interaction of Blood Clotting Enzymes

## *I. Derivation of Basic Formulas*

*From the Haematology Section of the Department of Internal Medicine  
(Head: Prof. J. Mulder, M.D.), University Hospital,  
and the Thrombosis Service (Head: E. A. Loeliger, M.D.),  
Leyden, The Netherlands.*

H. C. HEMKER, P. W. HEMKER and E. A. LOELIGER

## **I. Introduction**

When a process involving enzyme-catalysis is studied, the measurement of the reaction-velocity under different conditions (such as enzyme and substrate concentration) and different physical variables (such as pH, temperature, ionic strength, etc.) yields a wealth of information. The interpretation of this information – the study of enzyme kinetics – has substantially deepened our insight into the mechanism of action of enzymatic catalysis.

The blood-clotting process consists of a very complicated sequence of enzyme actions. The conditions under which the blood-clotting enzymes operate differ in some essential points from the standard conditions, which are assumed to be fulfilled when “ordinary” enzyme kinetics apply. Some of the consequences of these differences will be discussed in this article.

Although not too much is known about the reaction mechanism of the blood-clotting process, we do know enough to predict that an exact kinetic treatment of this process by means of relatively simple mathematics, as we aim to do here, is impossible without introducing gross simplifications. The logical consequence would be to drop the kinetic approach and stick to the well-known empirical relationships, such as the rectilinear relation that should exist between the logarithm of the concentration of the clotting-factor to be tested and the logarithm of the observed clotting-time. Such relations are of course important practical tools, but they have the disadvantage that they do not provide insight into the mechanism of the reaction studied. Possible implications of the linearity on a  $\log C - \log t$  plot will be discussed below.

In an attempt to apply enzyme kinetics to the clotting-process we have found that this process sometimes behaves as if it were a much simpler system than we knew it to be. This enabled us to obtain information about this seemingly simple process, since we knew that it represents a function of the reaction-sequence of blood-clotting. Thus there is a possibility that, although blood-clotting as a whole is too complicated for a concise kinetic treatment, the study of simplified parts of the system will yield useful information. The bases of enzyme kinetics, as given sub II, V, and VI, are taken from ref. 1 and 2. The symbols and nomenclature are the same as those in ref. 4. As far as the nomenclature of the blood-clotting factors is involved, we follow the suggestions of the International Committee for the Nomenclature of blood-clotting factors (ref. 3).

## II. The Standard Model of Enzyme Kinetics

Classical enzyme kinetics are based upon the assumption that enzyme-molecules (E) in a solution containing an excess of substrate molecules (S) react reversely with these substrate molecules to form the enzymesubstrate complex (C). This complex dissociates irreversibly into enzyme and product (P). Each of these reactions has its own reaction constant ( $k$ ).

In formula :



Assuming ( $\alpha$ ) that the amount of substrate is much greater than the amount of enzyme we can put:

$$\text{E}_t = \text{E} + \text{C} \quad (1)$$

$$\text{S}_t \approx \text{S} \quad (2)$$

in which  $\text{E}_t$  is the total amount of enzyme and  $\text{S}_t$  the total amount of substrate added to the reaction medium<sup>1)</sup>.

Further it is assumed ( $\beta$ ) that the amount of C will be constant during a certain time after the reaction has been started. Then the production rate of C ( $v_{+1}$ ) will be equal to the disappearance rate,  $v_{-1} + v_{+2}$ .

$$v_{+1} = v_{-1} + v_{+2} \quad (3)$$

Finally ( $\gamma$ ) only initial rates are considered, i. e. the decline of reaction-velocity due to the decline of substrate concentration (because of its conversion to

1) In the reaction schemes E, C, and S denote molecules. In the mathematical formulas E, C, and S denote the concentration of these molecules.

product) is not taken into account. Under these conditions ( $\alpha, \beta, \gamma$ ) the velocity of product formation ( $v$ ) can be derived in the following way:

$$v = v_{+2} = k_{+2} \cdot C \quad (4)$$

$$(3) \quad \rightarrow k_{+1} \cdot E \cdot S = (k_{-1} + k_{+2}) \cdot C \quad (5)$$

$$(1) \ \& \ (2) \ \& \ (3) \ \rightarrow k_{+1} \cdot E_t \cdot S_t = C \cdot (k_{-1} + k_{+2} + k_{+1} \cdot S_t) \quad (6)$$

$$(4) \ \& \ (6) \quad \rightarrow v_{+2} = \frac{k_{+2} \cdot k_{+1} \cdot E_t \cdot S_t}{(k_{-1} + k_{+2} + k_{+1} \cdot S_t)} \quad (7)$$

$$\text{or:} \quad \frac{1}{v} = \frac{k_{-1} + k_{+2}}{k_{+1}} \cdot \frac{1}{k_{+2} \cdot E_t} \cdot \frac{1}{S_t} + \frac{1}{k_{+2} \cdot E_t} \quad (7')$$

$$\text{and as} \quad \frac{k_{-1} + k_{+2}}{k_{+1}} = K_m:$$

$$\frac{1}{v} = K_m \cdot \frac{1}{k_{+2} \cdot E_t} \cdot \frac{1}{S_t} + \frac{1}{k_{+2} \cdot E_t} \quad (7'')$$

The most convenient way to render this formula graphically, is to plot  $\frac{1}{v}$  against  $\frac{1}{S}$ , which gives a straight line [the so-called Lineweaver-Burk plot; (ref. 5) (Fig. 1)].

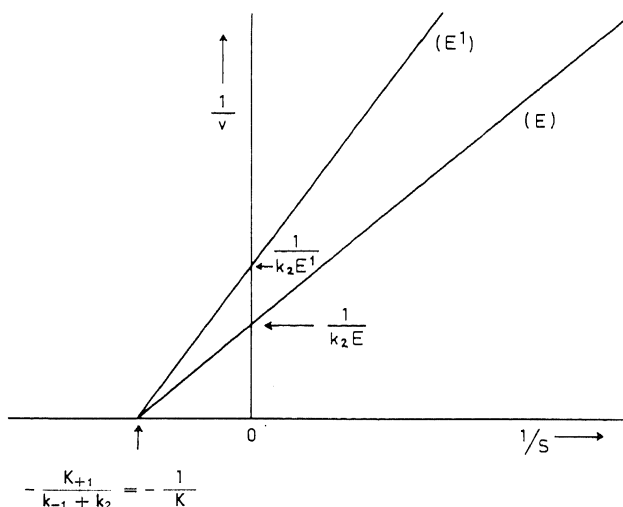

Fig. 1. The Lineweaver-Burk plot. The relationship between  $\frac{1}{v}$  and  $\frac{1}{S}$  is shown for two different concentrations of enzyme (E and E').

(Note:  $k_1 = k_{+1}$ , etc.;  $K = K_m$ .)

III. A Model of the Clotting Process

In accordance with Biggs and Macfarlane (ref. 6, 7) and Macfarlane, Owren and Lüscher (ref. 3) we will consider the clotting process as a series of protein interactions, in which each clotting-factor is in turn substrate to the action of the previous one, and the enzyme catalysing the conversion of the next one (Fig. 2).

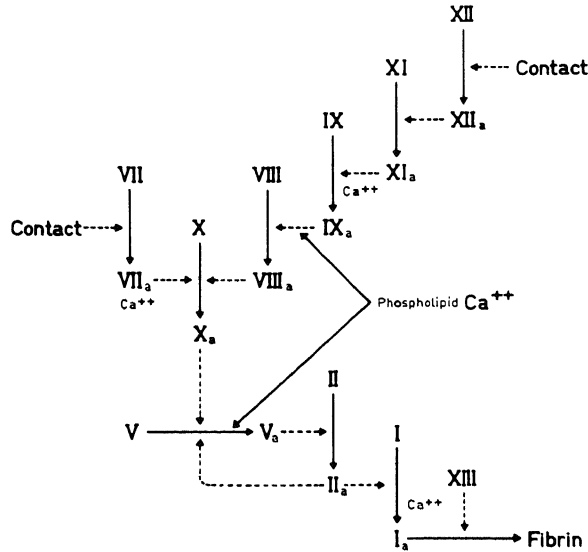
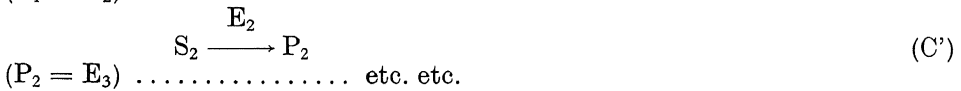

Fig. 2. A scheme of the interaction of blood-clotting factors.

In formula :



In this example  $E_1$  can e.g. be activated F.XII; then  $S_1 = F.XI$ , and  $E_2 = P_1 =$  activated F. XI, etc.

Already this is a gross simplification, as the role of dialysable factors (e.g.  $Ca^{++}$ ) is not taken into account and because all relations are supposed to be irreversible. Nor is the possibility considered that reactions occur of the type:



Further enzyme inactivation mechanisms are ignored, as are inhibitions by excess of substrate or product. Still, this simple view already explains much of the peculiarities of the clotting process.

One step of the reaction-sequence depicted above differs considerably from the standard model of enzyme kinetics. As both substrate and enzyme are proteins, the concentrations of which are probably of the same order of magnitude, the assumption that there is an excess of substrate is no longer valid. The consequences of sequential coupling of these reactions will be discussed later.

#### IV. The Reaction-Velocity of the Clotting Process

The velocity of the clotting process ( $v$ ) is commonly deduced from the clotting-time ( $t$ ). This is the time necessary for a critical concentration ( $C$ ) of fibrin monomere to be formed. This critical concentration is the concentration of monomere necessary to obtain visible fibrin formation. Since the polymerization of fibrin monomere is a nonenzymatic process, the concentration of monomere necessary to obtain visible polymerization will be equal under equal physical conditions. This implies that the reaction-velocity of monomere formation will be inversely proportional to the clotting-time.

$$t \cdot v = C \text{ or } \frac{1}{v} = \frac{t}{C} \quad (8)$$

In this reasoning we have tacitly assumed that an instantaneous and clearly visible change in liquidity is observed when the fixed concentration  $C$  is depassed.

In reality, this coagulation in the stricter sense requires a finite time to be completed, and this time in itself is dependent upon the coagulation-velocity. So, the moment at which coagulation is detected is only an arbitrarily chosen point in the process. To obtain reproducible results requires much training, or rigorous standardization of the criterion of fibrin formation as realised in the coagulometer (ref. 8, 9).

#### V. Kinetics of One Step of the Clotting Process

It must be assumed that in a reaction which is a part of the clotting process (except possibly the fibrinogen conversion) the concentrations of enzyme and substrate are of the same order of magnitude, since each substrate will turn into enzyme in the next stage of the process. It is, for instance, not very conceivable that factor XI will be present in a concentration much greater than the concentration of factor XII and yet a concentration much smaller than that of factor IX.

When in the reaction-sequence:



the supposition:

$\text{S} \gg \text{E}$  is not valid; we must put:

$$\text{E}_t = \text{E} + \text{C} \quad (1)$$

$$\text{S}_t = \text{S} + \text{C} \quad (9)$$

(instead of:  $\text{S}_t \approx \text{S}$ ) (2)

This leads to equation 10, via a reasoning analogous to that sub II:

$$v = \frac{1}{2} k_{+2} [(\text{S}_t + \text{E}_t + K_m) \pm \sqrt{(\text{S}_t + \text{E}_t + K_m)^2 - 4 \text{S}_t \cdot \text{E}_t}] \quad (10 \text{ a. b.})$$

We can drop the formula:

$$v = \frac{1}{2} k_{+2} [(\text{S}_t + \text{E}_t + K_m) + \sqrt{(\text{S}_t + \text{E}_t + K_m)^2 - 4 \text{S}_t \cdot \text{E}_t}] \quad (10 \text{ a})$$

because we know that  $v = 0$  when  $\text{S}_t = 0$  and  $\text{E}_t = 0$ .

Now, substitution of  $\text{S}_t = 0$  and  $\text{E}_t = 0$  in equation 10 a gives:

$$v = \frac{1}{2} k_{+2} [(0 + 0 + K_m) + \sqrt{(0 + 0 + K_m)^2 - 4 \cdot 0 \cdot 0}] \quad (11)$$

$\rightarrow v = k_{+2} \cdot K_m$  which is not true. Remains:

$$v = \frac{1}{2} k_{+2} [(\text{S}_t + \text{E}_t + K_m) - \sqrt{(\text{S}_t + \text{E}_t + K_m)^2 - 4 \text{S}_t \cdot \text{E}_t}] \quad (10 \text{ b})$$

We can replace the square root because:

$$\sqrt{(\text{S}_t \cdot \text{E}_t \cdot K_m)^2 - 4 \text{S}_t \cdot \text{E}_t} = (\text{S}_t + \text{E}_t + K_m) \sqrt{1 - \frac{4 \text{S}_t \cdot \text{E}_t}{(\text{S}_t + \text{E}_t + K_m)^2}}$$

$$\approx (\text{S}_t + \text{E}_t + K_m) \left(1 - \frac{2 \text{S}_t \cdot \text{E}_t}{(\text{S}_t + \text{E}_t + K_m)^2}\right) =$$

$$\text{S}_t + \text{E}_t + K_m - \frac{2 \text{S}_t \cdot \text{E}_t}{\text{S}_t + \text{E}_t + K_m}$$

(This is only valid when  $(\text{S}_t + \text{E}_t + K_m)^2 \gg \text{S}_t \cdot \text{E}_t$ , which is true in our case.)

Substitution of the square root in equation 10 b gives:

$$v = \frac{k_{+2} \cdot \text{S}_t \cdot \text{E}_t}{\text{S}_t + \text{E}_t + K_m} \quad (12)$$

or:

$$\frac{1}{v} = \frac{\text{S}_t + \text{E}_t + K_m}{k_{+2} \cdot \text{S}_t \cdot \text{E}_t} = \frac{1}{\text{S}_t} \cdot \frac{\text{E}_t + K_m}{k_{+2} \cdot \text{E}_t} + \frac{1}{k_{+2} \cdot \text{E}_t}$$

$$\frac{k_{+2}}{v} = \frac{1}{E_t} + \frac{1}{S_t} + \frac{K_m}{E_t \cdot S_t} \quad (12')$$

Here too,  $\frac{1}{v}$  is in linear dependence on  $\frac{1}{S_t}$ .

This implies that a plot analogous to the Lineweaver-Burk plot can be used when  $S_t \approx E_t$ . Some properties of the graph obtained when plotting in this way are shown in Fig. 3. (From now on the indexes t and m will be omitted when no confusion can occur.)

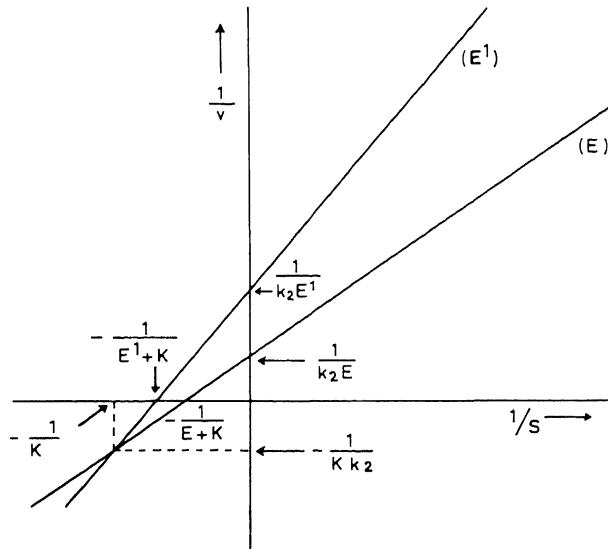

Fig. 3. The Lineweaver-Burk plot under modified conditions. The relationship between  $\frac{1}{v}$  and  $\frac{1}{S}$  is shown for two different concentrations of enzyme (E and E') under conditions where  $S \gg E$  is not valid.

When:

$$\frac{1}{S} = 0 \text{ follows: } \frac{1}{v} = \frac{1}{k_{+2} \cdot E}; \text{ -- as in the classical formula --.}$$

When:

$$\frac{1}{v} = 0 \text{ follows: } \frac{1}{S} = -\frac{1}{E + K}; \text{ -- contrary to the classical formula,}$$

where:

$$\frac{1}{S} = -\frac{1}{K}.$$

When two graphs of the type  $\frac{1}{v} = f\left(\frac{1}{S}\right)$  differ only as to the amount of enzyme added, they intercept in the point (a, b) in the third quadrant.

$$b = a \cdot \frac{E + K}{k_{+2} \cdot E_1} + \frac{1}{k_{+2} \cdot E_1} \quad (13)$$

$$b = a \cdot \frac{E + K}{k_{+2} \cdot E_2} + \frac{1}{k_{+2} \cdot E_2} \quad (14)$$

$$a = - \frac{\frac{1}{k_{+2} \cdot E_2} - \frac{1}{k_{+2} \cdot E_1}}{\frac{E_2 + K}{k_{+2} \cdot E_2} - \frac{E_1 + K}{k_{+2} \cdot E_1}} = \frac{E_1 - E_2}{K \cdot E_1 - K \cdot E_2} = - \frac{1}{K} \quad (15)$$

$$b = - \frac{1}{K} \cdot \frac{E_1 + K}{k_{+2} \cdot E_1} + \frac{1}{k_{+2} \cdot E_1} = - \frac{1}{K \cdot k_{+2}} \quad (16)$$

So (a, b) is independent of E, and all lines representing  $\frac{1}{v} = f\left(\frac{1}{S}\right)$  will intercept at the point  $\left(-\frac{1}{K}, -\frac{1}{k_{+2} \cdot K}\right)$ .

Thus variation of the enzyme concentration will result in a bundle of lines all passing through the point  $-\frac{1}{K \cdot k_{+2}} \cdot -\frac{1}{K}$  in the third quadrant. Further consideration of equation 12 shows that S and E are located at symmetrical places; so S and E can be interchanged without changing the sense of the equation.

This means that  $\frac{1}{v}$  is in a linear relationship to  $\frac{1}{E}$  when S is constant, just as it is in a linear relationship to  $\frac{1}{S}$  when E is constant. This is an important difference from the classical formula, in which the relationship between  $v$  and E is linear.

Plotting of  $\frac{1}{v}$  against  $\frac{1}{E}$  for different values of S will also give a bundle of lines intercepting at the point  $\left(-\frac{1}{K}, -\frac{1}{k_{+2} \cdot K}\right)$ .

The fact that the coordinates of this point are equal in both the  $\frac{1}{v}$  against  $\frac{1}{E}$  and the  $\frac{1}{v}$  against  $\frac{1}{S}$  plot gives us a method to compare the concentration of E and S on a molar basis.



In the following consideration the component of which the concentration is varied will by definition be called Substrate, and the constant component will be called Enzyme. This does not mean to say that it is the component Substrate which is converted into the product.

When both enzyme and substrate are diluted at the same time, as is the case when they are present in the sample to be tested and not in the "reagent" we can work out the following relationships:

$$\frac{E}{S} = n; E = n \cdot S \quad (17)$$

(n = constant)

$$\text{So: } v = \frac{k_{+2} \cdot n \cdot S^2}{(n + 1) \cdot S + K} \quad (18)$$

$$\frac{1}{v} = \frac{1}{S} \cdot \left( \frac{n + 1}{k_{+2} \cdot n} + \frac{K}{k_{+2} \cdot n} \cdot \frac{1}{S} \right) \quad (19)$$

$$\frac{S}{v} = \frac{K}{k_{+2} \cdot n} \cdot \frac{1}{S} + \frac{n + 1}{k_{+2} \cdot n} \quad (19')$$

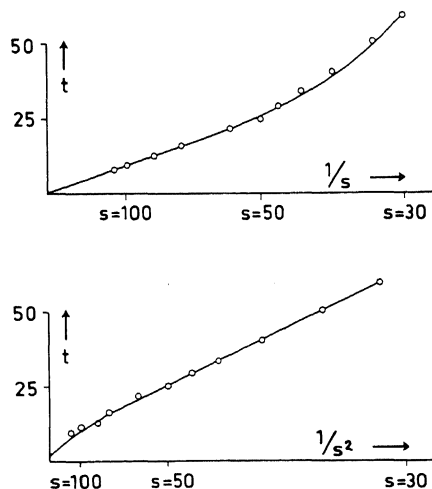

Fig. 4. *The interaction of thrombin and fibrinogen.* The final concentration of fibrin is given in mg%, the clotting time in seconds.

Reaction medium: 0.1 ml fibrin to the concentration desired; 0.1 ml thrombin "Roche" 300 i.u. dissolved in Michaelis buffer pH 7.4.

An alternative explanation to these results is the following reaction mechanism:  $E + S \rightleftharpoons E \cdot S$ ;  $E \cdot S + S \rightleftharpoons E \cdot S \cdot S$ ;  $E \cdot S \cdot S \rightarrow E + P - P$ .

This would mean a first polymerization of fibrin on the enzyme rather than an independent polymerization of fibrin monomers.

$$\text{When } \frac{K}{S} \gg n + 1 \text{ then } \frac{1}{v} \approx \frac{1}{S^2} \cdot \frac{K}{k_{+2} \cdot n} \text{ is true.} \quad (20)$$

$$\text{When } \frac{K}{S} \ll n + 1 \text{ then } \frac{1}{v} \approx \frac{n + 1}{k_{+2} \cdot n} \cdot \frac{1}{S} \text{ is true.} \quad (21)$$

This shows that in this case we get a graph which in good approximation runs through the origin, and which will be straight in the neighbourhood of the origin, whereas at the right of the plot it will resemble a parabola. In practice this parabola can be recognized by plotting  $\frac{1}{v}$  against  $\frac{1}{S^2}$ , which will give a straight line.

Possibly the data obtained from the action of partly purified thrombin on partly purified fibrinogen are an illustration of this case (Fig. 4).

## VI. The Effect of the Disappearance of Substrate during the Clotting - Time

We assume that a test-system is chosen in such a way that only the factor to be tested is rate limiting, and that only the concentration of the factor to be tested is varied, while all the other factors are present in excess. Even in that case, estimation of the initial reaction-velocity from the clotting-time is possible only when the reaction rate does not change much during that time due to substrate disappearance.

Of course, product formation will result in substrate disappearance, and so the reaction-velocity will decrease during the time that elapses before clotting is observed. We now will consider whether this disappearance affects our estimation of the reaction-velocity.

From the known formula of the reaction-velocity the relation between the amount of product formed at the time  $t$  ( $P_t$ ) and the amount of substrate originally present ( $S_0$ ) can be calculated.

$$-\frac{dS}{dt} = \frac{k_{+2} \cdot E \cdot S}{K + E + S} \quad (12) \quad (22)$$

$$\left(1 + \frac{K}{S} + \frac{E}{S}\right) \cdot dS = -k_{+2} \cdot E \cdot dt \quad (23)$$

$$\int_{S_0}^{S_t} \left(1 + \frac{K + E}{S}\right) \cdot dS = - \int_0^t k_{+2} \cdot E \cdot dt \quad (24)$$

$$S_t - S_0 + (K + E) \cdot \ln \frac{S_t}{S_0} = k_{+2} \cdot E \cdot t \quad (25)$$

Now, since:

$$\frac{S_0 - S_t}{S_0} \approx 1, \text{ it follows that:}$$

$$\ln \frac{S_t}{S_0} \approx \frac{S_t - S_0}{S_0} \quad (26)$$

$$S_0 : S - S_0 + (K + E) \left( \frac{S - S_0}{S_0} \right) = -k_{+2} \cdot E \quad (27)$$

$$\text{or: } P_t (1 + (K + E) \cdot \frac{1}{S_0}) = -k_{+2} \cdot E_t$$

$$P_t (S_0 + K + E) = -k_{+2} \cdot E_t \cdot S_0$$

$$P_t = -\frac{k_{+2} \cdot E_t \cdot S_0}{S_0 + K + E} \quad (28)$$

This will be true up to the moment that the approximative value of the logarithmic term ( $\frac{S_0 - S_t}{S_0}$ ) differs less from the real value than the small amount that cannot be detected because it is obscured by the experimental error ( $e$ ). The difference between  $\ln \frac{S}{S_0}$  and  $\frac{S_0 - S_t}{S_0}$  will be less than  $\frac{1}{2} \left( \frac{S_0 - S_t}{S} \right)^2$  (because  $\frac{1}{2} \left( \frac{S_0 - S_t}{S} \right)^2$  is the next term in the series development of  $\ln \frac{S}{S_0}$ ).

This implies that when  $\frac{1}{2} \left( \frac{P_t}{S_0} \right)^2$  is smaller than or equal to twice the standard deviation, the rest of the series development will have no measurable influence on the interpretation of the results.

So, as long as  $\frac{1}{2} \left( \frac{P_t}{S_0} \right)^2$  remains smaller than  $e$  we may assume the interrelation between  $P$  and  $v$  to be rectilinear.

This shows that at the usual experimental error of 2%, coagulation time is a fairly good measure for initial clotting reaction-velocity, when it can be assumed that at the moment of clotting not more than  $\sqrt{2 \cdot \frac{2}{100}} = 20\%$  of the initial amount of the clotting-factor to be tested is consumed. In practice this condition will be fulfilled for factors I, II, VII, IX, X, XI, and XII. No details are known as to the behaviour of factors V and VIII in this respect. Generally spoken, disappearance of substrate will not be a serious drawback to the application of a Lineweaver-Burk plot in the evaluation of clotting tests.

### VII. The Clotting Time – Dilution Plot ( $t$ - $D$ · Plot)

Since for clotting-factors the exact concentration expressed in molar units is always unknown, it is impossible to put the inverse of substrate concentration along the X-axis, as is to be done in the Lineweaver-Burk plot.

When we estimate a clotting-time in a system which contains 100% of the clotting-factor to be tested, we can enter the value obtained ( $t_{100:1}$ ) in a rectangular coordinate system at a distance  $t_{100:1}$  from the abscissa and at a distance  $D = 1$  from the ordinate, 1 being an arbitrarily chosen unit of length. Now we estimate the clotting time in an analogous system, containing only 50% of the clotting-factor to be tested. This clotting-time ( $t_{100:2}$ ) we plot at a distance of  $2l$  from the ordinate. In practice this set-up is realized when we add undiluted (dilution factor  $D = 1$ ), twice diluted ( $D = 2$ ), three times diluted ( $D = 3$ ), etc. normal plasma to a reagent containing all necessary factors in excess except the factor to be tested, which it does not contain at all. The complications introduced when the reagent *does* contain the factor to be tested will be discussed later. The resulting graph is directly comparable to the Lineweaver-Burk plot, because when a plasma is diluted  $n$  times and so contains  $100/n\%$  of the factor, the corresponding clotting-time (inverse of reaction-velocity) is plotted at a distance  $n \times 1$  from the ordinate, so the distance from the ordinate will be inversely related to the substrate concentration. When we start the procedure

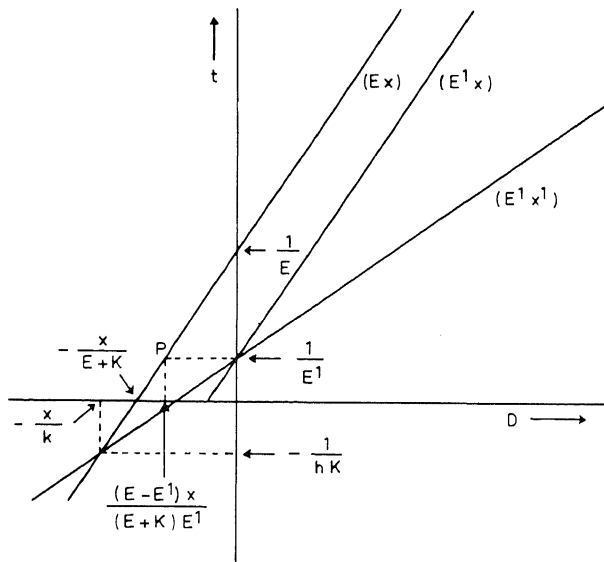

Fig. 5. The clotting time – dilution plot. The relationship between  $t$  and  $D$  is shown for two different concentrations of substrate ( $x$  and  $x'$ ) and for two different concentrations of enzyme ( $E$  and  $E'$ ).

with plasmas containing less than 100% of the clotting-factor, we will get a line that runs steeper than the line obtained with normal plasma. It can be easily seen that the steepness of two lines reflects their relative concentrations; more exactly (Fig. 5), that the direction coefficient of the lines obtained is inversely related to the concentration of the clotting-factor in the starting plasma. The lines obtained with different starting plasmas will, however, all intercept at the same point on the ordinate, because this point indicates the clotting-time that would be obtained when an infinite concentration of substrate is added (a dilution factor of zero) and of course this minimal clotting-time ( $t_{\min}$ ) must be equal, no matter from what series the value has been extrapolated. It must be observed that two lines which differ because of the fact that the original plasmas contained different amounts of substrate would coincide in a real Lineweaver-Burk plot, and are different only because of the fact that the scale on the abscissa has a unit of length which is the inverse of the substrate concentration in the undiluted plasma.

So  $\frac{1}{v}$  is not plotted against  $\frac{1}{S}$  as in the Lineweaver-Burk plot but  $t$  ( $\sim \frac{1}{v}$ ) is plotted against the dilution (D).

The substrate concentration in a given sample will be equal to the substrate concentration in the original plasma divided by the dilution factor.

When the amount of clotting-factors present in a plasma is expressed as a fraction (x) of the amount present in normal plasma (so when the plasma contains 27% of a given factor,  $x = \frac{27}{100}$ ) then the substrate concentration in a given sample will be:

$$S = \frac{x}{D} \quad (29)$$

So our basic formula will change from:

$$\frac{k_{+2}}{v} = \frac{1}{E} + \frac{1}{S} + \frac{K}{E \cdot S} \quad (12')$$

$$\text{into: } t \cdot h = \frac{1}{E} + \left(1 + \frac{K}{E}\right) \cdot \frac{D}{x} \quad (30)$$

where: t = clotting-time

h = a constant

E = enzyme concentration

K = a reaction constant

x = the amount of clotting-factors in the original plasma, expressed as a fraction from a standard amount

D = dilution factor

[In practice we see that, for instance, the reference curve of Owren's thrombotest becomes a straight line when plotted in this way (ref. 10, 11)].

Some of the properties of the graph thus obtained are:

a) Intercept with the ordinate: ( $D = 0$ )

$$t \cdot h = \frac{1}{E} + \left(1 + \frac{K}{E}\right) \cdot \frac{0}{x}$$

$$t = \frac{1}{E \cdot h} \quad (31)$$

b) Intercept with the abscissa: ( $t = 0$ )

$$0 = \frac{1}{E} + \left(1 + \frac{K}{E}\right) \cdot \frac{D}{x}$$

$$D = -\frac{x}{(E + K)} \quad (32)$$

c) Two lines obtained in experiments in which the concentration of  $x$  in the original plasma differs, intercept at the point

$$\left(0, \frac{1}{E}\right)$$

d) Two lines in experiments in which  $E$  differs, intercept at the point

$$-\frac{x}{K}, -\frac{1}{h \cdot K}$$

*Proof:* when the point of interception is  $(a, b)$  then:

$$h \cdot b = a \left(1 + \frac{K}{E_1}\right) \cdot \frac{1}{x} + \frac{1}{E_1}$$

$$h \cdot b = a \left(1 + \frac{K}{E_2}\right) \cdot \frac{1}{x} + \frac{1}{E_2}$$

$$a = \frac{\frac{1}{E_2} - \frac{1}{E_1}}{\left(1 - \frac{K}{E_2}\right) \cdot \frac{1}{x} - \left(1 - \frac{K}{E_1}\right) \cdot \frac{1}{x}} = -\frac{x}{K}$$

$$h \cdot b = \frac{1}{K} + \frac{1}{E_2} - \frac{1}{E_1} = -\frac{1}{K}$$

This is an intercept in the third quadrant.

e) Assume that the point  $(D', \frac{1}{E'})$  is situated on the line described by the formula:

$$t \cdot h = \frac{1}{E} + (1 + \frac{K}{E}) \cdot \frac{D}{x}$$

then: 
$$\frac{1}{E'} = \frac{1}{E} + (\frac{E + K}{E}) \cdot \frac{D'}{x}$$

$$E = E' + (E \cdot E' + K \cdot E') \cdot \frac{D'}{x}$$

$$E - E' = (E \cdot E' + K \cdot E') \cdot \frac{D'}{x}$$

$$D' = \frac{E - E'}{E' (E + K)}$$

thus: 
$$D' = \frac{(E - E') \cdot x}{E' \cdot (E + K)} \quad (33)$$

When  $D'$  remains constant the relationship between  $E'$  and  $x$  will be:

$$\frac{1}{E'} = \frac{1}{E} + \frac{(E + K) \cdot D'}{E} \cdot \frac{1}{x} \quad (34)$$

and the relationship between  $E$  and  $x$  will be:

$$E = - E' \frac{(K \cdot D' + x)}{(E' \cdot D' - x)} \quad (35)$$

When:  $E' \cdot D' \ll x$ , this can be simplified into:

$$E = - E' \left( \frac{D' \cdot K}{x} + 1 \right) \quad (36)$$

so: 
$$\frac{E}{E'} = - \left( \frac{D' \cdot K}{x} + 1 \right) \quad (37)$$

And when: 
$$\frac{E}{E'} = \frac{1}{x}$$

$$D' = \frac{1 - x}{K} \quad (38)$$

The developments sub e) are of importance because they contain an alternative explanation for the graphical picture obtained by addition of inhibitors.

### VIII. Addition of Substrate which is not Free of Enzyme

Because it is rather difficult to get different clotting-factors separated and in a pure state, the situation that the enzyme of a reaction is added along with the substrate will be frequently encountered. In that case the amount of enzyme ( $E_D$ ) in dilution will be dependent upon the dilution ( $D$ ).

$$\text{So:} \quad t \cdot h = \frac{1}{E_D} + \left(1 + \frac{K}{E_D}\right) \cdot \frac{1}{x} \cdot D \quad (39)$$

$$\text{and:} \quad E_D = \frac{E}{D} \quad (40)$$

$$\begin{aligned} t \cdot h &= \frac{D}{E} + \frac{D}{E} \cdot \left(K + \frac{E}{D}\right) \cdot \frac{1}{x} \cdot D \\ &= D^2 \left(\frac{K}{E} \cdot \frac{1}{x} + \frac{1}{D} \cdot \left(\frac{1}{E} + \frac{1}{x}\right)\right) \end{aligned} \quad (41)$$

for  $D = 0$  is  $t = 0$ ; so the graph passes through the origin.

The graph is approximately straight when:

$$D \cdot \frac{K}{E} \cdot \frac{1}{x} \ll \frac{1}{E} + \frac{1}{x} \quad \text{or:}$$

$D \cdot K \ll x + E$ ; this is usually true because  $K$  is very small.

In that case the formula (41) is written as follows:

$$t \cdot h \approx D \left(\frac{1}{E} + \frac{1}{x}\right) \quad (42)$$

The graph is in approximation a parabola when:

$$D \cdot \frac{K}{E} \cdot \frac{1}{x} \gg \frac{1}{E} + \frac{1}{x} \quad \text{or:}$$

$$D \cdot K \gg x + E$$

In that case formula (41) becomes:

$$t \cdot h \approx \frac{K}{E} \cdot \frac{1}{x} \cdot D^2 \quad (42')$$

When  $E$  is present in both the original plasma and the reagent, it will vary with the dilution to a lesser extent.

$$E_D = E + \frac{E_x}{D} \quad (43)$$



( $E_x$  = the amount of enzyme in the original plasma;  $E$  = the amount of enzyme in the reagent.)

By substitution of (43) into (30) it follows that:

$$\begin{aligned} t \cdot h &= \frac{D}{D \cdot E + E_x} + \left(1 + \frac{D \cdot K}{D \cdot E + E_x}\right) \cdot \frac{1}{x} \cdot D \\ &= \frac{D^2 (E + K) + D (x + E_x)}{D \cdot E + E_x} \cdot \frac{1}{x} \end{aligned} \quad (44)$$

$$t \cdot h = D \cdot \frac{1}{x} \cdot \frac{D (E + K) + E_x + x}{D \cdot E + E_x} \quad (45)$$

When specific conditions are fulfilled this formula can be used in a simplified form.

$$\left. \begin{array}{l} D \cdot K \gg x \\ D \cdot E \gg E_x \end{array} \right\} \rightarrow t \cdot h = \frac{D}{x} \left( \frac{K}{E} + 1 \right) \quad (46)$$

$$\left. \begin{array}{l} D \cdot K \gg x \\ D \cdot E \ll E_x \end{array} \right\} \rightarrow t \cdot h = \frac{D}{x} + \frac{D^2 K}{x E_x} \quad (47)$$

$$\left. \begin{array}{l} D \cdot K \ll x \\ D \cdot E \gg E_x \end{array} \right\} \rightarrow t \cdot h = \frac{D}{x} + \frac{1}{E} \quad (48)$$

$$\left. \begin{array}{l} D \cdot K \ll x \\ D \cdot E \ll E_x \end{array} \right\} \rightarrow t \cdot h = \frac{D}{x} + \frac{D}{E_x} \quad (49)$$

## X. The Buffer Value

The general procedure for the estimation of a clotting-factor is addition of that clotting-factor to a mixture containing all factors but the factor to be tested in excess.

In practice it is seen that the mixture itself, without addition of the clotting-factor in which it is deficient, will clot in a certain time (buffer value) after recalcification. This can be due to either one or a combination of two phenomena.

1) The clotting-factor proceeds independently of the factor to be tested, via a pathway for which this factor is not a missing link. In that case, the clotting-velocity ( $v_t$ ) after addition of an unknown amount of the factor to be tested and recalcification will be the sum of the separate velocities along the two independent pathways.

When  $v_t$  is the velocity due to the clotting-factor added in variable amounts,  $v_b$  is the velocity due to the parallel pathway,  $t_t$  is the clotting-time found when

the variable factor is added and  $t_b$  is the clotting-time when the factor to be tested is not added, it follows that,

$$\text{as } v_t = v_f + v_b$$

$$\text{and } v_t = \frac{1}{t_t \cdot h}$$

$$\text{while } v_b = \frac{1}{t_b \cdot h}$$

$$\frac{1}{v_f} = \frac{t_t \cdot t_b}{t_b - t_t} \cdot h \quad (50)$$

The values obtained from factor VIII or factor IX estimation according to Biggs (ref. 6) seem to be an illustration of this case (Fig. 6).

2. A second possible cause of the "buffer value" is that the "reagent" contains a certain amount of substrate. In that case the buffer value will depend upon the amount of clotting-factor present in the reagent ( $S_b$ ).

$$t_b \cdot h = \frac{K + E + S_b}{E \cdot S_b} \quad ; \quad S_b = \frac{K + E}{E \cdot t_b \cdot h - 1} \quad (12) \quad (51)$$

When substrate is added in the amount  $S_x$  it follows that:

$$t_t \cdot h = \frac{K + E + (S_b + S_x)}{E (S_b + S_x)} \rightarrow S_b + S_x = \frac{K + E}{E \cdot t_t \cdot h - 1} \quad (52)$$

From (51) and (52) it follows that:

$$\frac{1}{S_x} = \frac{(t_b \cdot h \cdot E - 1) (t_t \cdot h \cdot E - 1)}{(E + K) (E \cdot h) (t_b - t_t)} \quad (53)$$

So there is no longer a linear relationship between  $\frac{1}{S_x}$  and  $t_t$ .

This formulas can be rearranged as follows:

$$\frac{t_b - t_t}{S_x} = \frac{1}{S_b} \cdot t_t - \frac{1}{S_b \cdot E \cdot h} \quad (54)$$

So  $(t_b - t_t) : S_x$  varies linearly with  $t_t$ .

It is now possible to plot  $t_t$  against  $(t_b - t_t) : S_x$  in a linear graph and deduce  $S_b$  from the slope of that graph (ref. 12). After correction for the value of  $S_b$ , which is now known, it will be possible to make a t-D graph to check the validity of the method. This is illustrated in Fig. VII. It can be imagined that the values obtained in the system shown in Figs. VI and VII can very well simulate a straight line when plotted directly on a double logarithmic scale. Although it is not claimed that this is the sole explanation of the frequently encountered

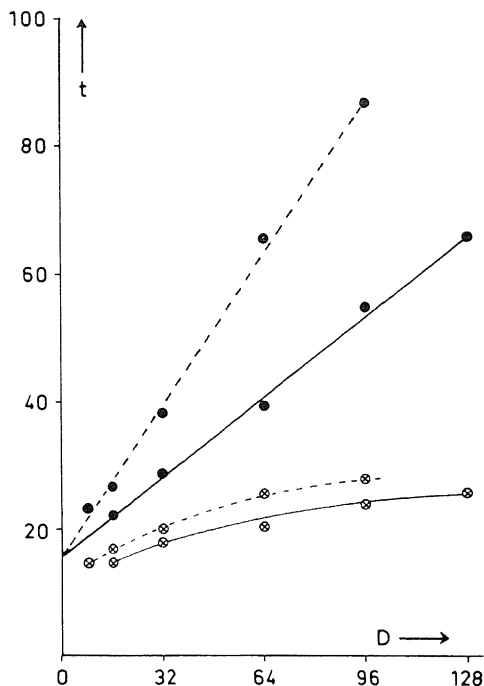

Fig. 6. *Time - dilution plot of a factor IX estimation.* For reaction procedure see: ref. 6. The data obtained in the test ( $\otimes$ ) do not fit in a straight line unless they have been corrected for the buffer value ( $\bullet$ ). In the latter case the steepness of the line obtained, again reflects the amount of factor IX present in the original plasma. Here normal plasma (—) and plasma from a known carrier of haemophilia B (---) are compared. The carrier plasma exhibiting 54% activity. It can directly be seen that the diminished activity is not due to an inhibitor, as  $t_{\min}$  is equal in both cases.

phenomenon of a straight line in a double logarithmic scale, it offers at least one explanation.

Another possible explanation is that  $t_t$  reflects the integrated form of the velocity-concentration curve, as could be the case when a series of reactions is coupled. Further theoretical and practical work on this point is in progress in our laboratory.

### Summary

Application of the methods of enzyme-kinetic analysis to the results of clotting tests is feasible and can yield useful results. However, the standard methods of enzyme kinetics are not applicable without modifications imposed by the peculiarities of the blood-clotting enzyme system. The influence of the following complicating circumstances is calculated:

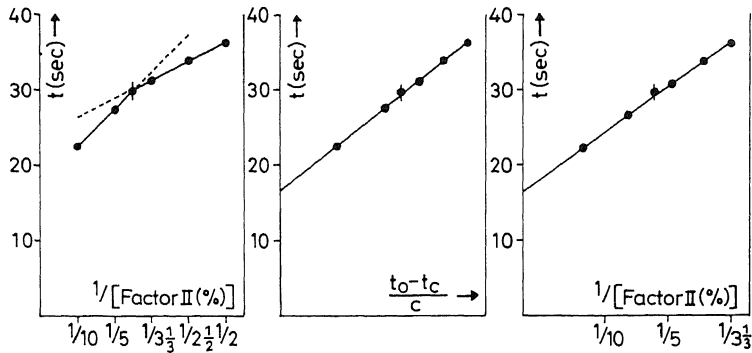

Fig. 7. The Lineweaver-Burk plot of a one stage factor II assay. The left graph shows the failure to obtain a straight line with uncorrected values, the middle graph shows the graph from which the correction value is obtained. The right graph shows the Lineweaver-Burk plot of the corrected values. The points are obtained as the mean of 60 to 300 estimations. The vertical lines in the center dots represent 4 times the standard deviation. In the outer dots, 4 times the standard deviation falls within the dot.

1. Substrate is not present in excess.
2. Only relative measures exist for concentrations of substrate or enzymes.
3. Enzymes and substrates are often added together.
4. Reagents are not pure.
5. Clotting-time is our only measure for clotting-velocity.

Formulas are deduced, which makes it possible to recognize the effect of these complications.

### Résumé

Il est possible d'appliquer les méthodes de l'analyse cinétique enzymatique aux résultats obtenus avec des tests de coagulation et d'en tirer une information valable. Néanmoins les méthodes standard de la cinétique enzymatique ne sont pas applicables sans les modifications imposées par les particularités du système enzymatique de la coagulation sanguine. On a pris en considération l'influence des conditions suivantes qui compliquent le problème.

1. Le substrat n'est pas présent en excès.
2. Il existe seulement des mesures relatives de la concentration des substrats ou enzymes.
3. Les enzymes et substrats sont souvent ajoutés ensemble.
4. Les réactifs ne sont pas purs.
5. Le temps de coagulation est notre seule mesure de la vitesse de coagulation.

De cette étude on déduit des formules qui rendent possible l'évaluation de l'effet de ces complications.

### Zusammenfassung

Die Anwendung der Methoden der enzymkinetischen Analyse auf die Ergebnisse der Blutgerinnungsteste ist möglich und kann zu nützlichen Ergebnissen führen. Die Standardmethoden der Enzymkinetik können jedoch nicht ohne Modifikationen angewendet werden, die durch die Eigenheiten des Blutgerinnungsfermentsystems verursacht werden. Der Einfluß der folgenden komplizierenden Umstände wird berechnet: 1. Das Substrat liegt nicht im Überschuß vor, 2. es gibt nur relative Messungen der Konzentrationen von Substrat oder Enzym, 3. Enzyme und Substrate werden häufig gleichzeitig zugesetzt, 4. die Reagentien sind nicht rein, 5. die Gerinnungszeit ist die einzige Maßzahl für die Bestimmung der Gerinnungsgeschwindigkeit. Es werden Formeln abgeleitet, welche es möglich machen, die Einflüsse dieser Komplikationen zu erkennen.

### References

- (1) *Reiner, M.*: Behaviour of enzyme systems. Burgess Publishing Co. Minneapolis, U. S. A., 1957.
- (2) *Dixon, M., E. Webb*: Enzymes. Longmans, Green and Co. London 1958.
- (3) Report of the International Committee for the Nomenclature of Blood Clotting Factors (1963). F. K. Schattauer, Stuttgart 1964.
- (4) Report of the Commission on Enzymes of the International Union of Biochemistry (1961). Pergamon Press, Oxford 1961.
- (5) *Lineweaver, H., D. Burk*: The determination of enzyme association constants. J. Amer. chem. Soc. 56: 658 (1934).
- (6) *Biggs, R., R. G. Macfarlane*: Human blood coagulation and its disorders. Blackwell Scientific Publications, Oxford. 3rd ed., 1962.
- (7) *Macfarlane, R. G.*: An enzyme cascade in the blood clotting mechanism, and its function as a biochemical amplifier. Nature 202: 498 (1964).
- (8) *Schnittger, H., R. Gross*: Über ein Universalgerät zur automatischen Registrierung von Gerinnungszeiten. Klin. Wschr. 32: 1011 (1954).
- (9) *Schnittger, H.*: M. D. Thesis. Marburg 1956.
- (10) *Hemker, H. C., J. J. Veltkamp, A. Hensen, E. A. Loeliger*: Proc. Gleneagles Conf., International Committee for the Nomenclature of Blood Clotting Factors. (1963) Thrombos. Diathes. haemorrh. (Stuttg.) Suppl. 13, p. 380, 1964.
- (11) *Hemker, H. C., J. J. Veltkamp, A. Hensen, E. A. Loeliger*: Nature of prothrombin biosynthesis, preprothrombinaemia in vitamin K-deficiency. Nature 200: 589 (1963).
- (12) *Hemker, H. C.*: Quantitering in de bloedstolling. Maandsch. Kindergeneesk. 22: 503 (1964).