

MATHEMATISCH CENTRUM

2e BOERHAAVESTRAAT 49

AMSTERDAM

STATISTISCHE AFDELING

Leiding: Prof. Dr D. van Dantzig

~~Chef van de Statistische Consultatie: Prof. Dr. J. Hemelrijk~~

Report S 201

Performance trial no. VII on flame radiation.

Statistical Analysis of the data.

I. The effects of the four main factors on the radiation

by

R. Doornbos

June 1956

1. The factors studied

Performance trial no. VII was carried out to examine the effect of the following factors, each at two levels, on the radiation of flames:

- A. type of fuel (oil and gas),
- B. momentum (1000 g and 1500 g),
- C. combustion air quantity (110% and 140% stoichiometric),
- D. combustion air temperature (100° C and 650° C).

The main purpose of the experiment was to study the effect of factor D (and its interactions with the factors A, B and C) on:

- R_1 , the radiation of the flame alone,
- R_2 , the radiation of the flame + the hot refractory,
- R_3 , the radiation of the hot refractory (all three in $\text{cal cm}^{-2}\text{sec}^{-1}$) and

$$e = 1 - \frac{R_2 - R_1}{R_3}, \text{ the emissivity.}$$

These effects will be analysed in this report, whereas a number of questions concerning a.o. the temperature and the amount of carbon in the flames will be discussed in a second report.

2. The observations

By varying the variables A, B, C and D we get 16 combinations, each of which gives "a flame". Each one of these 16 flames was produced on two different days and on each day observed at two different times. Moreover the observations on R_1 and R_2 were made once while the instruments were moving up and again as they were moving down along the slots in the wall of the furnace. From R_2 only the maximum values are analysed, from R_1 also the values integrated over the slots were at our disposal. The flames were observed at the slots numbered 2, 3, 4, 5, 6 and 7. In table 1.1 an example is given for flame 1 (oil, 1000 g momentum, 100% combustion air of 100° C) at slot 2, as far as the radiation is concerned.

The e values are calculated from R_1 -max (average of up- and down-reading), R_2 -max (also averaged over up and down) and R_3 .

Because it was not possible to examine the flames according to the design planned beforehand, day-effects or team-effects on the result if present are difficult to detect. Fortunately in previous experiments the team effect has been found to be rather

small. For that reason we did not take into account a day- or a team-effect in the models described in the next section.

Table 1.1
Example of the observations

| flame | slot | date | time | team | R ₁ up | inte- grated down | R ₁ up | (max) down | R ₂ up | (max) down | R ₃ | e |
|-------|------|---------|-------|------|----------------------|-------------------------|----------------------|---------------|----------------------|---------------|----------------|------|
| 1 | 2 | 27-6-55 | 14.47 | B | 6.4 | 6.25 | 7.2 | 7.1 | 8.9 | 9.1 | 6.578 | 0.72 |
| 1 | 2 | 27-6-55 | 16.44 | A | 6.2 | 5.9 | 6.9 | 6.9 | 8.6 | 8.3 | 6.578 | 0.76 |
| 1 | 2 | 28-6-55 | 19.50 | A | 6.2 | 5.3 | 7.45 | 6.9 | 8.3 | 8.2 | 6.317 | 0.83 |
| 1 | 2 | 28-6-55 | 21.10 | A | 5.5 | 5.3 | 6.35 | 6.4 | 8.8 | 8.5 | 6.508 | 0.66 |

3. The mathematical models used

First the observations at each slot are analysed separately. For R₁ (mean and maximum values) and R₂ the following model is proposed.

$$\begin{aligned}
 (3.1) \quad \underline{x}_{ijklmno} = & \mu + \mu_{i\dots} + \mu_{j\dots} + \mu_{\dots k\dots} + \mu_{\dots l\dots} + \mu_{ij\dots} + \mu_{ik\dots} \\
 & + \mu_{i\dots l\dots} + \mu_{jk\dots} + \mu_{j\dots l\dots} + \mu_{\dots kl\dots} + \mu_{ijk\dots} + \mu_{ijl\dots} \\
 & + \mu_{ikl\dots} + \mu_{jkl\dots} + \mu_{ijkl\dots} + \mu_{\dots m} + \underline{\epsilon}_{ijklm} + \\
 & + \underline{\epsilon}_{ijklno} + \underline{\epsilon}_{ijklmno}, \quad 1)
 \end{aligned}$$

where

$$(3.2) \quad \left\{ \begin{array}{l} i = 1,2 \text{ (A-effect),} \\ j = 1,2 \text{ (B-effect),} \\ k = 1,2 \text{ (C-effect),} \\ l = 1,2 \text{ (D-effect),} \\ m = 1,2 \text{ (up-down),} \\ n = 1,2 \text{ (date),} \\ o = 1,2 \text{ (time).} \end{array} \right.$$

The parameters μ with one index represent the main-effects, those with two indices the first order interactions, etc. All these effects are normalized so as to make the sum over each of the indices equal to zero:

$$\begin{aligned}
 \sum_i \mu_{i\dots} &= 0 \\
 \sum_i \mu_{ij\dots} &= \sum_j \mu_{ij\dots} = 0, \text{ etc.}
 \end{aligned}$$

1) Random variables are denoted by underlined symbols.

We suppose that $\underline{\xi}_{ijkln}$, $\underline{\xi}_{ijklno}$ and $\underline{\xi}_{ijklmno}$ respectively are completely independent and normally distributed with means zero and variances σ_b^2 , σ_w^2 and σ^2 respectively.

The validity of these assumptions has not been tested but it is known from theoretical investigations that the results of the analysis of variance, especially in the case of the so-called 2^p factorial design used here, are fairly reliable also when the assumptions are only approximately true. So the σ_b^2 , σ_w^2 and σ^2 are the variances which cause the variation respectively from day to day ("between flames") and between two times of observation ("within flames") and between two observations at almost the same time ("rest-variance"). The model (3.1) is a so-called "mixed model". A more extensive description of the applied methods and the underlying assumptions may be found for instance in MOOD (1950), Chapter 14.

The scheme of the corresponding analysis of variance is given in table 3.1 (p. 4).

Table 3.1 Analysis of variance of R_1 and R_2

| Source of Variation | degrees of freedom | Sum of squares | Expected Mean Square |
|---------------------|--------------------|---|---|
| A | 1 | $\sum_A = 64 \sum_i (\bar{x}_{i\dots\dots} - \bar{x}\dots\dots)^2$ | $64 \sum_i \mu_{i\dots\dots}^2 + 4\sigma_B^2 + 2\sigma_W^2 + \sigma^2$ |
| ⋮ | | | |
| A x B | 1 | $\sum_{AB} = 32 \sum_{i,j} (\bar{x}_{ij\dots\dots} - \bar{x}_{i\dots\dots} - \bar{x}_{.j\dots\dots} + \bar{x}\dots\dots)^2$ | $32 \sum_{i,j} \mu_{ij\dots\dots}^2 + 4\sigma_B^2 + 2\sigma_W^2 + \sigma^2$ |
| ⋮ | | | |
| A x B x C x D | 1 | $\sum_{ABCD} = 8 \sum_{i,j,k,l} (\bar{x}_{ijkl\dots} - \bar{x}_{ijk\dots} - \bar{x}_{ij.l\dots} - \bar{x}_{i.kl\dots} - \bar{x}_{.jkl\dots} + \bar{x}_{ij\dots} + \bar{x}_{i.k\dots} + \bar{x}_{i.l\dots} + \bar{x}_{.jk\dots} + \bar{x}_{.j.l\dots} + \bar{x}_{.kl\dots} - \bar{x}_{i\dots} - \bar{x}_{.j\dots} - \bar{x}_{.k\dots} - \bar{x}_{.l\dots} + \bar{x}\dots)^2$ | $8 \sum_{i,j,k,l} \mu_{ijkl\dots}^2 + 4\sigma_B^2 + 2\sigma_W^2 + \sigma^2$ |
| up-down | 1 | $\sum_u = 64 \sum_m (\bar{x}\dots m\dots - \bar{x}\dots\dots)^2$ | $64 \sum_m \mu_{\dots m}^2 + \sigma^2$ |
| between flames | 16 | $\sum_b = 4 \sum_{i,j,k,l} (\bar{x}_{ijkl.n.} - \bar{x}_{ijkl\dots})^2$ | $4\sigma_B^2 + 2\sigma_W^2 + \sigma^2$ |
| within flames | 32 | $\sum_w = \sum_{i,j,k,l,n} (\bar{x}_{ijkl.no} - \bar{x}_{ijkl.n.})^2$ | $2\sigma_W^2 + \sigma^2$ |
| remainder | 32 | $\sum = \sum_{i,j,k,l,m,n,o} (\bar{x}_{ijklmno} - \bar{x}_{ijklmn.} - \bar{x}_{ijkl.no} + \bar{x}_{ijkl.n.})^2$ | σ^2 |

A dot means that the observations have been averaged over the corresponding index (no such meaning is to be attached to the data of the unknown parameters $\mu_{i\dots}$ etc; in that case the dots only serve to indicate which factors do not influence the value of the parameter in question).

From this table follows that the factors A,B,C, D and the interactions between these factors must be tested by dividing the corresponding mean sum of squares by the mean square "between flames", whilst the up-down effect must be tested against the error term. At the same time it is seen from the table that the test-statistics for the hypotheses $\sigma_b^2 = 0$ and $\sigma_w^2 = 0$ are

$$\frac{32 \underline{S}_b}{16 \underline{S}_w} \quad \text{and} \quad \frac{32 \underline{S}_b}{32 \underline{S}} \quad \text{respectively.}$$

For R_3 no restrictions between up- and down-values can be made and in consequence only one measurement is available for every flame. The same holds for the e-values which are computed from the observed values of R_3 and the averages of the up- and down-values of R_1 and R_2 . Thus the index m can be omitted and the model takes a somewhat simpler form:

$$(3.3) \quad x_{ijklno} = \mu + \dots + \mu_{ijkl} + \xi_{ijkln} + \xi_{ijklno},$$

where the variances of ξ_{ijkln} and ξ_{ijklno} are respectively equal to σ_b^2 and σ_1^2 . The latter variance is the sum of the variances σ_w^2 and σ^2 of the previous model (3.1).

The sum of squares between flames, \underline{S}_b is in this case

$$(3.4) \quad \underline{S}_b = 2 \sum_{i,j,k,l} (\xi_{ijkln} - x_{ijkl.})^2.$$

This sum of squares has 16 degrees of freedom and the expectation is given by

$$(3.5) \quad \mathcal{E} \underline{S}_b = 16(2\sigma_b^2 + \sigma_1^2)$$

The effects A, B, C and D and their interactions have to be tested against \underline{S}_b . The variance between flames is tested against the error-term

$$(3.6) \quad \underline{S} = \sum_{i,j,k,l,n} (x_{ijklno} - x_{ijkln.})^2,$$

which has 32 degrees of freedom.

The analysis described so far has one drawback, namely the dependence of the results for the different slots, as the random terms $\underline{\xi}_{ijkln}$, and $\underline{\xi}_{ijklno}$ in the model (3.1) are the same for all slots. In other words: when a flame gives a high radiation in consequence of a factor not under control, the radiation is high at all slots. The model (3.3) shows the same picture as far as $\underline{\xi}_{ijkln}$ is concerned, but $\underline{\xi}_{ijklno}$ is the sum of the variation of the flame (variance σ_w^2), which is the same for all slots, and the error of observing (variance σ^2), which we may assume independent for the different slots.

For that reason another analysis has been applied according to a general mathematical model for all the slots together. For R_1 and R_2 this model reads as follows

$$(3.7) \quad \underline{x}_{sijklmno} = \mu + \mu_{s\dots} + \mu_{i\dots} + \mu_{j\dots} + \mu_{\dots k\dots} + \mu_{\dots l\dots} \\ + \mu_{\dots m} + \mu_{si\dots} + \mu_{s.j\dots} + \dots + \mu_{\dots kl} \\ + \mu_{sij\dots} + \dots + \mu_{.jkl} + \mu_{sijk\dots} + \dots + \mu_{.ijkl} \\ + \mu_{sijkl} + \mu_{\dots m} + \underline{\xi}_{ijkln} + \underline{\xi}_{ijklno} + \underline{\xi}_{sijklmno}$$

where the random terms $\underline{\xi}$ are all normally distributed, independent one from another, with mean values 0 and variances σ_b^2 , σ_w^2 and σ^2 respectively. The suffix s runs through the numbers 2, ..., 7, according to the six slots. Because the existence of the up-down effect and the presence of the variance within flames can be demonstrated clearly by means of the analysis of the separate slots, the further analysis has not been based on the observations $\underline{x}_{sijklmno}$, but on the averages

$$(3.8) \quad \underline{x}_{sijkln} = \frac{1}{4} \sum_{m,o} \underline{x}_{sijklmno}$$

For the averages the model (3.7) reduces to:

$$(3.9) \quad \underline{x}_{sijkln} = \mu + \mu_{s\dots} + \mu_{i\dots} + \mu_{j\dots} + \mu_{\dots k} \\ + \mu_{\dots l} + \mu_{si\dots} + \dots + \mu_{\dots kl} \\ + \mu_{sij\dots} + \dots + \mu_{.jkl} \\ + \mu_{sijk} + \dots + \mu_{.ijkl} + \mu_{sijkl} \\ + \underline{I}_{ijkln} + \underline{\Pi}_{sijkln}$$

where

$$\underline{I}_{ijkln} = \underline{\xi}_{ijkln} + \underline{\xi}_{ijklno} \quad (\text{variance } \sigma_b^2 + \frac{1}{2} \sigma_w^2)$$

and

$$\underline{\Pi}_{sijkln} = \underline{\xi}_{sijkln} \quad (\text{variance} = \frac{1}{4} \sigma^2),$$

The corresponding scheme of the analysis of variance is given in table 3.2.

Table 3.2 Analysis of variance of R_1 and R_3 , all slots together

| Source of variation | degrees of freedom | Sum of squares | Expected mean square |
|---------------------|--------------------|---|---|
| S (slots) | 5 | $S_S = 128 \sum_s (\bar{x}_{s\dots\dots} - \bar{x}\dots\dots)^2$ | $\frac{128}{5} \sum_s \mu_{s\dots\dots}^2 + \sigma^2$ |
| A | 1 | $S_A = 384 \sum_i (\bar{x}_{i\dots\dots} - \bar{x}\dots\dots)^2$ | $384 \sum_i \mu_{i\dots\dots}^2 + 24\sigma_b^2 + 12\sigma_w^2 + \sigma^2$ |
| ⋮ | | | |
| A × B × C × D | 1 | $S_{ABCD} = 48 \sum_{i,j,k,l} (x_{ijkl} - x_{ijk\dots} - \dots + \bar{x}\dots\dots)^2$ | $48 \sum_{i,j,k,l} \mu_{ijkl}^2 + 24\sigma_b^2 + 12\sigma_w^2 + \sigma^2$ |
| S × A | 5 | $S_{SA} = 64 \sum_{s,i} (\bar{x}_{si\dots\dots} - \bar{x}_{s\dots\dots} - \bar{x}_{i\dots\dots} + \bar{x}\dots\dots)^2$ | $\frac{64}{5} \sum_{s,i} \mu_{si\dots\dots}^2 + \sigma^2$ |
| ⋮ | | | |
| S × A × B × C × D | 5 | $S_{SABCD} = 8 \sum_{s,i,j,k,l} (\bar{x}_{sijkl} - \bar{x}\dots\dots)^2$ | $\frac{8}{5} \sum_{s,i,j,k,l} \mu_{sijkl}^2 + \sigma^2$ |
| between flames | 16 | $S_b = 24 \sum_{i,j,k,l,m} (\bar{x}_{ijklm} - \bar{x}_{ijkl})^2$ | $24\sigma_b^2 + 12\sigma_w^2 + \sigma^2$ |
| remainder | 80 | $S = 4 \sum_{i,j,k,l} (\bar{x}_{sijklm} - \bar{x}_{scijkl} - \bar{x}_{cijklm} + \bar{x}_{cijkl})^2$ | σ^2 |

So all the effects in which the slots are involved have to be tested against the remainder term, the other effects against the sum between flames.

For R_3 and e we get the same table for the analysis, now based on the averages of the two observations on each flame instead of on the averages of 4 observations. Operating the averaged values (3.8) results in a remainder term with 80 degrees of freedom instead of 352. The power of the tests is however only slightly diminished by this procedure (cf E.S. PEARSON and H.O. HARTLEY (1951) where charts of the power-functions of the analysis of variance test are given).

4. The results

In tables 4.1, 4.2, 4.3, 4.4 and 4.5 the results of the analysis are given. The figures give the estimated effects of the low level of the independent variable (oil, low momentum, 110% stoichiometric air, 100° C), as far as the main effects are concerned: $\mu_{1\dots}$, $\mu_{.1\dots}$ etc. If we denote the low levels of the factors with a + sign and the high levels with a -sign, all interactions get also allocated a + or -sign by multiplication of the signs of the factors involved. The effects tabulated are those which have a + sign attached to it (such as $\mu_{11\dots}$, $\mu_{22\dots}$, $\mu_{12\dots}$ etc). The effects have only been given for the slots separately and for those effects which show significant results. The roman figures denote the levels of significance as follows: I. probability of 0.05 to greater than 0.01, II. probability of 0.01 to greater than 0.001, III. probability of 0.001 or less.

Table 4.1 Results of the analysis of R_1 , maximum values.

| Slots effects | model (3.1) | | | | | | model (3.9) | |
|------------------|-------------|-----------|-----------|-----------|-----------|-----------|-------------|----------------------------|
| | 2 | 3 | 4 | 5 | 6 | 7 | Total | Interactions with slots |
| A | +2.74 III | +3.79 III | +2.45 III | +1.04 III | +0.14 | -0.14 | III | III |
| B | +0.10 | +0.39 II | +0.57 III | +0.53 III | +0.20 | +0.07 | III | III |
| C | -0.13 | +0.12 | +0.52 III | +0.78 III | +0.71 III | +0.51 III | III | III |
| D | -.88 III | -0.81 III | -0.68 III | -0.60 III | -0.53 III | -0.57 III | III | I |
| AB | +0.10 | +0.40 II | +0.62 III | +0.44 II | +0.02 | -0.03 | II | III |
| AC | -0.22 II | -0.15 | +0.31 I | +0.50 III | +0.37 II | +0.16 | | III |
| AD | -0.41 III | -0.43 II | -0.31 I | -0.31 I | -0.15 | -0.08 | II | I |
| BC | | | | | | | | |
| BD | | | | | | | | |
| CD | | | | | | | | |
| ... | | | | | | | | |
| up-effect | +0.05 III | +0.01 | +0.05 III | +0.08 III | +0.04 II | +0.03 III | | |
| ... | | | | | | | | |
| | 0.38 III | 0.64 III | 0.63 III | 0.63 III | 0.50 III | 0.35 II | | |
| | 0.20 III | 0.32 III | 0.33 III | 0.40 III | 0.28 III | 0.34 III | | |
| | 0.15 | 0.14 | 0.08 | 0.14 | 0.14 | 0.08 | | |
| total mean | 5.37 | 7.32 | 5.91 | 4.78 | 4.04 | 3.78 | | |

Table 4.2 Results of the analysis of R_1 , integrated values.

| Slots effects | 2 | 3 | 4 | 5 | 6 | 7 | Total | Interactions with slots |
|------------------|-----------|-----------|-----------|-----------|-----------|-----------|-------|----------------------------|
| A | +2.01 III | +2.60 III | +1.21 III | +0.46 III | +0.12 | -0.10 | III | III |
| B | +0.04 | +0.36 I | +0.31 I | +0.29 II | +0.12 | -0.02 | II | II |
| C | -0.02 | +0.21 | +0.42 II | +0.43 III | +0.28 III | +0.37 III | III | III |
| D | -0.64 III | -0.51 II | -0.41 II | -0.39 III | -0.25 II | -0.40 III | III | I |
| AB | +0.01 | +0.42 II | +0.41 II | +0.23 I | +0.06 | -0.14 I | I | III |
| AC | | | | | | | | I |
| AD | -0.22 I | -0.28 I | -0.26 I | -0.12 | +0.12 | +0.07 | | III |
| BC | | | | | | | | |
| BD | | | | | | | | |
| CD | | | | | -0.21 II | | | |
| ... | | | | | | | | |
| ACD | | | | | -0.23 II | | | |
| ... | | | | | | | | |
| ABCD | | | -0.24 I | | | | | |
| ... | | | | | | | | |
| up-effect | +0.06 III | +0.03 I | +0.06 III | +0.09 III | +0.03 II | +0.07 III | | |
| ... | | | | | | | | |
| | 0.40 III | 0.72 III | 0.61 III | 0.36 I | 0.36 III | 0.35 II | | |
| | 0.24 III | 0.17 I | 0.25 III | 0.44 III | 0.18 III | 0.21 III | | |
| | 0.15 | 0.19 | 0.13 | 0.20 | 0.10 | 0.10 | | |
| total mean | 4.59 | 5.79 | 4.45 | 3.66 | 3.19 | 3.28 | | |

Table 4.3 Results of the analysis of R_2 , maximum values.

| Slots effects | 2 | 3 | 4 | 5 | 6 | 7 | Total | Interactions with slots |
|------------------|-----------|-----------|-----------|-----------|-----------|-----------|-------|----------------------------|
| A | +1.30 III | +1.90 III | +0.99 III | +0.09 | -0.47 II | -0.64 III | III | III |
| B | +0.11 | +0.15 | +0.28 I | +0.33 II | +0.31 I | +0.09 | I | II |
| C | +0.12 | +0.23 I | +0.49 III | +0.86 III | +0.90 III | +0.82 III | III | III |
| D | -1.48 III | -1.41 III | -1.40 III | -1.48 III | -1.44 III | -1.53 III | III | |
| AB | | | | | | | | III |
| AC | -0.32 II | -0.33 II | -0.09 | +0.10 | +0.08 | +0.00 | | III |
| AD | | | | | | | | |
| BC | | | | | | | | |
| BD | | | | | | | | |
| CD | | | | | | | | |
| ... | | | | | | | | |
| up-effect | +0.04 I | +0.06 III | +0.06 III | +0.11 III | +0.04 III | +0.02 III | | |
| ... | | | | | | | | |
| | 0.45 III | 0.44 III | 0.60 III | 0.50 III | 0.71 III | 0.48 III | | |
| | 0.22 III | 0.25 III | 0.30 III | 0.28 III | 0.25 III | 0.26 III | | |
| | 0.17 | 0.16 | 0.08 | 0.10 | 0.11 | 0.07 | | |
| total mean | 8.82 | 10.75 | 10.29 | 9.93 | 10.17 | 9.95 | | |

Table 4.4 Results of the analysis of R_3 , mean values.

| Slots effects | model (3.3) | | | | | | model (3.9) | |
|------------------|-------------|-----------|-----------|-----------|-----------|-----------|-------------|----------------------------|
| | 2 | 3 | 4 | 5 | 6 | 7 | Total | Interactions with slots |
| A | +0.06 | +0.08 | -0.01 | -0.25 I | -0.49 III | -0.58 III | | III |
| B | | | | | | | | |
| C | +0.40 III | +0.43 III | +0.58 III | +0.72 III | +0.76 III | +0.79 III | III | III |
| D | -1.20 III | -1.29 III | -1.35 III | -1.37 III | -1.37 III | -1.36 III | III | III |
| AB | | | | | | | | |
| AC | | | | | | | | |
| AD | | | | | | | | |
| BC | | | | | | | | |
| CD | | | | | | | | I |
| ... | | | | | | | | |
| | 0.48 III | 0.47 III | 0.55 III | 0.56 III | 0.54 III | 0.57 III | | |
| | 0.19 | 0.25 | 0.22 | 0.19 | 0.28 | 0.24 | | |
| total mean | 7.36 | 8.00 | 8.68 | 9.19 | 9.71 | 9.96 | | |

Table 4.5 Results of the analysis of e, the emissivity.

| Slots effects | 2 | 3 | 4 | 5 | 6 | 7 | Total | Interactions with slots |
|---------------|------------|------------|------------|------------|------------|-----------|-------|-------------------------|
| A | +0.198 III | +0.241 III | +0.165 III | +0.084 III | +0.028 II | +0.011 | III | III |
| B | +0.008 | +0.037 III | +0.042 III | +0.037 I | -0.006 | +0.003 | II | III |
| C | -0.006 | +0.014 | +0.040 II | +0.037 I | +0.034 III | +0.018 | II | III |
| D | | | | | | | | |
| AB | +0.008 | +0.035 III | +0.044 III | +0.027 I | +0.007 | +0.001 | II | III |
| AC | -0.003 | +0.002 | +0.030 II | +0.035 I | +0.021 I | +0.014 | I | II |
| AD | | | | | | | | |
| BC | | | | | | | | |
| BD | | | | | | | | |
| CD | | | | | | | | |
| ... | | | | | | | | |
| | 0.020 | 0.041 III | 0.054 III | 0.070 III | 0.032 I | 0.064 III | | |
| | 0.036 | 0.036 | 0.023 | 0.033 | 0.038 | 0.016 | | |
| total mean | 0.529 | 0.567 | 0.491 | 0.439 | 0.374 | 0.380 | | |

5. Conclusions derived from the tables 4.1 - 4.5

Considering first the tables 4.1 and 4.2 we see that the results of the maximum and the integrated values of R_1 are nearly the same. It is seen that the oil flames give more radiation than the gas flames, mainly in the first part of the furnace. The effects of the B-effect (momentum) and the AxB interaction are approximately equal. This means that this effects more radiation with a low momentum at the slots 3,4 and 5 is only present with the oil flames. There it is the sum of the B and the AB effect. With gas flames we have to give the AB effect a minus sign and no effect is left. The C effect on the maximum radiation is most pronounced with oil flames as can be seen from the C and AC effects. At the chimney-end of the furnace an increase in the amount of combustion air causes a decreasing radiation. An increase in the air temperature gives an increase in the radiation at all slots. At the burner end of the furnace the increase is greater with oil flames than with gas flames.

A slight up- and down-effect has been found in this sense that the up-readings are systematicalley higher than the down-readings to the amount of about $2 \times 0.05 \text{ cal cm}^{-2} \text{ sec}^{-1}$. (An effect of a units at the + level means that the effect at the - level is $-a$, so the difference between the two levels is $2a$). The variations between flames and within flames are highly significant at all slots.

Some explanation may be given finally at the column headed "Interactions with slots". A significant interaction in this column means that the effect under consideration is not the same for all slots. In table 4.1 and 4.2 it can be seen that the interaction of the D-effect with the slots is not as high as the interactions with the other effects. This means, as can also be seen from the estimated effects that the influence of the air temperature is rather constant along the furnace.

Passing to table 4.3 we see that hardly any interaction between the factors is present. Only the interaction AC is significant at the slots 2 and 3, so that the radiation of the flame + the hot background is increased at the burner end with oil flames and decreased with gas flames when the amount of combustion air is increased. From slot 4 on both oil flames and gas flames show the highest radiation with the least amount of air. Further the oil flames give the highest radiation at the first slots and the gas flames at the last slots. The radiation is slightly larger with low momentum than with high

momentum at the slots 4,5 and 6. The increase of the radiation corresponding to the increase in air temperature is remarkably constant over the slots. Consequently no significant interaction SxD has been found.

Again a small up-effect has been detected and the variations between flames and within flames are again highly significant.

The effects of the factors A,B,C and D on the wall radiation R_3 (Table 4.4) are rather simple. No interactions are found. At the far end of the furnace the gas flames give the higher radiation. The momentum is of no importance and the last amount of combustion air and the highest temperature cause hotter walls at all slots.

As before a significant variation between flames is present.

Table 4.5 shows that the effects on e of the factors B and C and the interactions AB and AC are almost exactly the same. This means that the factors B and C are active only with the oil flames. The temperature of the air gives no effect, either with oil flames, nor with gas flames.

The variation between flames is again highly significant.

6. Gas and oil flames considered separately

In the preceding sections it is seen that in all cases where significant interactions occur factor A (oil-gas) is concerned. This means that oil flames and gas flames behave differently with respect to changes in momentum, amount of combustion air and air temperature.

For this reason it seems worthwhile to present the results of the analysis of the oil flames and the gas flames separately in order to obtain a simpler picture of the effects of the factors B,C and D.

These results may be found in the tables 6.1 - 6.5 and in the figures 6.1 - 6.13.

The analysis is applied to the average values on each day, thus for each slot we have a 2^3 factorial design with two replications for the oil as well as for the gas flames. Because hardly any higher order interactions were found to be present in the case where oil and gas flames were combined, we now computed only the test statistics for the main factors.

Of course the estimated effects of the factors B,C and D could have been found also from the tables in section 4 by adding the effect of the factor in consideration and its

interaction with factor A. But the separate analyses have been carried out to find out whether these effects are significant or not. The slots have been treated separately. Comparing the results with the conclusions stated in section 5 we see that these conclusions are affirmed.

Table 6.1 Analysis of R_1 , maximum values Oil- and gas-flames separately.

| Oil - Slot effect | 2 | 3 | 4 | 5 | 6 | 7 |
|-------------------|-----------|-----------|-----------|-----------|-----------|-----------|
| B | +0.20 | +0.79 II | +1.19 III | +0.97 II | +0.22 | +0.05 |
| C | -0.35 | -0.04 | +0.83 II | +1.28 III | +1.08 III | +0.67 II |
| L | -1.30 III | -1.24 III | -0.99 II | -0.91 II | -0.68 II | -0.55 I |
| total mean | 8.11 | 11.11 | 8.36 | 5.81 | 4.18 | 3.64 |
| Gas | 0 | -0.02 | -0.05 | +0.09 | +0.18 | +0.10 |
| B | +0.09 | +0.27 I | +0.22 II | +0.28 II | +0.34 II | +0.36 III |
| C | -0.47 III | -0.39 II | -0.38 III | -0.29 II | -0.38 III | -0.50 III |
| total mean | 2.63 | 3.53 | 3.46 | 3.74 | 3.90 | 3.92 |

Table 6.2 Analysis of R_1 , integrated values. Oil- and gas-flames separately.

| Oil | Slot | 2 | 3 | 4 | 5 | 6 | 7 |
|-----|------------|-----------|----------|-----------|----------|-----------|-----------|
| | effect | | | | | | |
| Oil | B | +0.04 | +0.79 II | +0.71 III | +0.52 I | +0.18 | -0.16 |
| | C | -0.15 | +0.21 | +0.70 II | +0.56 I | +0.26 | +0.38 |
| | D | -0.86 III | -0.79 II | -0.67 II | -0.50 | -0.13 | -0.17 |
| | total mean | 6.65 | 8.39 | 5.65 | 4.12 | 3.31 | 3.17 |
| gas | B | +0.03 | -0.06 | -0.10 | +0.06 | +0.05 | +0.12 |
| | C | +0.11 | +0.21 | +0.14 | +0.31 II | +0.30 III | +0.36 III |
| | D | -0.43 III | -0.23 | -0.15 | -0.27 II | -0.37 III | -0.48 III |
| | total mean | 2.53 | 3.19 | 3.23 | 3.19 | 3.07 | 3.38 |

Table 6.3 Analysis of R_2 , maximum values Oil- and gas-flames separately.

| <u>Oil</u> | Slot effects | 2 | 3 | 4 | 5 | 6 | 7 |
|------------|-----------------|-----------|-----------|-----------|-----------|-----------|-----------|
| | B | +0.12 | +0.22 | +0.49 I | +0.47 II | +0.12 | +0.01 |
| | C | -0.21 I | -0.09 | +0.39 | +0.96 III | +0.98 III | +0.82 III |
| | D | -1.64 III | -1.52 III | -1.46 III | -1.60 III | -1.48 III | -1.56 III |
| | total mean | 10.13 | 12.64 | 11.28 | 10.02 | 9.70 | 9.31 |
| <u>gas</u> | B | +0.10 | +0.07 | +0.08 | +0.19 | +0.50 I | +0.17 |
| | C | +0.44 I | +0.56 II | +0.58 II | +0.76 III | +0.81 II | +0.82 III |
| | D | -1.31 III | -1.29 III | -1.34 III | -1.35 III | -1.40 III | -1.49 III |
| | total mean | 7.52 | 8.85 | 9.31 | 9.85 | 10.64 | 10.59 |

Table 6.4 Analysis of R₃ Oil- and gas-flames separately.

| Oil | Slot | 2 | 3 | 4 | 5 | 6 | 7 |
|-----|------------|-----------|-----------|-----------|-----------|-----------|-----------|
| | effect | | | | | | |
| | B | +0.08 | +0.07 | +0.12 | +0.10 | +0.02 | -0.00 |
| | C | +0.28 I | +0.33 II | +0.48 II | +0.63 III | +0.69 III | +0.73 III |
| | D | -1.29 III | -1.38 III | -1.44 III | -1.49 III | -1.48 III | -1.47 III |
| | total mean | 7.42 | 8.08 | 8.66 | 8.94 | 9.22 | 9.38 |
| Gas | B | +0.13 | +0.17 | +0.17 | +0.20 | +0.15 | +0.15 |
| | C | +0.52 II | +0.53 II | +0.68 II | +0.80 III | +0.84 III | +0.86 III |
| | D | -1.11 III | -1.20 III | -1.26 III | -1.24 III | -1.27 III | -1.25 III |
| | total mean | 7.30 | 7.91 | 8.69 | 9.44 | 10.20 | 10.55 |

Table 6.5. Analysis emissivity e Oil- and gas-flames separately.

| Slot effect | 2 | 3 | 4 | 5 | 6 | 7 |
|-------------|--------|------------|------------|----------|-----------|--------|
| <u>Oil</u> | | | | | | |
| B | +0.014 | +0.072 III | +0.087 III | +0.064 I | +0.001 | +0.003 |
| C | -0.009 | +0.016 | +0.070 II | +0.072 I | +0.055 II | +0.032 |
| D | -0.002 | +0.002 | -0.001 | -0.006 | -0.009 | 0.000 |
| total mean | 0.727 | 0.808 | 0.656 | 0.523 | 0.402 | 0.391 |
| <u>Gas</u> | | | | | | |
| B | -0.002 | +0.002 | -0.003 | +0.009 | -0.014 | +0.002 |
| C | -0.003 | +0.012 | +0.010 | +0.002 | +0.013 | +0.005 |
| D | +0.012 | +0.014 | +0.012 | +0.032 | +0.018 | +0.015 |
| total mean | 0.332 | 0.326 | 0.325 | 0.355 | 0.346 | 0.368 |

References

A.M. MOOD (1950), Introduction to the theory of Statistics, New York, Toronto, London.

E.S. PEARSON and K.O. HARTLEY (1951), Charts of the powerfunction for analysis of variance tests, derived from the non-central F-distribution, Biometrika, 38, 112-130.

Fig 6.1

R_1, \max
oil

x low momentum
o high "

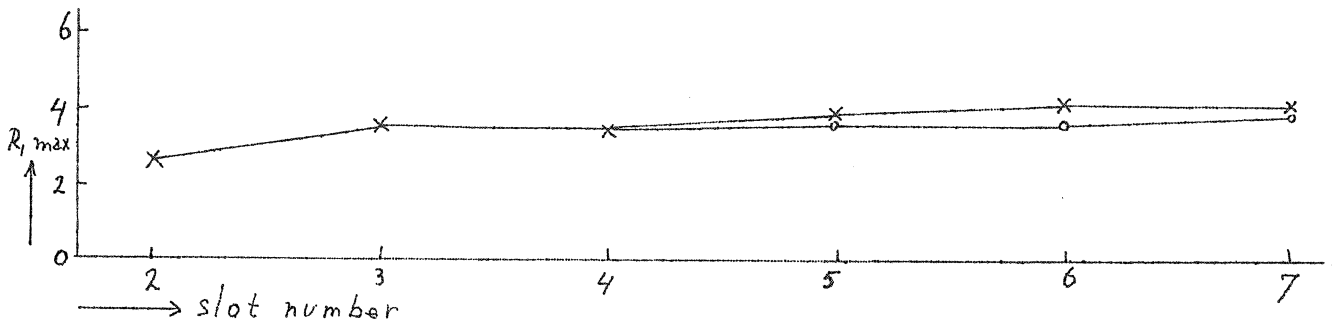
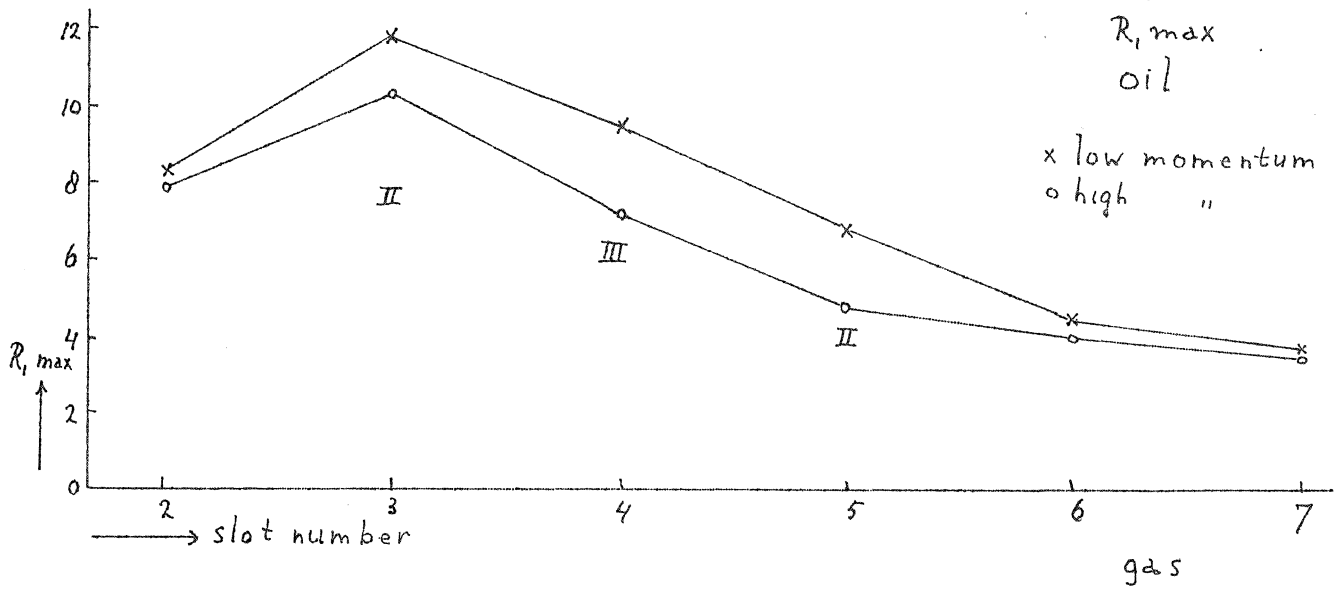

Fig 6.2

R_1, \max
oil

x 110% stoichiometric
o 140% "

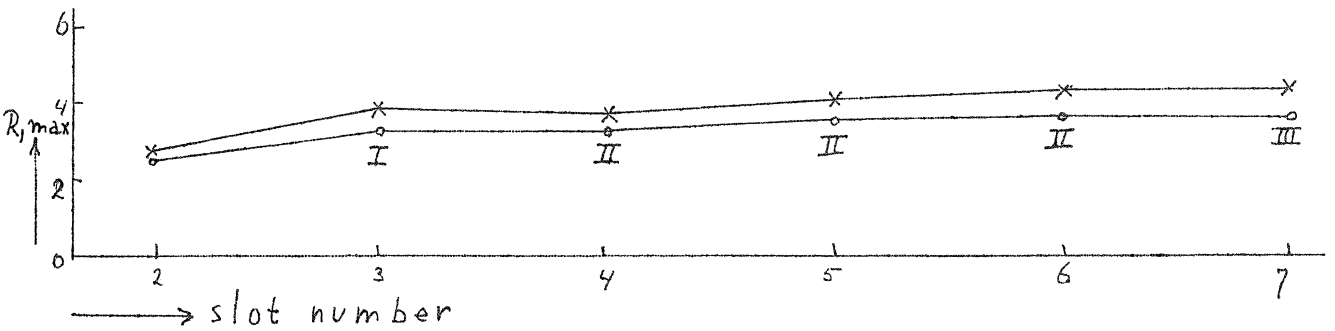
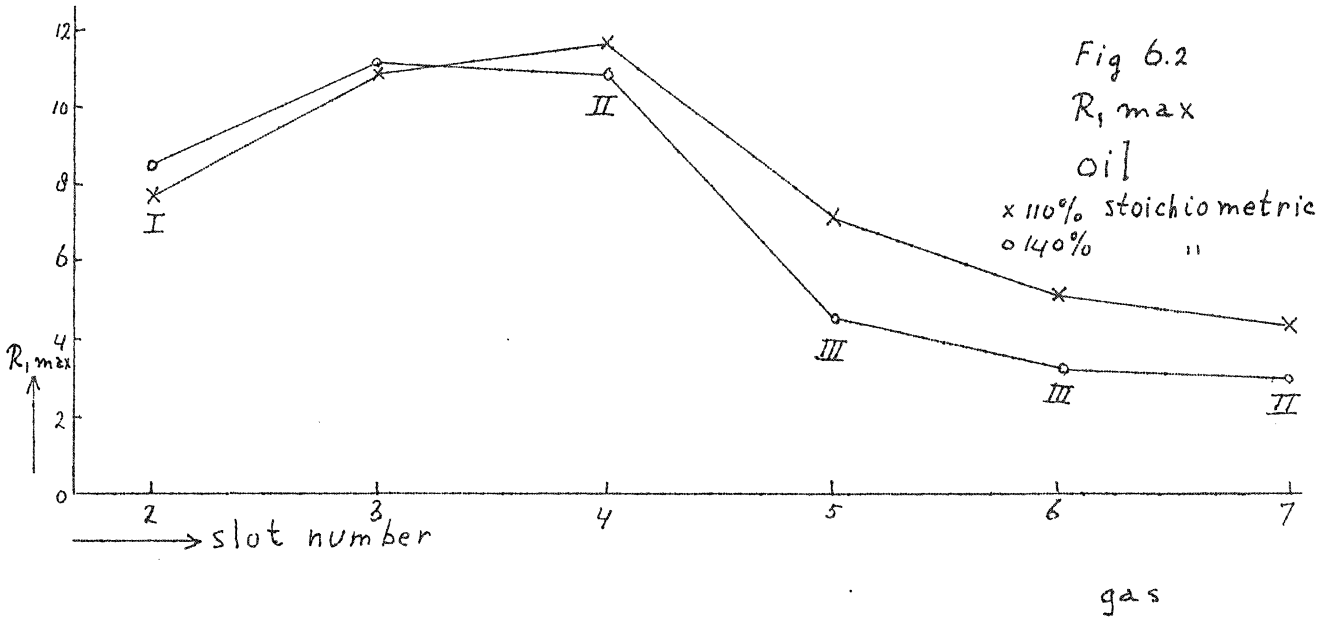

Fig 6.3

R_i, max
oil

x 100°C
o 650°C

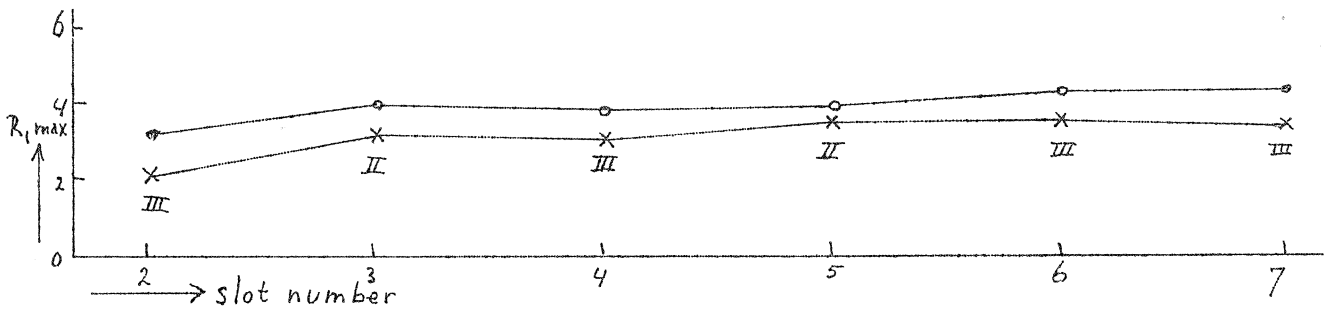
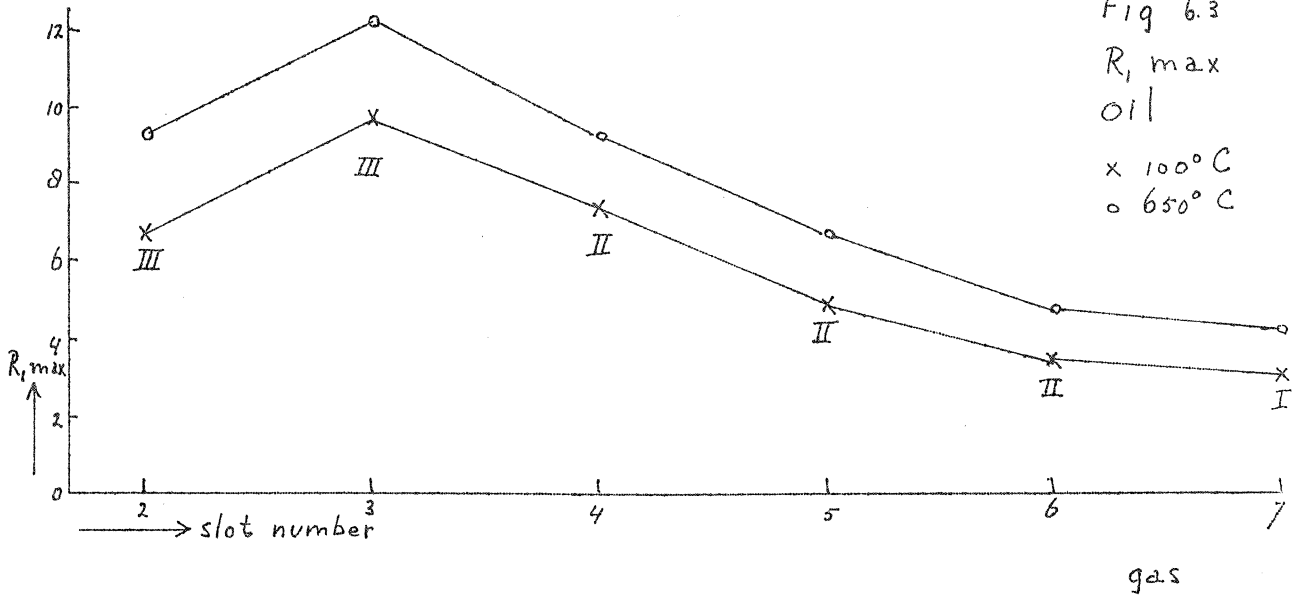
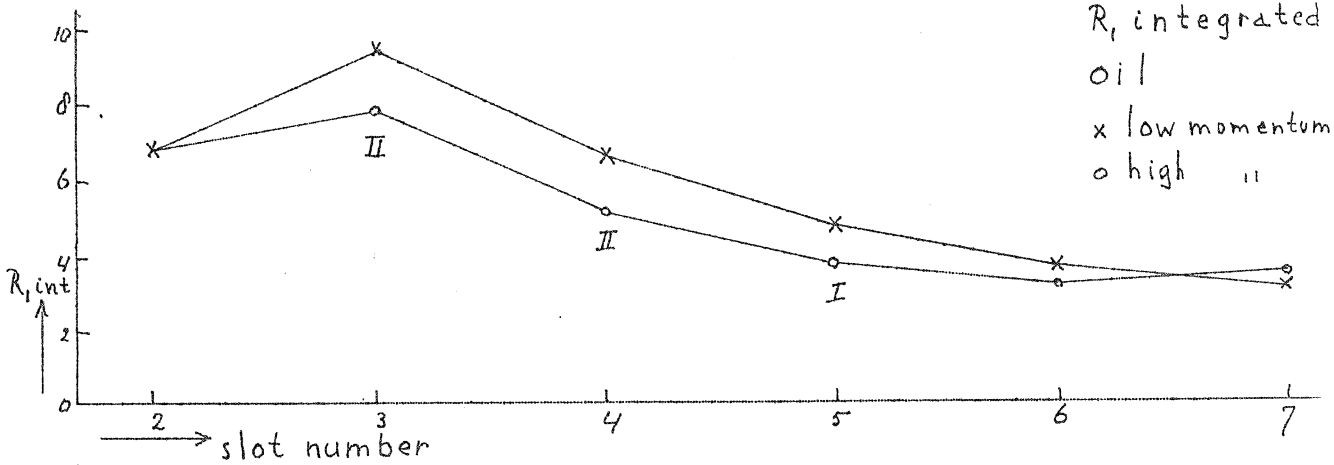

Fig 6.4

$R_i, \text{integrated}$
oil

x low momentum
o high "



gas

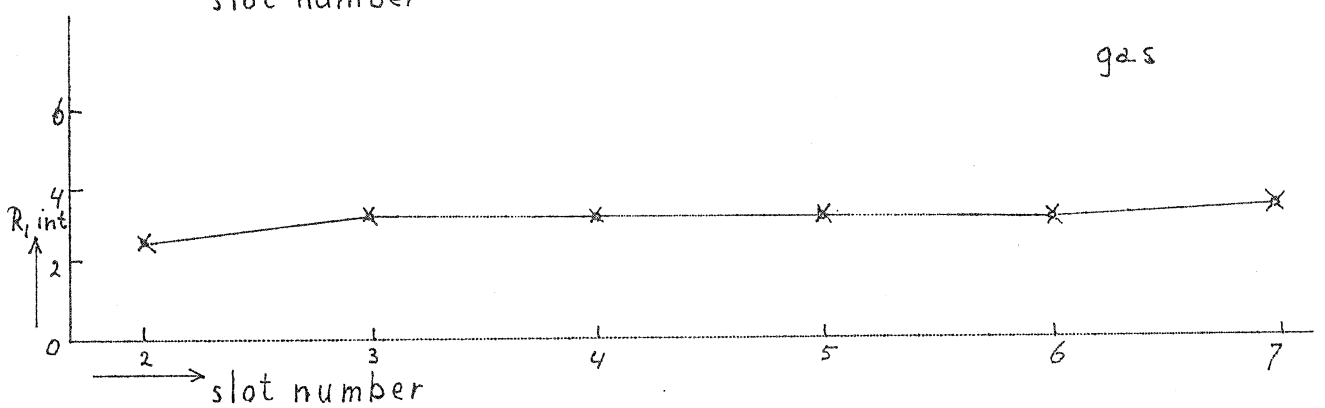

Fig 6.5
 R_i integrated
oil
x 110% stoichiometri.
o 140% "

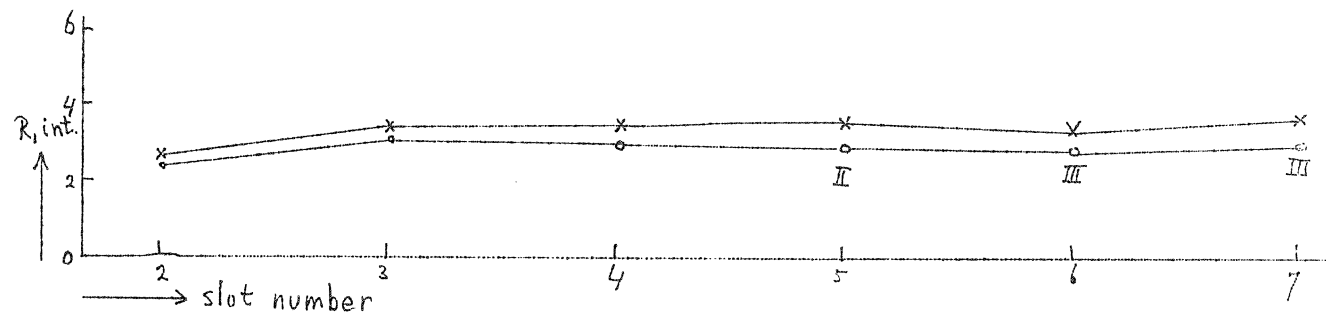
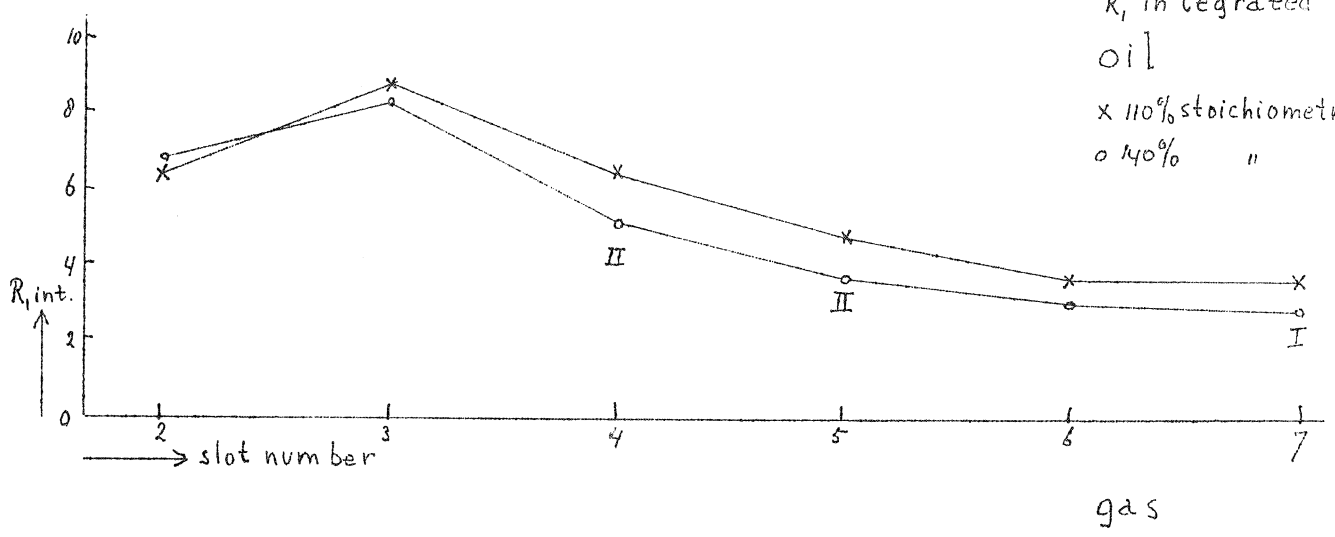
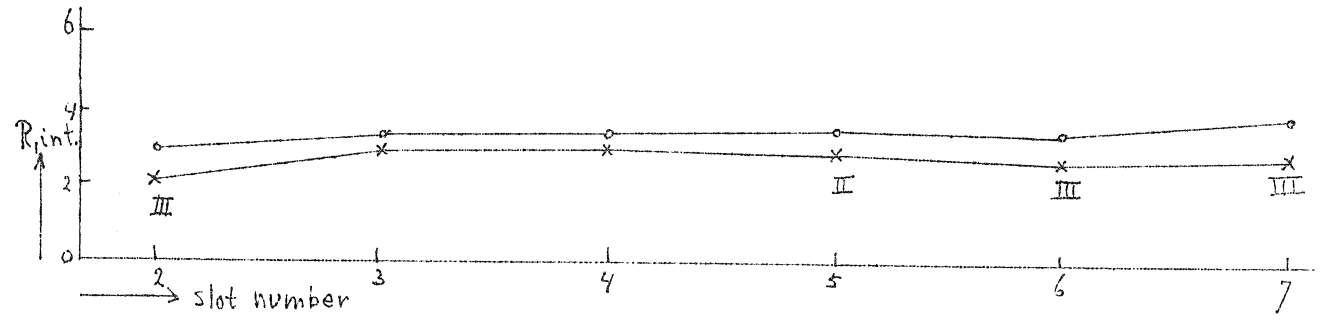
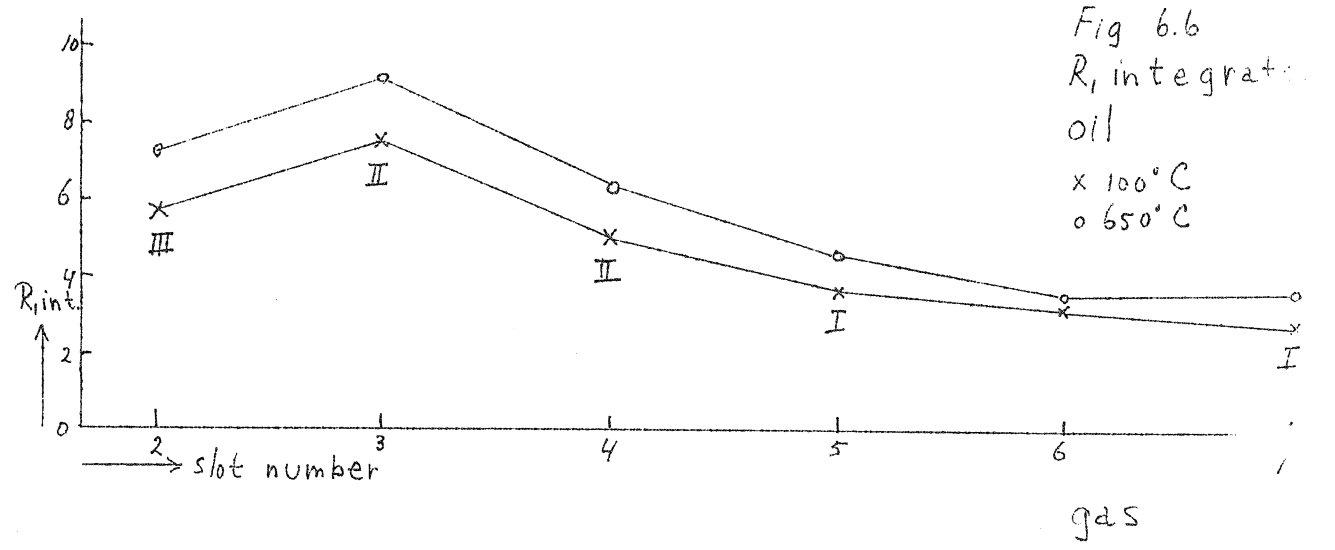

Fig 6.6
 R_i integrated
oil
x 100°C
o 650°C



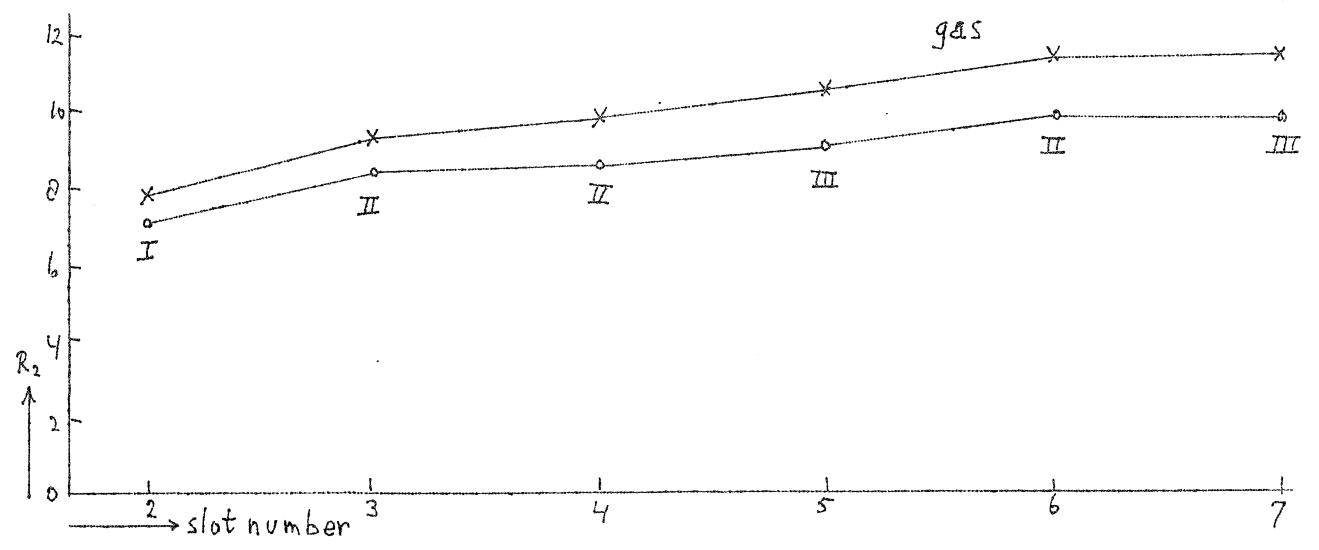
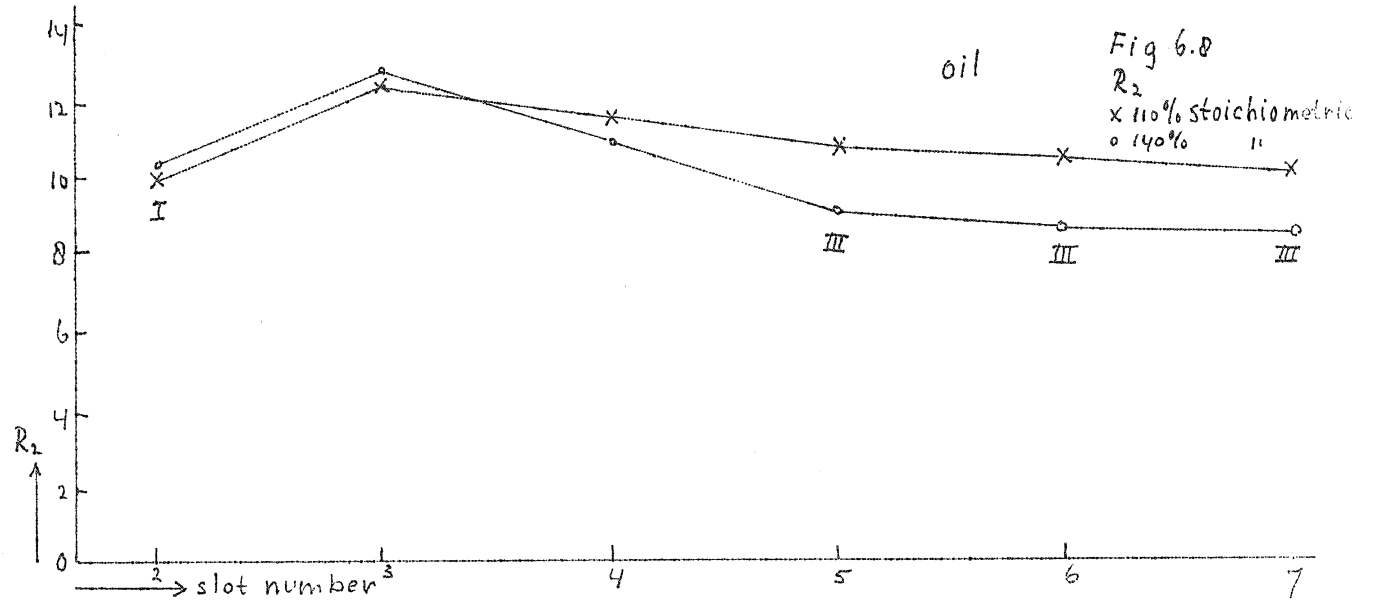
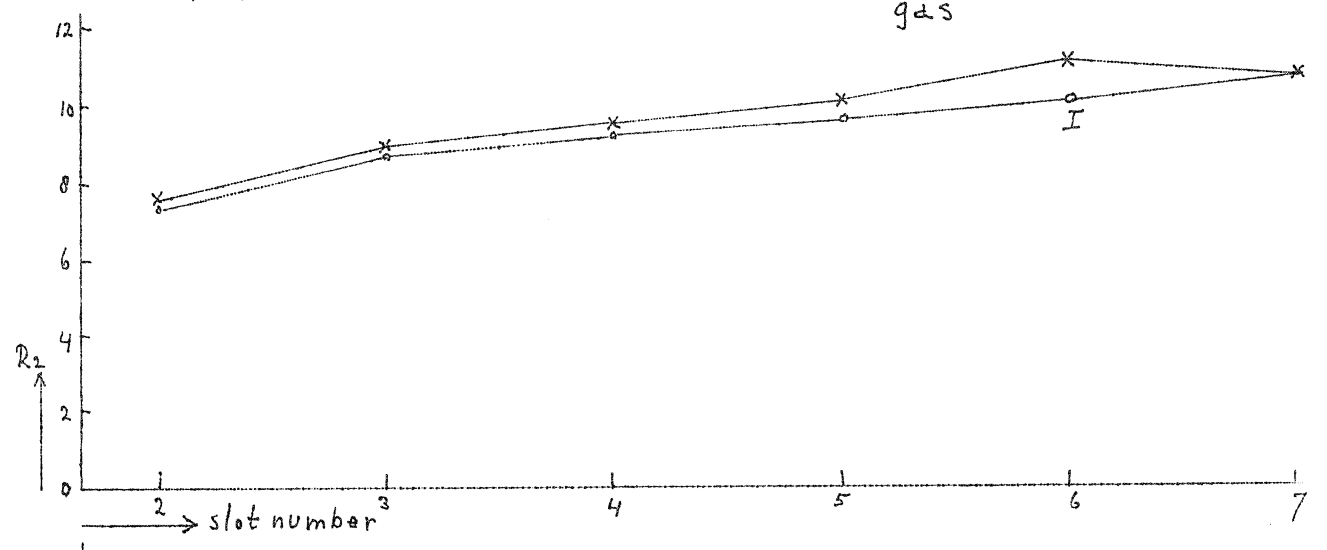
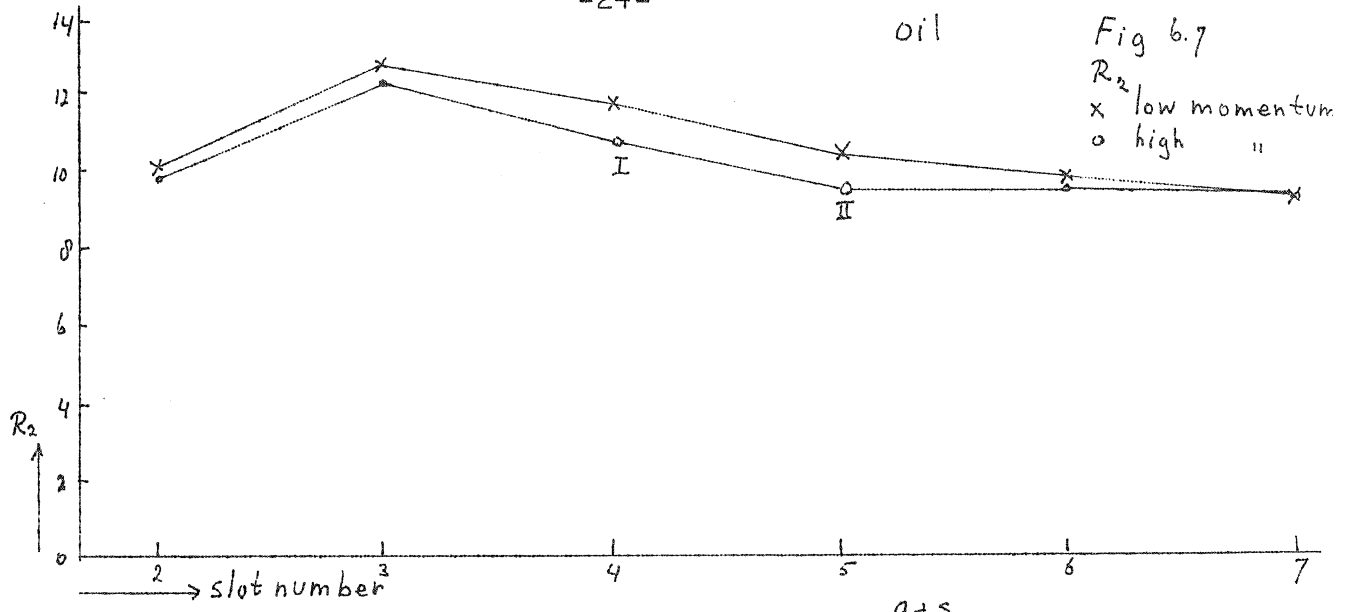
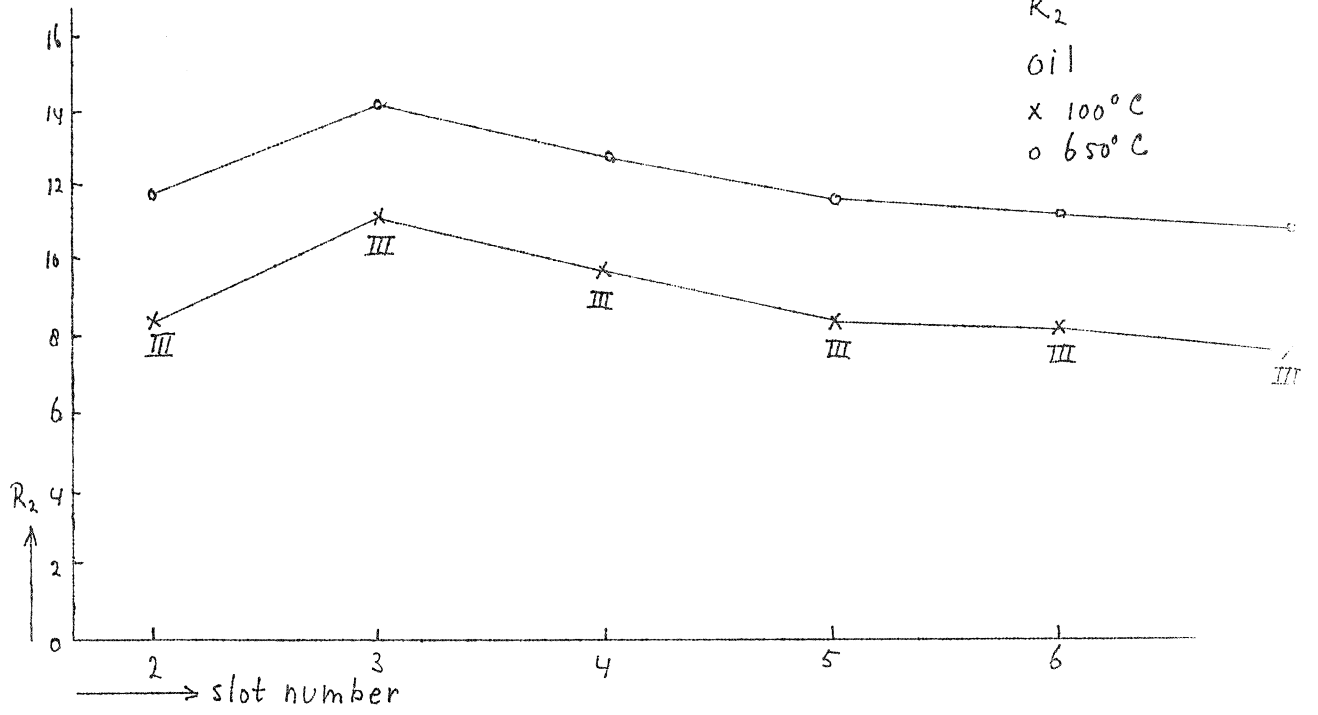

Fig 6.9

R_2
oil
 $\times 100^\circ\text{C}$
 $\circ 650^\circ\text{C}$



gas

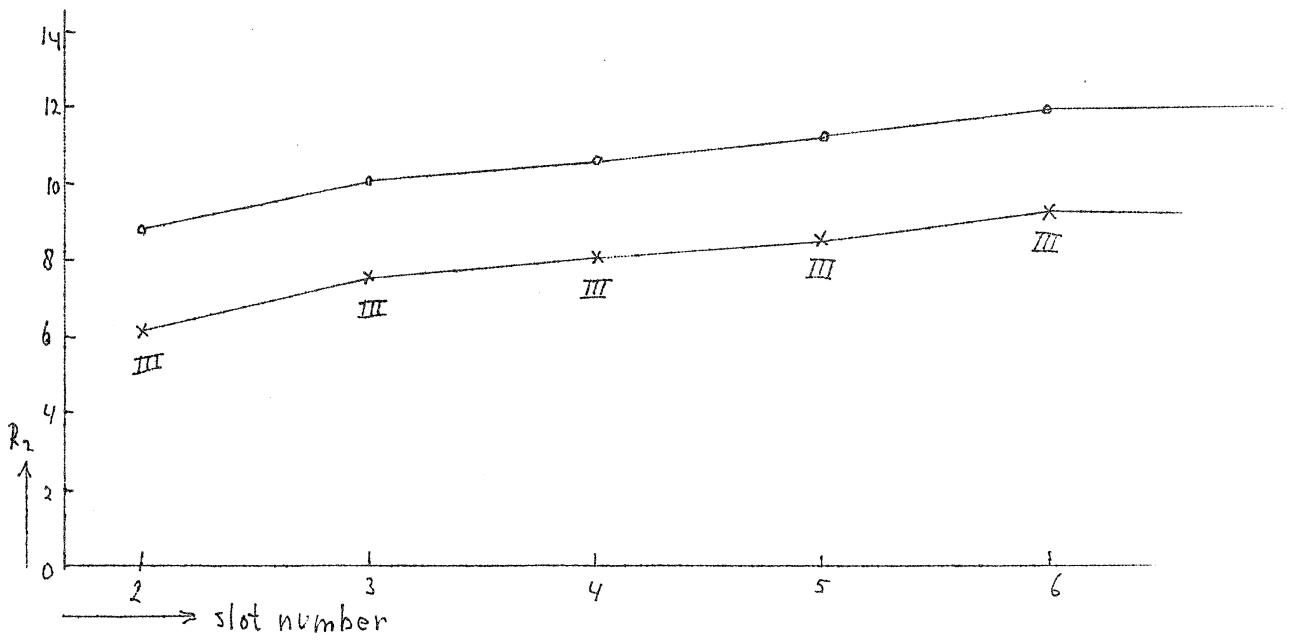
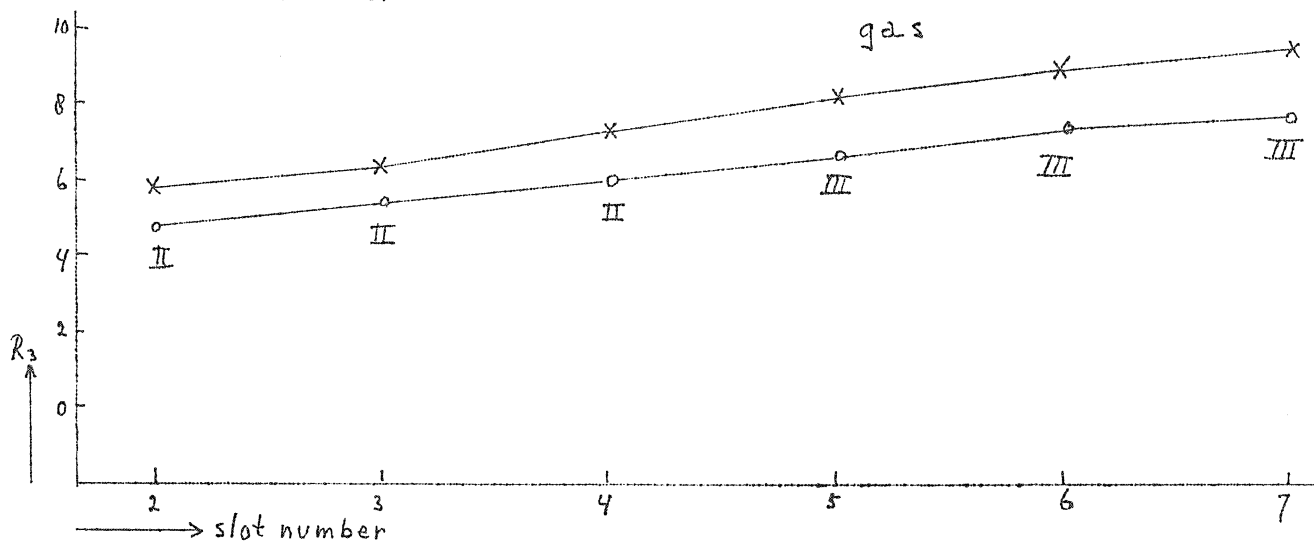
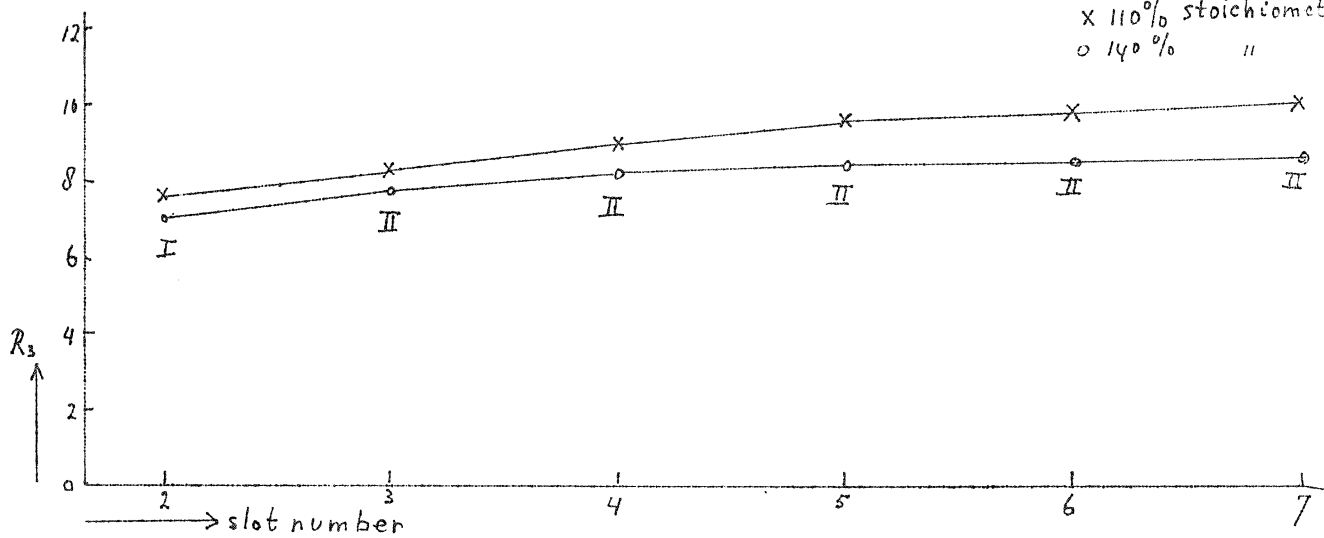

Fig 6.10

oil

R_3
x 110% stoichiometric
o 140% "



oil

Fig 6.11

R_3
x 100°C
o 650°C

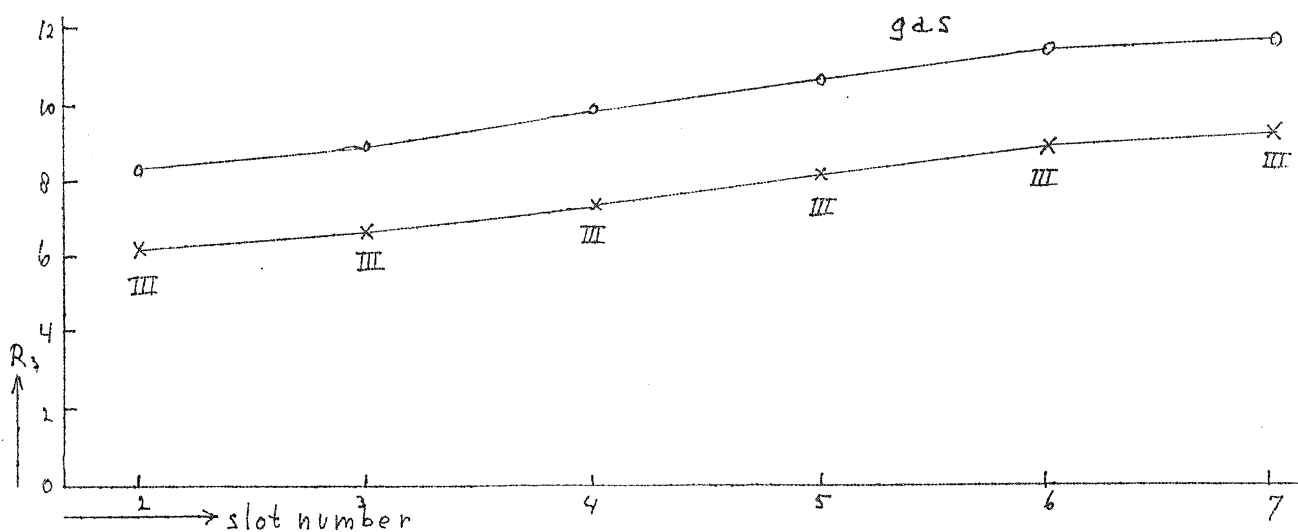
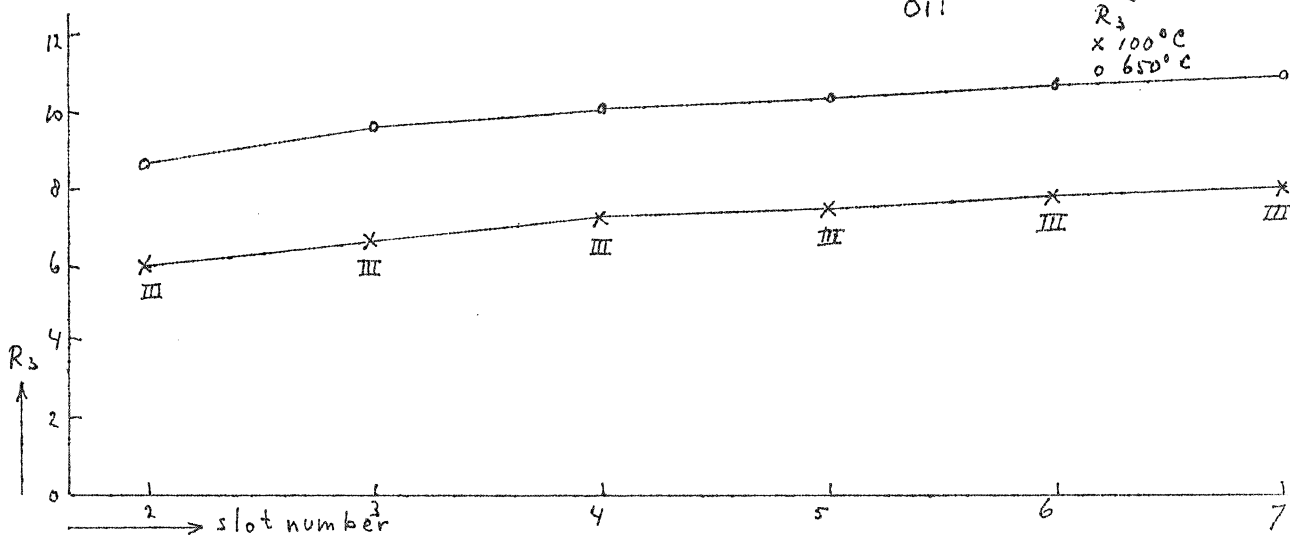

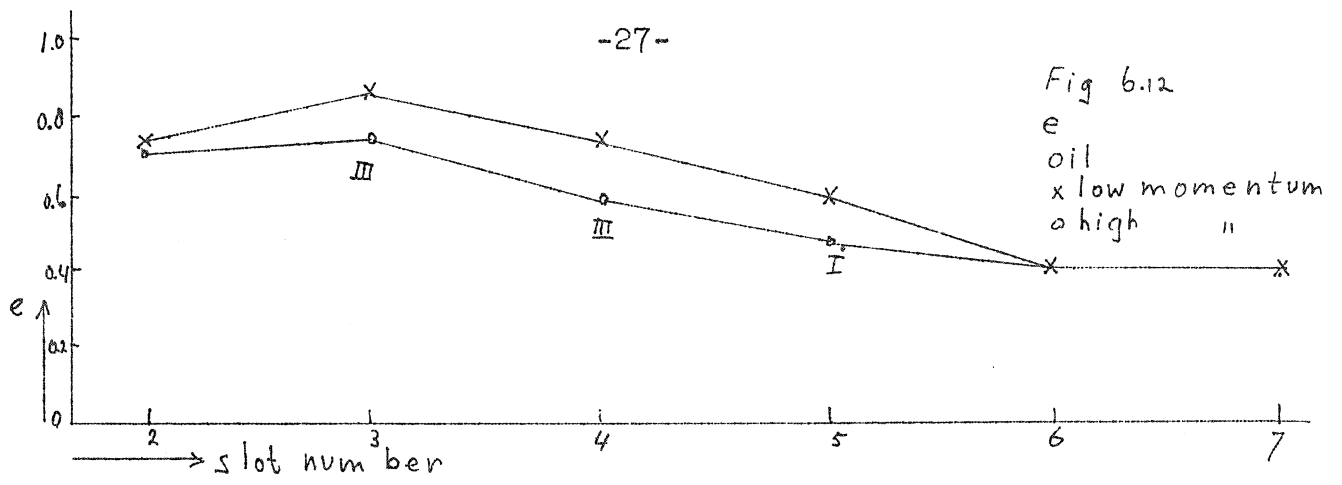

gas

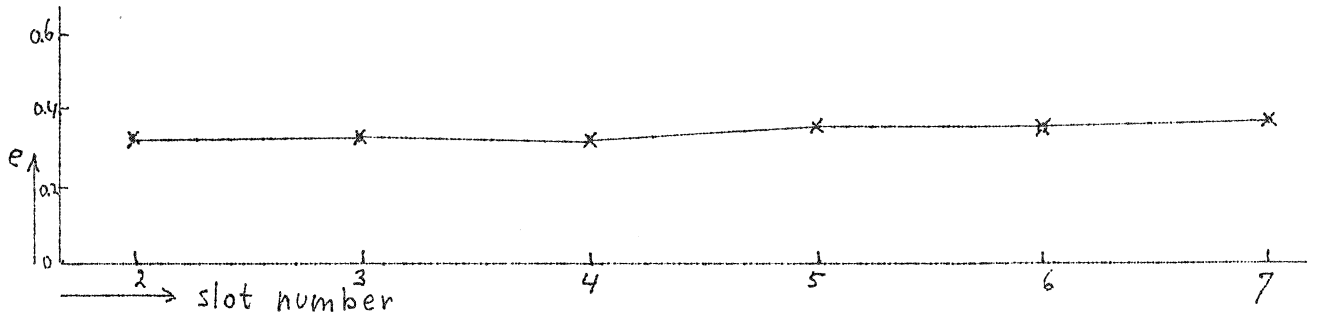
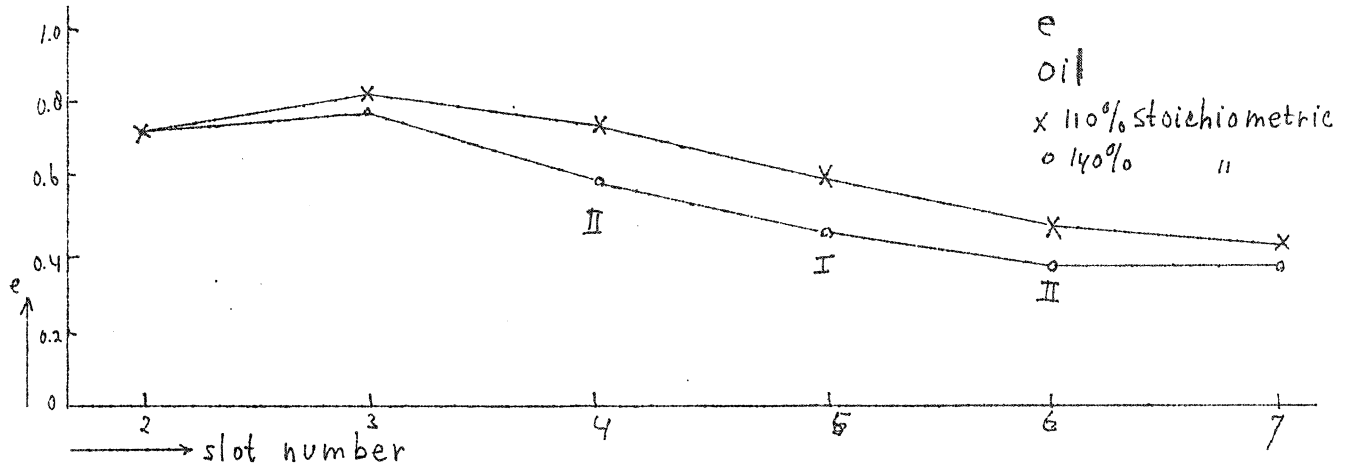

Fig 6.13



gas

