

JW

ON THE BIRTH OF BOUNDARY LAYERS

BY J. GRASMAN

MATHEMATICAL CENTRE TRACTS 36

MATHEMATISCH CENTRUM AMSTERDAM 1971

PREFACE

In recent years a large number of papers dealing with the singular perturbation method has been published. However, only some of these publications refer to the foundation of this method.

In this tract a class of well-known one-dimensional singular perturbation problems is treated in relation with a paper of Eckhaus [5] on the foundations of the method of matched asymptotic expansions.

It is further demonstrated that certain principles underlying the one-dimensional singular perturbation method can be extended in such a way that they serve as a basis for the two-dimensional case. The main reason for studying the basic principles of the two-dimensional method is to give an analytical description of the so-called "birth of a boundary layer", a terminology introduced by Eckhaus [6]. It is a well-known fact that in certain boundary layer problems the usual asymptotic solution is singular at the extremities of the boundary layer, one may say that boundary layers originate in such points. This idea is reflected in the title of this tract.

In the investigation of this type of problems several topics of mathematics are involved such as non-uniform convergence, singular perturbations and the maximum principle. In order to obtain an adequate description of the structure of boundary layers much attention has to be given to the relationship between these topics. As a result of this approach a complete insight into certain types of boundary layer problems is achieved.

I am grateful to the Board of Directors of the "Stichting Mathematisch Centrum" for giving me the opportunity to carry out the investigations presented in this monograph and for publishing this study in the series "Mathematical Centre Tracts".

Valuable suggestions were given during the preparation of this monograph by Professor W. Eckhaus, to whom I would like to express my gratitude.

Finally, I acknowledge Mrs. S. Hillebrand and Miss O de Jong for the typing of the manuscript and Messrs D. Zwarst, J. Suiker and J. Schipper for the printing and the binding.

CONTENTS

CHAPTER I	INTRODUCTION	1
CHAPTER II	DEFINITIONS AND PROPERTIES OF ASYMPTOTIC APPROXIMATIONS	5
CHAPTER III	NON-UNIFORM CONVERGENCE OF FUNCTIONS OF ONE VARIABLE	9
	3.1 Some aspects of non-uniform convergence	9
	3.2 Extension theorems	11
	3.3 Limit functions	12
	3.4 Local asymptotic approximations	14
	3.5 The matching principle	15
	3.6 Uniformly valid asymptotic approximations	17
	3.7 A special case of non-uniform convergence of functions of two variables	21
CHAPTER IV	APPROXIMATIONS OF IMPLICITLY DEFINED FUNCTIONS	27
	4.1 Introductory remarks	27
	4.2 The initial value problem for an ordinary second order differential equation	27
	4.3 The boundary value problem for an ordinary second order differential equation	37
	4.4 The elliptic problem	44
CHAPTER V	NON-UNIFORM CONVERGENCE OF FUNCTIONS OF TWO VARIABLES	50
	5.1 Introductory remarks	50
	5.2 Extension theorems	51
	5.3 Limit functions	52
	5.4 The matching principle	55
	5.5 Local and uniform approximations	69
	5.6 Application to an explicitly given function	82
	5.7 The birth of the parabolic boundary layer	85

CHAPTER VI	THE BIRTH OF A BOUNDARY LAYER IN A LINEAR ELLIPTIC SINGULAR PERTURBATION PROBLEM	89
	6.1 Preliminary remarks	89
	6.2 Locally valid expansions	96
	6.3 Uniformly valid expansions	106
	6.4 Higher order tangency	113
	6.5 A magnetohydrodynamical problem	117
APPENDIX		121
REFERENCES		132
INDEX		137

CHAPTER I INTRODUCTION

Solutions of singular perturbation problems are often obtained by means of heuristic methods, such as coordinate stretching and matching. In order to gain understanding in the fundamental aspects of these methods it is instructive to study the asymptotic behaviour of explicitly given singular functions $\phi(x,y;\epsilon)$ which converge non-uniformly in a closed domain \bar{G} of the x,y -plane when ϵ tends to zero.

Eckhaus [5] demonstrated the usefulness of such an approach for functions of one variable and a small parameter. It is to be expected that a great deal of the results obtained by Eckhaus also hold for functions of two variables and a small parameter. However, it appears that some new aspects arise which are specific for two-dimensional theory. A part of this monograph is dedicated to these matters.

The references [14] and [4] can be considered as introductory studies in the field of matched asymptotic expansions in two variables. The first paper, which was written by the author, deals with the asymptotic behaviour of the exact solution of an elliptic problem. It exhibits the phenomenon of the birth of a parabolic boundary layer. In the second paper Eckhaus studies an elliptic problem which is related to ordinary boundary layers. This paper contains a number of suggestions for the further investigation of the birth of an ordinary boundary layer.

We shall utilise these informations for the study of implicitly defined singular functions (singular perturbation problems). Hereby we restrict our investigation to those functions ϕ , which satisfy linear, ordinary or elliptic, second order differential equations of the type

$$(1.1) \quad L_{\epsilon} \phi \equiv \epsilon L_2 \phi + L_1 \phi = h,$$

where L_2 is a second order and L_1 a first order differential operator. Furthermore, h is a given function and ϵ a small positive parameter. The case where L_1 and L_2 are ordinary differential operators provides the starting point of our investigations.

In two-dimensional singular perturbation problems, which are known from literature, the exact solution converges non-uniformly in the neighbourhood of a curve which may either be contained in the definition domain G or be a part of the boundary. These situations are related to free and ordinary boundary layers, respectively. For such problems a coordinate system (ρ, θ) is introduced in which ρ is normal to the curve and θ varies along the curve.

In the present analysis a formal approximation of the solution of these problems will be constructed in five distinct steps, as follows:

1. The coordinate ρ is stretched by introducing a transformation of the type

$$(1.2) \quad \rho = \xi \varepsilon^\alpha, \quad \alpha \geq 0,$$

$(\rho, \theta) = (0, \theta)$ at the curve. By transforming equation (1.1) into an equation depending on ξ , θ and ε , and by letting ε tend to zero we obtain the degenerated operators $L_0^{(\alpha)}$ for different values of α :

$$\lim_{\varepsilon \rightarrow 0} \varepsilon^\gamma L_\varepsilon = L_0^{(\alpha)},$$

where γ is chosen such that the coefficients of $L_0^{(\alpha)}$ are $O(1)$ in ε .

2. The general solutions of

$$L_0^{(\alpha)} \bar{\psi}_\alpha = \lim_{\varepsilon \rightarrow 0} \varepsilon^\gamma h.$$

are constructed. The functions $\bar{\psi}_\alpha$ are said to be formal limit functions.

3. The matching principle yields relations, which must exist between the integration constants of different formal limit functions.
4. The boundary conditions are satisfied. The formal limit functions are then uniquely determined.
5. A formal uniformly valid approximation is composed of the formal limit functions.

Finally, it must be established that this formal approximation does indeed approximate the exact solution with a certain degree of accuracy. In our approach such a proof is based on the maximum principle for differential equations (see Protter and Weinberger [30]).

When an approximation, obtained in this manner, exhibits a singularity at an isolated point of the curve, it is obvious that stretching must be applied to both coordinates ρ and θ . Thus

$$(1.3) \quad \rho = \xi \varepsilon^\alpha, \quad \theta = \eta \varepsilon^\beta, \quad \alpha, \beta \geq 0,$$

$(\rho, \theta) = (0, 0)$ at the singular point. In order to achieve a formal uniformly valid approximation the same five steps must be passed through.

Our main objective is to solve the elliptic singular perturbation problem of the function $\Phi(x, y; \varepsilon)$ satisfying (1.1) in a bounded strictly convex domain G with given boundary values.

This problem has been the subject of a large number of papers. In chronological order we mention Wasow [34], Levinson [21], Visik and Lyusternik [34], Eckhaus and De Jager [7], Mauss [24] and [28], Roberts [31], Frankema [11] and De Groen [17].

In the present monograph two aspects can be distinguished: the study of non-uniform convergence of explicitly given functions, and, in addition, the method of constructing formal approximations of implicitly defined functions. These two aspects are, to a certain degree, complementary. Therefore, the former can never be used to prove the validity of the latter. However, the study of non-uniformly converging functions reveals some essential features of singular perturbation problems, which enables us to understand the boundary layer mechanism.

Some definitions and properties of asymptotic approximations are reviewed in chapter 2. In this manner we indicate which concepts of perturbation theory are used in the sequel.

In chapter 3, a summary is given of the paper of Eckhaus [5] which deals with the foundation of matched asymptotic expansions in one variable. Only those subjects are treated which are important in the present study. In

section 3.7, the author considers a two-dimensional boundary layer structure, which can be interpreted in terms of Eckhaus' analysis.

Chapter 4 is devoted to a class of solution methods of well-known singular perturbation problems. Some seemingly arbitrary procedures in these methods are interpreted as natural results from theory discussed in chapter 3. Moreover, the validity of the approximating solutions is proved by means of the maximum principle.

In chapter 5, new results are obtained concerning non-uniform convergence of functions of two variables and a small parameter. The use of the method is demonstrated for so-called parabolic boundary layers.

In chapter 6, an analysis of the elliptic problem, mentioned above, is made. Besides a complete explanation and description of the singular behaviour of the solution, which results in a clear picture of the birth of an ordinary boundary layer, we also give the proof of validity of a uniform approximation. Moreover, a physical application of the elliptic problem is discussed.

CHAPTER II DEFINITIONS AND PROPERTIES OF ASYMPTOTIC APPROXIMATIONS

In the following chapters we will express the order of magnitude of a function $\phi(s;\epsilon)$ ($s=x$ or $s=(x,y)$, $0<\epsilon\ll 1$) by means of functions which depend only on ϵ . For this purpose we introduce so-called order functions. Let $\delta(\epsilon)$ be a real, positive, continuous function of the real variable ϵ on an interval $0 < \epsilon \leq \epsilon_0$, and let $\lim_{\epsilon \rightarrow 0} \delta(\epsilon)$ exist, then every function having these properties is said to be an order function. When a comparison between two order functions is made, the following notations are used:

$$(2.1a) \quad \delta_1 \underset{\text{as}}{<} \delta_2, \quad \text{if } \delta_1/\delta_2 \text{ is bounded for } \epsilon \rightarrow 0,$$

$$(2.1b) \quad \delta_1 \underset{\text{as}}{=} \delta_2, \quad \text{if } \delta_1 \underset{\text{as}}{<} \delta_2 \text{ and } \delta_2 \underset{\text{as}}{<} \delta_1,$$

$$(2.1c) \quad \delta_1 \underset{\text{as}}{\ll} \delta_2, \quad \text{if } \lim_{\epsilon \rightarrow 0} \delta_1/\delta_2 = 0.$$

The signs $\underset{\text{as}}{=}$, $\underset{\text{as}}{<}$, $\underset{\text{as}}{\ll}$ indicate the asymptotic ordering between two samples of the set of order functions. The relationship between two order functions given by such a sign does not imply a same relation with the usual equality and inequality signs. It is emphasized that the set of order functions is only partially ordered in this manner.

If $\delta_1 \underset{\text{as}}{=} \delta_2$, the functions δ_1 and δ_2 are called asymptotically equal. From the set of order functions infinite denumerable subsets can be chosen forming a function sequence δ_n with the property

$$\delta_{n+1} \underset{\text{as}}{\ll} \delta_n, \quad n = 0, 1, 2, \dots .$$

For any such sequence the following lemma holds.

Lemma 2.1 Let $\delta_n(\epsilon)$ be a sequence of order functions with the property

$$\delta_{n+1} \underset{\text{as}}{\ll} \delta_n, \quad n = 0, 1, 2, \dots,$$

then order functions $\delta^*(\epsilon)$ exist such that

$$\delta^* \underset{\text{as}}{\ll} \delta_n$$

for all n .

Any order function $\delta^*(\varepsilon)$ having this property will be called asymptotically equivalent to zero with respect to the sequence $\delta_n(\varepsilon)$. Lemma 2.1 is closely related to the DuBois-Reymond theorem [5].

Definition 2.1 $\phi(s; \varepsilon)$ is $O(\delta(\varepsilon))$ in D , if there exist constants ε_0 and K such that $M(\varepsilon) \stackrel{\text{def}}{=} \underset{D}{\text{Max}} |\phi(s; \varepsilon)| \leq K\delta(\varepsilon)$ for $0 < \varepsilon < \varepsilon_0$, and $\lim_{\varepsilon \rightarrow 0} M(\varepsilon)/\delta(\varepsilon) \neq 0$, if this limit exists.

Remark This definition differs from the one Landau used: if $\phi = O(\delta_e(\varepsilon))$ $\delta_e(\varepsilon) \underset{\text{as}}{\ll} \delta(\varepsilon)$, then according to Landau's definition we may say that $\phi = O(\delta(\varepsilon))$. However, from definition 2.1 it follows that in this case $\phi \neq O(\delta(\varepsilon))$.

Definition 2.2 Two functions $\phi(s; \varepsilon)$ and $\bar{\phi}_0(s; \varepsilon)$ are asymptotically equivalent in D , if $\phi(s; \varepsilon) = O(\delta_0(\varepsilon))$, $\bar{\phi}_0(s; \varepsilon) = O(\delta_0(\varepsilon))$, $\phi(s; \varepsilon) - \bar{\phi}_0(s; \varepsilon) = O(\delta_1(\varepsilon))$ and $\delta_1(\varepsilon) \underset{\text{as}}{\ll} \delta_0(\varepsilon)$. In such a case we write $\phi \simeq \bar{\phi}_0$.

With the aid of these definitions we are able to describe the way to obtain an asymptotic expansion of a function $\phi(s; \varepsilon)$. When $\phi(s; \varepsilon) = O(\delta_0(\varepsilon))$, we construct an approximation of type

$$\phi(s; \varepsilon) \simeq \phi_0(s; \varepsilon) \delta_0(\varepsilon).$$

(At this stage we do not study the manner in which such an approximation is obtained.) Let

$$\phi(s; \varepsilon) - \phi_0(s; \varepsilon) \delta_0(\varepsilon) = O(\delta_1(\varepsilon)),$$

then the construction of a higher order approximation is achieved, if we find a function $\phi_1(s; \varepsilon)$ that satisfies

$$(2.2) \quad \phi(s; \varepsilon) - \phi_0(s; \varepsilon) \delta_0(\varepsilon) \simeq \phi_1(s; \varepsilon) \delta_1(\varepsilon).$$

If this construction of higher order approximations is continued indefinitely, we obtain the asymptotic series

$$\phi(s; \varepsilon) = \sum_{m=0}^{\infty} \delta_m(\varepsilon) \phi_m(s; \varepsilon) + R(s; \varepsilon),$$

where $R(s; \varepsilon) \underset{as}{=} \delta^*(\varepsilon)$ for all $s \in D$ and $\delta^*(\varepsilon)$ is asymptotically equivalent to zero with respect to the sequence $\delta_n(\varepsilon)$ (see Lemma 2.1).

The following lemma of [5] establishes the asymptotic equivalence of $\phi(s; \varepsilon)$ and the approximation $\phi_0(s; \varepsilon)$.

Lemma 2.2 Let $\phi(s; \varepsilon)$ and $\phi_0(s; \varepsilon)$ be continuous functions in D for $0 < \varepsilon \leq \varepsilon_0$, and let both functions be of order $O(1)$. Then $\phi(s; \varepsilon)$ and $\phi_0(s; \varepsilon)$ are asymptotically equivalent if, and only if, the limit

$$\lim_{\varepsilon \rightarrow 0} |\phi(s; \varepsilon) - \phi_0(s; \varepsilon)| = 0$$

holds uniformly in D .

When the limit $\lim_{\varepsilon \rightarrow 0} \phi(s; \varepsilon) = \omega_0(s)$ converges uniformly in D , it is easily deduced from lemma 2.2 that an order function $\delta_1(\varepsilon)$ exists such that

$$|\phi(s; \varepsilon) - \omega_0(s)| \underset{as}{=} \delta_1(\varepsilon) \underset{as}{\ll} 1 \quad \text{for all } s \in D,$$

or

$$\phi(s; \varepsilon) = \omega_0(s) + O(\delta_1).$$

Functions $\phi(s; \varepsilon)$ which have the property that the limit $\lim_{\varepsilon \rightarrow 0} \phi(s; \varepsilon)$ exists and converges uniformly in D are called regular. If the limit converges non-uniformly in D the functions $\phi(s; \varepsilon)$ are called singular. For the higher order terms (see (2.2)) we have to reconsider this problem, because $\lim_{\varepsilon \rightarrow 0} (\phi - \phi_0 \delta_0) / \delta_1$ may converge uniformly or non-uniformly independently of the course of the foregoing term.

In the sequel, we only study the case where $\phi(s;\varepsilon)$ is a singular function for which the non-uniformity occurs near isolated points in a closed interval of the x -axis, if $s = x$. For $s = (x,y)$ we may have non-uniform convergence near both curves and isolated points in a closed domain of the x,y -plane.

CHAPTER III NON-UNIFORM CONVERGENCE OF FUNCTIONS OF ONE VARIABLE

3.1 SOME ASPECTS OF NON-UNIFORM CONVERGENCE

It is assumed that $\phi(x;\epsilon)$ is a continuous function of x and the parameter ϵ in the domain $G_\epsilon = \{x, \epsilon: 0 \leq x \leq R, 0 < \epsilon \leq \epsilon^*\}$ and that $\omega(x)$ is a continuous function in $G = \{x: 0 < x \leq R\}$. Moreover, the limit

$$(3.1) \quad \lim_{\epsilon \rightarrow 0} [\phi(x;\epsilon) - \omega(x)] = 0$$

converges non-uniformly in G , and uniformly in $\bar{G} - G_A$, where $G_A = \{x: 0 \leq x < A\}$ and A is an arbitrary positive constant. Thus, for any number $q > 0$, a number $\epsilon_0(q)$ exists such that $|\phi(x;\epsilon) - \omega(x)| \leq q$, if $0 < \epsilon \leq \epsilon_0(q)$ and $A \leq x \leq R$.

As a consequence of the non-uniform convergence the upper bound of ϵ also depends on the choice of A . This dependence is such that

$$\lim_{A \rightarrow 0} \epsilon_0(q, A) = 0.$$

Of all possible functions $\epsilon_0(q, x)$ we chose those (defined for $0 \leq x \leq R$ and $0 < q \leq q_0$) which satisfy the following conditions:

- a. $|\phi(x;\epsilon) - \omega(x)| \leq q$, if $0 < \epsilon \leq \epsilon_0(q, x)$ and $0 < x \leq R$,
- b. $\epsilon_0(q, x)$ is continuous in q and x ,
- c. $\epsilon_0(q, x)$ is monotonic increasing in q and x ,
- d. $\lim_{q \rightarrow 0} \epsilon_0(q, x) = 0$, $\lim_{x \rightarrow 0} \epsilon_0(q, x) = 0$,
- e. For any $\lambda > 0$ values x_k within $0 < x_k \leq \lambda$ exist such that $|\phi(x_k;\epsilon) - \omega(x_k)| > q$ for $\epsilon = \epsilon_0(q, x_k) + \sigma$, where $\sigma > 0$ is arbitrarily small.

The functions $\varepsilon_0(q, x)$ satisfying these conditions are particularly adapted to describe the behaviour of the non-uniformly converging limit (3.1), as we shall verify in the following three points.

1. $|\phi(x, \varepsilon) - \omega(x)| \leq q$, if $0 < \varepsilon \leq p(q, A)$, where $p(q, A) = \min_{A < x < R} \varepsilon_0(q, x)$.
Thus the convergence is indeed uniform for $0 < A \leq x \leq R$.
2. We show that the limit is non-uniform for $0 < x \leq R$ by assuming the opposite. In that case for any q ($0 < q \leq q_0$) a number $\mu(q)$ would exist such that for $0 < \varepsilon \leq \mu(q)$ and $0 < x \leq R$ relation $|\phi(x; \varepsilon) - \omega(x)| < q$ would hold. However, for x sufficiently small we would have $\mu(q) > \varepsilon_0(q, x)$, which contradicts condition e.
3. The existence of functions $\varepsilon_0(q, x)$ is easily established by assuming the opposite. This would lead to uniform convergence for $0 < x \leq R$. Moreover, we can prove that any two functions of this set $\varepsilon_0(q, x)$ tend to zero in the same way:

$$\lim_{q \rightarrow 0} \frac{\varepsilon_0^{(1)}(q, x)}{\varepsilon_0^{(2)}(q, x)} \neq 0 \quad \text{and} \quad \lim_{x \rightarrow 0} \frac{\varepsilon_0^{(1)}(q, x)}{\varepsilon_0^{(2)}(q, x)} \neq 0$$

Finally, a lemma is proved that will be of great value in the following section.

Lemma 3.1 Let $\varepsilon_0(q, x)$ be a function with the properties a, ..., e, then there exist functions $\bar{\varepsilon}_0(x)$ with $\lim_{x \rightarrow 0} \frac{\bar{\varepsilon}_0(x)}{\varepsilon_0(q, x)} = 0$ for all q .

Proof Let $r(x)$ be a monotonic increasing function with $\lim_{x \rightarrow 0} r(x) = 0$. For $0 < q_2 < q_1 \leq q_0$, two possibilities are distinguished:

1. $\lim_{x \rightarrow 0} \frac{\varepsilon_0(q_2, x)}{\varepsilon_0(q_1, x)} \neq 0$, then $\bar{\varepsilon}_0(x) = r(x) \varepsilon_0(q_0, x)$,
2. $\lim_{x \rightarrow 0} \frac{\varepsilon_0(q_2, x)}{\varepsilon_0(q_1, x)} = 0$, then $\bar{\varepsilon}_0(x) = \varepsilon_0(r(x), x)$.

3.2 EXTENSION THEOREMS

It appears that the domain of uniform convergence of the limit (3.1) can be extended in such a way that the origin also is included. Using the properties of non-uniform convergence, as given in the preceding section, we will investigate the bounds of the extended domain of convergence. The term "uniform convergence" is considered here from another point of view than the classical definition. A formulation is obtained which turns out to be appropriate to our case. The following definition will be used:

Definition 3.1 Let P_ϵ be a domain of the s, ϵ -space ($\epsilon > 0$), containing an interval S of the s -space for $\epsilon = 0$. Then we say that the limit

$$\lim_{\epsilon \rightarrow 0} [\phi(s; \epsilon) - \omega(s)] = 0$$

is uniform in P_ϵ , if for all values $s = s_1$ contained in S

$$\lim_{\substack{\epsilon \rightarrow 0 \\ s \rightarrow s_1}} [\phi(s; \epsilon) - \omega(s)] = 0$$

independently of the choice of the path in P_ϵ .

With the aid of lemma 2.1 the extension theorems 3.1 and 3.2 are proved (see [5]).

Theorem 3.1 Let $\phi(x; \epsilon)$ be a continuous function in $G_\epsilon = \{x, \epsilon: 0 \leq x \leq R, 0 < \epsilon \leq \epsilon_0^*\}$, and let the limit

$$\lim_{\epsilon \rightarrow 0} [\phi(x; \epsilon) - \omega(x)] = 0$$

hold uniformly on the interval $0 < A \leq x \leq R$ for any value of A and R being fixed. Then there exist functions $\epsilon = \bar{\epsilon}_0(x)$, positive, continuous and monotonic increasing with $\lim_{\epsilon \rightarrow 0} \bar{\epsilon}_0(x) = 0$, such that the limit

$$\lim_{\epsilon \rightarrow 0} [\phi(x; \epsilon) - \omega(x)] = 0$$

is uniformly valid in $P_\varepsilon = \{x, \varepsilon: 0 \leq x \leq R, 0 \leq \varepsilon \leq \bar{\varepsilon}_0(x)\}$.

Theorem 3.2 Let $\phi(x; \varepsilon)$ be a continuous function in $G_\varepsilon = \{x, \varepsilon: 0 \leq x \leq R, 0 < \varepsilon \leq \varepsilon^*\}$, and let the limit

$$\lim_{\varepsilon \rightarrow 0} [\phi(x; \varepsilon) - \omega(x)] = 0$$

hold uniformly on the interval $0 < A \leq x \leq B < R$ for any A, B and R being fixed. Then there exist functions $\varepsilon = \bar{\varepsilon}_0(x)$, as defined in theorem 3.1, and moreover, functions $\varepsilon = \underline{\varepsilon}_0(x)$, positive, continuous and monotonic decreasing with $\lim_{x \rightarrow R} \bar{\varepsilon}_0(x) = 0$, such that the limit

$$\lim_{\varepsilon \rightarrow 0} [\phi(x; \varepsilon) - \omega(x)] = 0$$

is uniformly valid in $P_\varepsilon = \{x, \varepsilon: 0 \leq x \leq R, 0 \leq \varepsilon \leq \min[\bar{\varepsilon}_0, \underline{\varepsilon}_0, \varepsilon^*]\}$. (R may tend to infinity.)

3.3 LIMIT FUNCTIONS

The non-uniformly converging function $\phi(x; \varepsilon)$, defined in section 3.1, will be studied more precisely. Using theorem 3.1 we obtain an extended domain of uniform convergence $P_\varepsilon = \{x, \varepsilon: 0 \leq x \leq R, 0 \leq \varepsilon \leq \bar{\varepsilon}_0(x)\}$. An inverse function of $\varepsilon = \bar{\varepsilon}_0(x)$ exists, because $\varepsilon = \bar{\varepsilon}_0(x)$ is continuous and monotonic increasing. Clearly, this inverse function, say $\bar{\delta}_0(\varepsilon)$, is an order function with $\lim_{\varepsilon \rightarrow 0} \bar{\delta}_0(\varepsilon) = 0$.

It is also possible to introduce an inverse function of $\varepsilon = \varepsilon_0(q, x)$. Let $x = \delta_0^{(q)}(\varepsilon)$ be this inverse. We easily verify that $\delta_0^{(q)}(\varepsilon)$ has the properties

1. $\delta_0^{(q)}(\varepsilon)$ is an order function,
2. $\lim_{\varepsilon \rightarrow 0} \delta_0^{(q)}(\varepsilon) = 0$, $0 < q \leq q_0$,
3. $\delta_0^{(q_1)} <_{\text{as}} \delta_0^{(q_2)}$, $0 < q_2 < q_1 \leq q_0$.

Because of the relationship existing between the functions $\varepsilon_0(q, x)$ and $\bar{\varepsilon}_0(x)$, the following asymptotic inequality is valid:

$$\delta_0^{(q)} \ll_{\text{as}} \bar{\delta}_0 \ll_{\text{as}} 1.$$

This relation implies that the set of functions $\bar{\delta}_0(\varepsilon)$ is bounded by the set of functions $\delta_0^{(q)}(\varepsilon)$.

When a given function belongs to a set of asymptotically equal order functions $\delta(\varepsilon)$, other samples of this set are easily constructed by multiplying this function by a constant. Therefore, within the domain of uniform convergence we may consider a family of paths given by

$$(3.2) \quad x = \xi \delta(\varepsilon),$$

so that the limit

$$(3.3) \quad \lim_{\varepsilon \rightarrow 0} [\phi(x; \varepsilon) - \omega(x)] = 0$$

holds along any such path, if $\delta_0^{(q)} \ll_{\text{as}} \delta \ll_{\text{as}} 1$. Taking the limit (3.3) along a path (3.2) is equivalent to the following manipulations of substituting (3.2) into (3.3) and letting $\varepsilon \rightarrow 0$, while ξ is kept fixed. We shall use for such an operation the notation

$$(3.4) \quad \lim_{\xi} [\phi(x; \varepsilon) - \omega(x)] = 0.$$

The path (3.2) was chosen in the extended domain of convergence of the limit (3.4). On the other hand when the procedure (3.4) is applied to a path

$$(3.5) \quad x = \xi_{\nu} \delta_{\nu}(\varepsilon)$$

without a restriction of type $\delta_0^{(q)} \ll_{\text{as}} \delta_{\nu}$, a generalization of the limit of the singular function $\phi(x; \varepsilon)$ is obtained

$$(3.6) \quad \lim_{\xi_\nu} \left[\frac{\phi(x;\varepsilon)}{\delta_\nu^*(\varepsilon)} - \psi_\nu(\xi_\nu) \right] = 0.$$

Definition 3.2 We say that for a transformation (3.5) the limit of the singular function $\phi(x;\varepsilon)$ exists, if there exists a non-trivial function $\psi_\nu(\xi_\nu)$ and an order function $\delta_\nu^*(\varepsilon)$ such that (3.6) is satisfied on some interval of ξ_ν .

Example 3.1 We consider the singular function

$\phi(x;\varepsilon) = (x^2+2x+2\varepsilon) + (x+x^2) \exp(-x/\varepsilon)$ and construct its generalized limits according to (3.6). We notice that $\omega(x) = x^2+2x$ and that for the paths

$$x = \xi_\nu \varepsilon^\nu$$

the limit functions are

$$\begin{aligned} \psi_\nu &= 2\xi_\nu & , & & \delta_\nu^* &= \varepsilon^\nu, & & 0 < \nu < 1, \\ \psi_\nu &= (2\xi_\nu+2)+\xi_\nu e^{-\xi_\nu} & , & & \delta_\nu^* &= \varepsilon, & & \nu = 1, \\ \psi_\nu &= 2 & , & & \delta_\nu^* &= \varepsilon, & & \nu > 1. \end{aligned}$$

3.4 LOCAL ASYMPTOTIC APPROXIMATIONS

A limit function $\psi_\nu(\xi_\nu)$ can in a certain way be considered as a local asymptotic approximation of the singular function $\phi(x;\varepsilon)$.

Assuming that the limit

$$(3.7) \quad \lim_{\xi_\nu} \left[\frac{\phi(x;\varepsilon)}{\delta_\nu^*(\varepsilon)} - \psi_\nu(\xi_\nu) \right] = 0, \quad x = \xi_\nu \delta_\nu^*(\varepsilon),$$

holds uniformly on the interval $0 < A_\nu \leq \xi_\nu \leq B_\nu < \infty$ with A_ν and B_ν arbitrarily chosen, we obtain by application of lemma 2.2

$$\left| \frac{\phi(x;\varepsilon)}{\delta_\nu^*(\varepsilon)} - \psi_\nu\left(\frac{x}{\delta_\nu^*(\varepsilon)}\right) \right| \underset{\text{as}}{=} \delta_\nu^{(r)}(\varepsilon) \underset{\text{as}}{\ll} 1.$$

Hence

$$\phi(x; \varepsilon) = \psi_{\nu} \left(\frac{x}{\delta_{\nu}(\varepsilon)} \right) \cdot \delta_{\nu}^*(\varepsilon) + o(\delta_{\nu}^{(r)} \cdot \delta_{\nu}^*)$$

for $A_{\nu} \delta_{\nu} \leq x \leq B_{\nu} \delta_{\nu}$. When theorem 3.2 ($R \rightarrow \infty$) is applied to (3.7), an extended domain of convergence is obtained. Let $x = \xi_{\mu} \delta_{\mu}(\varepsilon) = \xi_{\mu} \delta_{\nu}(\varepsilon) \bar{\delta}_{\nu}(\varepsilon)$ (also allowed in $\delta_{\mu} = \delta_{\nu} / \bar{\delta}_{\nu}$) be a path in this domain, then an order function $\delta_{\nu, \mu}^{(r)}(\varepsilon) \ll_{\text{as}} 1$ exists such that

$$\phi(x; \varepsilon) = \psi_{\nu} \left(\frac{x}{\delta_{\nu}} \right) \delta_{\nu}^* + o(\delta_{\nu, \mu}^{(r)} \delta_{\nu}^*)$$

for $A \delta_{\mu} \leq x \leq B \delta_{\mu}$, $0 < A < B < \infty$.

3.5 THE MATCHING PRINCIPLE

With respect to the set of order functions $\delta_0^{(q)}(\varepsilon)$ of section 3.3 two cases will be distinguished. The set may consist of asymptotically equal order functions or it may consist of order functions with the property

$$(3.8) \quad \delta_0^{(q_1)} \ll_{\text{as}} \delta_0^{(q_2)}, \quad 0 < q_2 < q_1 \leq q_0.$$

Two examples are given: $\delta_0^{(q)}(\varepsilon) = q\varepsilon$ is a set of asymptotically equal order functions, and $\delta_0^{(q)}(\varepsilon) = \varepsilon^q$ is a set of order functions satisfying (3.8). In the present analysis we study the case where the bounding sets $\delta_0^{(q)}(\varepsilon)$ consist of asymptotically equal order functions.

The matching principle is contained in the following theorem (for proof and details see [5]). It is used to determine unknown constants in local approximations of a function $\phi(x; \varepsilon)$ in cases where such a function is implicitly defined by differential equations (see example 3.2).

Theorem 3.3 Let

$$(3.9) \quad \lim_{\xi_{\nu_1}} \left[\frac{\phi(x; \varepsilon)}{\delta_{\nu_1}^*(\varepsilon)} - \psi_{\nu_1}(\xi_{\nu_1}) \right] = 0,$$

and

$$(3.10) \quad \lim_{\xi_{v_1}} \left[\frac{\phi(x; \varepsilon)}{\delta_{v_2}^*(\varepsilon)} - \psi_{v_2}(\xi_{v_2}) \right] = 0,$$

where $x = \xi_{v_1} \delta_{v_1}(\varepsilon) = \xi_{v_2} \delta_{v_2}(\varepsilon)$.

Then an order function $\hat{\delta}_v^{(1,2)}(\varepsilon) \ll_{\text{as}} 1$ exists such that for $\hat{\delta}_v^{(1,2)} \ll_{\text{as}} \frac{\delta_{v_2}}{\delta_{v_1}} \ll_{\text{as}} 1$ the following relation holds:

$$(3.11) \quad \lim_{\xi_\mu} \left[\frac{\delta_{v_1}}{\delta_\mu} \psi_{v_1} \left(\frac{\delta_\mu}{\delta_{v_1}} \xi_\mu \right) \right] = \lim_{\xi_\mu} \left[\frac{\delta_{v_2}}{\delta_\mu} \psi_{v_2} \left(\frac{\delta_\mu}{\delta_{v_2}} \xi_\mu \right) \right],$$

$$x = \xi_\mu \delta_\mu(\varepsilon), \quad \delta_{v_2} \ll_{\text{as}} \delta_\mu \ll_{\text{as}} \delta_{v_1}$$

Both limits must exist and be non-trivial.

Example 3.2 The function $\phi(x; \varepsilon)$ has the following properties:

1. $\lim_{\varepsilon \rightarrow 0} [\phi(x; \varepsilon) - \omega(x)] = 0, \quad \omega(x) = \frac{\sin 2x}{1+x^2} \quad \text{for } x > 0,$
2. $\lim_{\xi_v} \left[\frac{\phi}{\delta_v^*} - \psi_v(\xi_v) \right] = 0, \quad x = \xi_v \varepsilon^v, \quad 0 < v < 1,$

where $\psi_v(\xi_v) = C_v \xi_v$ and $\delta_v^* = \varepsilon^v$,

3. $\lim_{\xi_1} \left[\frac{\phi}{\delta_1^*} - \psi_1(\xi_1) \right] = 0, \quad x = \xi_1 \varepsilon,$

where $\psi_1(\xi_1) = C_1 \xi_1 e^{1/\xi_1} + C_0$ and $\delta_1^* = \varepsilon$.

Applying theorem 3.3 to two limit functions ψ_{v_1} and ψ_{v_2} , $0 < v_1 < v_2 < 1$, we obtain $C_{v_1} = C_{v_2} = C$, so for all $0 < v < 1$ we have

$C_\nu = C$. Matching $\omega(x)$ and ψ_{ν_0} , where ν_0 is chosen such that the condition $\hat{\delta}^{(1,2)} \ll_{\text{as}} \delta_{\nu_0} \ll_{\text{as}} 1$ of theorem 3.3 is satisfied, yields $C = 2$. Finally, matching ψ_1 and ψ_{ν_1} of the set $0 < \nu_1 < 1$, where ν_1 is chosen such that $\hat{\delta}^{(1,2)} \ll_{\text{as}} \delta_1 / \delta_{\nu_1} \ll_{\text{as}} 1$ is satisfied, leads to the result

$$C_1 = C_\nu = C = 2, \quad C_0 = 0.$$

3.6 UNIFORMLY VALID ASYMPTOTIC APPROXIMATIONS

We will apply the results just obtained for the construction of an asymptotic approximation of a singular function which holds uniformly in the definition domain of this function. It is assumed that the function $\phi(x; \varepsilon)$, defined in $G_\varepsilon = \{x; \varepsilon: 0 < x < R, 0 < \varepsilon < \varepsilon^*\}$, is continuous in x and ε .

To begin with we determine the function $\omega(x)$ satisfying

$$(3.12) \quad \lim_{\xi_\nu} [\phi(x; \varepsilon) - \omega(x)] = 0, \quad x = \xi_\nu \delta_\nu, \quad \delta_0^{(q)} \ll_{\text{as}} \delta_\nu <_{\text{as}} 1.$$

According to definition 3.2 a limit function $\psi_\nu(\xi_\nu)$ can be introduced that satisfies

$$(3.13) \quad \lim_{\xi_\nu} \left[\frac{\phi(x; \varepsilon)}{\delta_\nu^*(\varepsilon)} - \psi_\nu(\xi_\nu) \right] = 0, \quad x = \xi_\nu \delta_\nu, \quad \delta_\nu <_{\text{as}} 1.$$

Obviously, the limit functions $\psi_\nu(\xi_\nu)$ corresponding to the paths $x = \xi_\nu \delta_\nu$ ($\delta_0^{(q)} \ll_{\text{as}} \delta_\nu <_{\text{as}} 1$) can also be obtained from the function $\omega(x)$, because (3.12) converges uniformly along these paths, so

$$(3.14) \quad \lim_{\xi_\nu} \frac{\omega(\xi_\nu \delta_\nu)}{\delta_\nu^*} = \psi_\nu(\xi_\nu), \quad \delta_0^{(q)} \ll_{\text{as}} \delta_\nu <_{\text{as}} 1.$$

Continuing with (3.13) a limit function $\psi_1(\xi_1)$ is defined by

$$\lim_{\xi_1} \left[\frac{\phi}{\delta_1^*} - \psi_1(\xi_1) \right] = 0, \quad x = \xi_1 \delta_1, \quad \delta_1 \stackrel{\text{as}}{=} \delta_0^{(q)}.$$

Furthermore, we apply theorem 3.3 so that for an appropriately chosen order function $\delta_{\nu_1}(\varepsilon)$ we find the relation

$$(3.15) \quad \lim_{\xi_\mu} \left[\frac{\delta_1^*}{\delta_\mu^*} \psi_1 \left(\frac{\delta_\mu}{\delta_1} \xi_\mu \right) \right] = \lim_{\xi_\mu} \left[\frac{\delta_{v_1}^*}{\delta_\mu} \psi_{v_1} \left(\frac{\delta_\mu}{\delta_{v_1}} \xi_\mu \right) \right], \quad \delta_1 \ll \delta_\mu < \delta_{v_1} \ll 1.$$

If δ_{v_1} is sufficiently close to δ_1 in order of magnitude it is allowed to take the path $x = \xi_\mu \delta_\mu(\epsilon)$, $\delta_\mu(\epsilon) \equiv \delta_{v_1}(\epsilon)$, and (3.15) then transforms into

$$(3.16) \quad \lim_{\xi_{v_1}} \left[\frac{\delta_1^*}{\delta_{v_1}^*} \psi_1 \left(\frac{\delta_{v_1}}{\delta_1} \xi_{v_1} \right) \right] = \psi_{v_1}(\xi_{v_1}).$$

Combination of (3.14) and (3.16) yields the relation

$$(3.17) \quad \lim_{\xi_{v_1}} \left[\frac{\delta_1^*}{\delta_{v_1}^*} \psi_1 \left(\frac{\delta_{v_1}}{\delta_1} \xi_{v_1} \right) \right] = \psi_{v_1}(\xi_{v_1}) = \lim_{\xi_{v_1}} \left[\frac{\omega(\xi_{v_1}, \delta_{v_1})}{\delta_{v_1}^*} \right].$$

Applying theorem 3.3 to the limit function $\psi_1(\xi_1)$, we obtain

$$\lim_{\xi_v} \left[\frac{\phi}{\delta_1^*} - \psi_1(\xi_1) \right] = 0, \quad x = \xi_v \delta_v, \quad \delta_1^{(q)} \ll \delta_v < \delta_1.$$

Once more a limit function is introduced,

$$\lim_{\xi_2} \left[\frac{\phi}{\delta_2^*} - \psi_2(\xi_2) \right] = 0, \quad x = \xi_2 \delta_2, \quad \delta_2 \approx \delta_1^{(q)}.$$

Similar to (3.17) we have the relation

$$(3.18) \quad \lim_{\xi_{v_2}} \left[\frac{\delta_2^*}{\delta_{v_2}^*} \psi_2 \left(\frac{\delta_{v_2}}{\delta_2} \xi_{v_2} \right) \right] = \psi_{v_2}(\xi_{v_2}) = \lim_{\xi_{v_2}} \left[\frac{\delta_1^*}{\delta_{v_2}^*} \psi_1 \left(\frac{\delta_{v_2}}{\delta_1} \xi_{v_2} \right) \right],$$

$$\delta_2 \ll \delta_{v_2} \ll \delta_1.$$

Continuation of the procedure leads to a denumerable sequence of limit functions $\psi_n(\xi_n)$. This sequence ends with the construction of a limit function $\psi_m(\xi_m)$ of which the corresponding limit.

$$(3.19) \quad \lim_{\xi_m} \left[\frac{\phi}{\delta_m^*} - \psi_m(\xi_m) \right] = 0$$

holds uniformly for $\xi_m \geq 0$ and $0 \leq \varepsilon \leq \varepsilon^*$. Finally, the function $\phi_0(x; \varepsilon)$ is introduced, which is a composition of the foregoing limit functions:

$$(3.20) \quad \phi_0(x; \varepsilon) = \omega(x) - \psi_{\nu_1} \left(\frac{x}{\delta_{\nu_1}} \right) \delta_{\nu_1}^* + \sum_{n=1}^m \psi_n \left(\frac{x}{\delta_n} \right) \delta_n^* - \sum_{n=1}^{m-1} \psi_{\nu_{n+1}} \left(\frac{x}{\delta_{\nu_{n+1}}} \right) \delta_{\nu_{n+1}}^*.$$

In [5] it is shown that $\phi_0(x; \varepsilon)$ approximates the function $\phi(x; \varepsilon)$ uniformly on the interval $0 \leq x \leq R$. It means that for $0 \leq x_1 \leq R$ the limit

$$(3.21) \quad \lim_{\substack{\varepsilon \rightarrow 0 \\ x \rightarrow x_1}} [\phi(x; \varepsilon) - \phi_0(x; \varepsilon)] = 0$$

is valid along all paths contained in the domain

$$P_\varepsilon = \{x, \varepsilon: 0 \leq x \leq R, 0 \leq \varepsilon \leq \bar{\varepsilon}_0(x)\} \text{ and ending at } (x, \varepsilon) = (x_1, 0).$$

From lemma 2.2 we deduce that because of the uniform convergence of (3.21), there exists an order function $\delta_1^{(r)}(\varepsilon)$ such that

$$|\phi(x; \varepsilon) - \phi_0(x; \varepsilon)| \underset{\text{as}}{=} \delta_1^{(r)}(\varepsilon) \underset{\text{as}}{\ll} 1.$$

We introduce a function $\phi_0^{(r)}(x; \varepsilon)$,

$$\phi(x; \varepsilon) = \phi_0(x; \varepsilon) + \delta_1^{(r)}(\varepsilon) \phi_0^{(r)}(x; \varepsilon),$$

and proceed in the same way as for $\phi(x; \varepsilon)$ in order to construct an approximation for $\phi_0^{(r)}(x; \varepsilon)$. Let $\phi_1(x; \varepsilon)$ be an approximation of $\phi_0^{(r)}(x; \varepsilon)$ which is uniformly valid for $0 \leq x \leq R$, then we obtain the expression

$$\phi(x; \varepsilon) = \phi_0(x; \varepsilon) + \delta_1^{(r)}(\varepsilon) \phi_1(x; \varepsilon) + \delta_2^{(r)} \phi_1^{(r)}(x; \varepsilon).$$

This procedure can be continued indefinitely.

Remark When in (3.19) $m = 1$, the results of this section provide a justification of the matching procedure frequently applied in boundary layer problems. For $m = 2, 3, \dots$ this study represents a justification of the so-called multiple boundary layer theory.

Example 3.3 We analyse the behaviour of the function $\phi(x;\varepsilon)$, defined in $G_\varepsilon = \{x, \varepsilon: 0 < x, 0 < \varepsilon \leq \varepsilon^*\}$,

$$\phi(x;\varepsilon) = (x^2 + x\varepsilon - 1) + (2 + x/\varepsilon)e^{-x/\varepsilon} + e^{-2x/\varepsilon^2} + e^{-(x+1)/\varepsilon}.$$

The reader will observe that every substitution of the form $x = \xi_\nu \delta_\nu(\varepsilon)$ yields $\phi(x;\varepsilon) \underset{\text{as}}{=} \delta_\nu^*(\varepsilon) \underset{\text{as}}{=} \delta^*(\varepsilon) \underset{\text{as}}{=} 1$.

Generally, limit functions satisfying (3.13) will be called equivalent, if there exists an order function $\delta^*(\varepsilon)$ such that $\delta_\nu^* \underset{\text{as}}{=} \delta^*$ for all transformations of type $x = \xi_\nu \delta_\nu(\varepsilon)$. In such a case the representation of the matching principle and the construction of a composite expansion can be simplified, as we will see in the present example.

We observe that

$$\lim_{\varepsilon \rightarrow 0} [\phi(x;\varepsilon) - \omega(x)] = 0, \quad \omega(x) = x^2 - 1 \quad \text{for } x > 0,$$

and that the limit

$$\lim_{\xi_\nu} [\phi(x;\varepsilon) - \psi_\nu(\xi_\nu)] = 0, \quad x = \xi_\nu \varepsilon^\nu,$$

has as corresponding limit functions

$$\psi_\nu(\xi_\nu) = -1 \quad (0 < \nu < 1),$$

$$\psi_1(\xi_1) = -1 + (2 + \xi_1)e^{-\xi_1} \quad (\nu = 1),$$

$$\psi_\nu(\xi_\nu) = 1 \quad (1 < \nu < 2),$$

$$\psi_2(\xi_2) = 1 + e^{-2\xi_2} \quad (\nu = 2),$$

$$\psi_\nu(\xi_\nu) = 2 \quad (\nu > 2).$$

Formulae (3.18) and (3.21) transform into

$$(3.22) \quad \lim_{\xi_n \rightarrow \infty} \psi_n(\xi_n) = \lim_{\xi_{n-1} \rightarrow 0} \psi_{n-1}(\xi_{n-1}),$$

$$(3.23) \quad \phi_0(x;\varepsilon) = \omega(x) - \omega(0) + \sum_{n=1}^m \psi_n\left(\frac{x}{\delta_n}\right) - \sum_{n=1}^{m-1} \psi_n(0).$$

For this example (3.23) becomes

$$\phi_0(x;\varepsilon) = x^2 - 1 + (2+\xi_1)e^{-\xi_1} + e^{-2\xi_2}.$$

3.7 A SPECIAL CASE OF NON-UNIFORM CONVERGENCE OF FUNCTIONS OF TWO VARIABLES

We assume that the function $\phi(x,y;\varepsilon)$, defined in $G_\varepsilon = \{x,y,\varepsilon: 0 \leq x \leq R, -R \leq y \leq R, 0 < \varepsilon \leq \varepsilon^*\}$, is continuous in x , y and ε , and that $\omega(x,y)$, defined in $G = \{x,y: 0 < x \leq R, -R \leq y \leq R\}$ is continuous in x and y . Moreover, it is assumed that

$$(3.24) \quad \lim_{\varepsilon \rightarrow 0} [\phi(x,y;\varepsilon) - \omega(x,y)] = 0$$

converges non-uniformly in G and uniformly in $\bar{G} - G_A$, where

$G_A = \{x,y: 0 \leq x \leq A, -R \leq y \leq R\}$ and A is an arbitrary positive number.

Let s be a vector with components x and y , $s = (x,y)$, then (3.24) changes into

$$\lim_{\varepsilon \rightarrow 0} [\phi(s;\varepsilon) - \omega(s)] = 0.$$

In a similar manner as in section 3.1 we define functions $\varepsilon_0(q,s)$ satisfying the conditions

- a. $|\phi(s;\varepsilon) - \omega(s)| \leq q$ for $0 < \varepsilon \leq \varepsilon_0(q,s)$ and $0 < x \leq R, -R \leq y \leq R$,
- b. $\varepsilon_0(q,s)$ is continuous in q , x , and y ,
- c. $\varepsilon_0(q,s)$ is monotonic increasing in q and x ,
- d. $\lim_{q \rightarrow 0} \varepsilon_0(q,s) = 0$ and $\lim_{s \rightarrow (0,y_1)} \varepsilon_0(q,s) = 0$, $-R \leq y_1 \leq R$,
- e. let $x = x(\lambda)$, $y = y(\lambda)$ be an arbitrary path along which a point $(x(0), y(0)) = (0, y_1)$ is approached, and let x be monotonic non-de-

creasing for $0 \leq \lambda \leq \lambda^*$. Then for an arbitrary small $\lambda_0 > 0$ values λ_k exist with $0 < \lambda_k < \lambda_0$ such that $|\phi(s(\lambda_k), \varepsilon) - \omega(s(\lambda_k))| > q$ for $\varepsilon = \varepsilon_0(q, s(\lambda_k)) + \sigma$, where σ is a positive arbitrarily small number.

Lemma 3.2 Let $\varepsilon_0(q, s)$ be a function with properties a, ..., e, then there exist functions $\bar{\varepsilon}_0(x)$ such that

$$\lim_{s \rightarrow (0, y_1)} \frac{\bar{\varepsilon}_0(s)}{\varepsilon_0(q, s)} = 0, \quad 0 < q \leq q_0, \quad -R \leq y_1 \leq R,$$

independently of the path chosen in the domain $0 \leq x \leq R, \quad -R \leq y \leq R$.

Proof For $0 < q_2 < q_1 \leq q_0$ we may have that

$$\lim_{s \rightarrow (0, y_1)} \frac{\varepsilon_0(q_2, s)}{\varepsilon_0(q_1, s)} \neq 0, \quad y_1 \in \Gamma_1$$

or

$$\lim_{s \rightarrow (0, y_2)} \frac{\varepsilon_0(q_2, s)}{\varepsilon_0(q_1, s)} = 0, \quad y_2 \in \Gamma_2, \quad \Gamma_1 + \Gamma_2 = [-R, R].$$

It appears that the function $\bar{\varepsilon}_0(s) = r_1(s)\varepsilon_0(r_2(s), s)$ satisfies the condition of the lemma. The functions $r_1(s)$ and $r_2(s)$ are positive and continuous, $r_2(s) \leq q_0$ for all s ,

$$\lim_{s \rightarrow (0, y_1)} r_1(s) = 0 \quad \text{for } y_1 \in \Gamma_1$$

and

$$\lim_{s \rightarrow (0, y_2)} r_2(s) = 0 \quad \text{for } y_2 \in \Gamma_2.$$

Theorem 3.4 Let $\phi(s; \varepsilon)$ be a continuous function, defined in $G_\varepsilon = \{s, \varepsilon: 0 < x < R, -R < y < R, 0 < \varepsilon < \varepsilon^*\}$ and let the limit

$$\lim_{\varepsilon \rightarrow 0} [\phi(s; \varepsilon) - \omega(s)] = 0$$

hold uniformly in $\bar{G} - G_A$, where $G_A = \{x, y: 0 < x < A, -R < y < R\}$ and A is an arbitrary

bitrary positive number. Then there exist functions $\varepsilon = \bar{\varepsilon}_0(s)$, positive, continuous in x and y , monotonic increasing in x with $\lim_{s \rightarrow (0, y_1)} \bar{\varepsilon}_0(s) = 0$, such that the limit

$$(3.25) \quad \lim_{\varepsilon \rightarrow 0} [\phi(s; \varepsilon) - \omega(s)] = 0$$

is uniformly valid in $P_\varepsilon = \{s, \varepsilon: 0 < x < R, -R < y < R, 0 < \varepsilon < \bar{\varepsilon}_0(s)\}$.

Proof The main lines of the proof of theorem 3.1 are followed. The functions $\bar{\varepsilon}_0(s)$ are determined with the aid of lemma 3.2. We consider an arbitrary path in the domain P_ε , which ends in a point $(s, \varepsilon) = (s_1, 0)$, where $s_1 = (x_1, y_1)$, $0 \leq x_1 \leq R$, $-R \leq y_1 \leq R$. On such a path a sequence of points $Q_m(\varepsilon_m, s_1 + \sigma_m)$ is defined which has a limit of type $\lim_{m \rightarrow \infty} \varepsilon_m = 0$ and $\lim_{m \rightarrow \infty} \sigma_m = (0, 0)$. Moreover, there exists a sequence q_n with $\lim_{n \rightarrow \infty} q_n = 0$. For any n a domain $\Omega_n = \{x, y: 0 < x < g_n(y), -R < y < R\}$ exists in which $\bar{\varepsilon}_0(s) \leq \varepsilon_0(q_n, s)$.

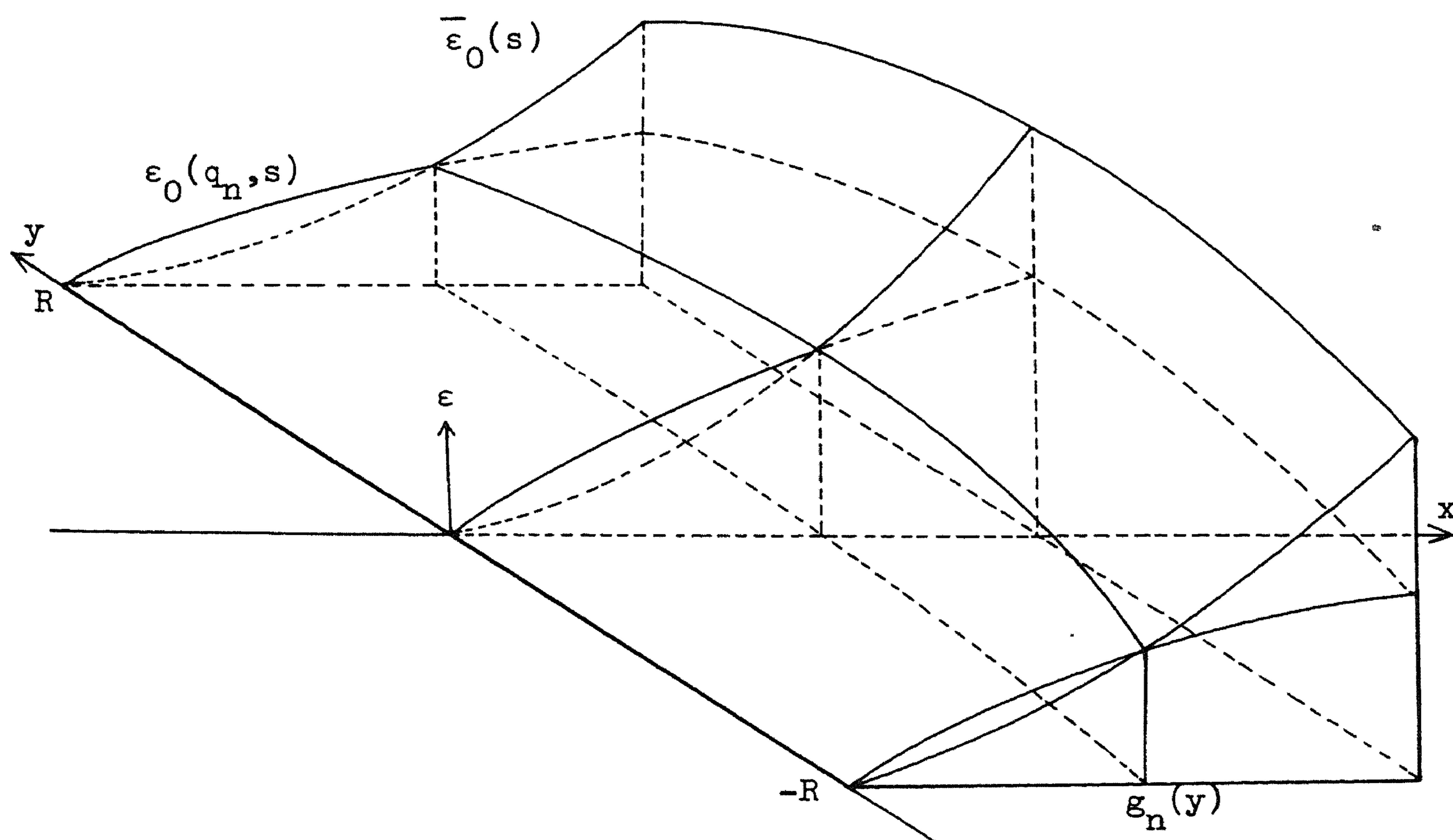

fig. 3.1

Let $\Gamma_n = \{x, y: x = g_n(y)\}$ be the boundary of Ω_n , then we define the numbers

$$\bar{\varepsilon}_{0n} = \min_{\Gamma_n} \bar{\varepsilon}_0(s), \quad \varepsilon_{0n} = \min_{\Gamma_n} \varepsilon_0(q_n, s), \quad (\bar{\varepsilon}_{0n} \leq \varepsilon_{0n}).$$

The number m_n^* is chosen such that $\varepsilon_m \leq \bar{\varepsilon}_{0n}$ for $m \geq m_n^*$. For these values of m we may have the following

$$\varepsilon_m \leq \bar{\varepsilon}_0(s_1 + \sigma_m) \leq \varepsilon_0(q_n, s_1 + \sigma_m), \quad \text{if } s_1 + \sigma_m \in \Omega_n,$$

or

$$\varepsilon_m \leq \bar{\varepsilon}_{0n} \leq \varepsilon_{0n} \leq \varepsilon_0(q_n, s_1 + \sigma_m), \quad \text{if } s_1 + \sigma_m \notin \Omega_n.$$

In both cases is $\varepsilon_m \leq \varepsilon_0(q_n, s_1 + \sigma_m)$ for $m \geq m_n^*$, which agrees with definition 3.1 of uniform convergence.

We assume that $x = \delta_0^{(q)}(y, \varepsilon)$ is the inverse function of $\varepsilon = \varepsilon_0(q, x, y)$ and that $x = \bar{\delta}_0(y, \varepsilon)$ is the inverse function of $\varepsilon = \bar{\varepsilon}_0(x, y)$. These inverse functions belong to sets of order functions having the following properties:

- a. $\lim_{\varepsilon \rightarrow 0} \delta_0^{(q)}(y, \varepsilon) = 0, \quad \lim_{\varepsilon \rightarrow 0} \bar{\delta}_0(y, \varepsilon) = 0,$
- b. $\delta_0^{(q_1)}(y, \varepsilon) \underset{\text{as}}{<} \delta_0^{(q_2)}(y, \varepsilon) \quad \text{for } 0 < q_2 < q_1 \leq q_0,$
- c. $\delta_0^{(q)}(y, \varepsilon) \underset{\text{as}}{<<} \bar{\delta}_0(y, \varepsilon) \quad \text{for all } 0 < q \leq q_0.$

Thus we may say that (3.25) holds uniformly for $\xi \bar{\delta}_0(y, \varepsilon) \leq x \leq R$, $-R \leq y \leq R$, where ξ is some positive constant and $\delta_0^{(q)}(y, \varepsilon) \underset{\text{as}}{<<} \bar{\delta}_0(y, \varepsilon) \underset{\text{as}}{<} 1$ for all $0 < q \leq q_0$.

Let the function $\psi_\nu(\xi, y)$ satisfy the limit

$$(3.26) \quad \lim_{\xi_\nu} \left[\frac{\phi(s; \varepsilon)}{\delta_\nu^*(\varepsilon)} - \psi_\nu(\xi_\nu, y) \right] = 0, \quad x = \xi_\nu \delta_\nu(y, \varepsilon), \quad \delta_\nu \underset{\text{as}}{<} 1.$$

Definition 3.3 The limit of the singular function $\phi(x,y;\varepsilon)$ as given in this section exists, if there exists a non-trivial function $\psi_\nu(\xi_\nu, y)$ and an order function $\delta_\nu^*(\varepsilon)$, such that (3.26) holds for some ξ_ν .

Using the method of constructing a uniformly valid approximation of $\phi(s;\varepsilon)$, as applied in the preceding sections, we obtain

$$\phi(s;\varepsilon) = \phi_0(s;\varepsilon) + \delta_1^{(r)}(\varepsilon)\phi_0^{(r)}(s;\varepsilon),$$

where $\phi_0(s;\varepsilon)$ has a same composition of terms as in (3.20), except that we now have terms of the type $\omega(x,y)$, $\psi_n(\frac{x}{\delta_n(y,\varepsilon)}, y)$ and $\psi_{n_\nu}(\frac{x}{\delta_{n_\nu}(y,\varepsilon)}, y)$.

In most applied mathematical problems the order functions $\delta_n(y,\varepsilon)$ and $\delta_{n_\nu}(y,\varepsilon)$ are independent of y . An exception in this respect is contained in Mahony [22], who introduced a transformation of the type $xk(y) = \delta_\nu\varepsilon + O(x)$, which is an indication for the direction of the greatest rate of change in the boundary layer portion of the approximation.

Example 3.4 We observe that for the function

$$\phi(x,y;\varepsilon) = (1+y^2+x/\varepsilon) \exp\left(\frac{-x}{(y^4+y^2+\varepsilon)\varepsilon}\right) + 1 + x^2$$

the limit

$$(3.27) \quad \lim_{\varepsilon \rightarrow 0} [\phi(x,y;\varepsilon) - \omega(x,y)] = 0, \quad \omega(x,y) = 1 + x^2,$$

holds uniformly in the greater part of the domain $0 \leq x \leq R$, $-R \leq y \leq R$. However, for $x = 0$ we have $\phi(0,y;\varepsilon) = 2 + y^2$, so the function $\phi(x,y;\varepsilon)$ will change suddenly near $x = 0$ for small values of ε ((3.27) converges non-uniformly near $x = 0$).

Applying the extension theorem we obtain a uniform convergence of (3.27) for $x = \xi_\nu \delta_\nu$, $0 \leq |y| \leq R$, where $\delta_0^{(q)} \ll_{as} \delta_\nu < 1$, $\delta_0^{(q)} =_{as} (y^2+\varepsilon)\varepsilon$. Further, the limit function $\psi_1(\xi_1, y)$ is introduced by

$$(3.28) \quad \lim_{\xi_1} [\phi(x,y;\varepsilon) - \psi_1(\xi_1, y)] = 0, \quad x = \xi_1 \delta_1(y,\varepsilon), \quad \delta_1(y,\varepsilon) =_{as} \delta_0^{(q)}(y,\varepsilon),$$

so that $\psi_1(\xi_1, y) = \{1+y^2(1+\xi_1)\} \exp\left(\frac{-\xi_1}{y^2+1}\right) + 1$.

The limit (3.28) holds uniformly for $\xi_1 \geq 0$. Finally, the uniformly valid approximation appears to have the form

$$\phi_0(x, y; \varepsilon) = (1+x^2) + \{1+y^2(1+\xi_1)\} \exp\left(\frac{-\xi_1}{y^2+1}\right), \quad \xi_1 = \frac{x}{(y^2+\varepsilon)\varepsilon}.$$

CHAPTER IV APPROXIMATIONS OF IMPLICITLY DEFINED FUNCTIONS

4.1 INTRODUCTORY REMARKS

In chapter 3 we have analyzed the behaviour of a singular function and have obtained results concerning the foundations of the matching principle and the construction of composite approximations. These results have been derived for explicitly given functions. However, the purpose of the matching principle is to use it for implicitly defined functions in order to determine unknown constants and to construct uniformly valid expansions. Nevertheless, from the preceding chapters we have obtained a complete insight into the structure of singular functions.

Our aim is to apply this knowledge in singular perturbation theory, we shall consider both ordinary and elliptic differential equations with a small parameter contained in the highest derivatives. Here a new aspect arises, namely that we have to prove the uniform validity of the composite approximation of an implicitly defined function. This leads to the necessity of providing an estimate of the accuracy of the approximation. By means of the maximum principle some theorems concerning this type of estimates are proved. Erdelyi [9] and O'Malley [23] also give such theorems for the case of ordinary differential equations. Their proofs are based on the method of successive approximations. It will appear that by our approach the accuracy of more complicated linear problems can also be determined (see chapter 6).

In this chapter we compare the formal singular perturbation procedure with the results obtained for the exact solution which we are supposed to be explicitly given (chapter 3). We will show that for certain classes of differential equations the solution of the limit equation equals the limit of the exact solution as $\epsilon \rightarrow 0$ (theorems 4.4, 4.7 and 4.10).

4.2 THE INITIAL VALUE PROBLEM FOR AN ORDINARY SECOND ORDER DIFFERENTIAL EQUATION

We consider the function $\phi(x;\epsilon)$, defined on the interval $0 \leq x \leq 1$, satisfying the differential equation

$$(4.1) \quad L_\varepsilon \phi \equiv \varepsilon L_2 \phi + L_1 \phi = h(x), \quad 0 < \varepsilon \ll 1,$$

where L_2 and L_1 denote the linear differential operators

$$L_2 \equiv \frac{d^2}{dx^2} + a_1(x) \frac{d}{dx} + a_0(x),$$

$$L_1 \equiv b_1(x) \frac{d}{dx} + b_0(x).$$

The coefficients a_0 , a_1 , b_0 , b_1 and h are three times continuously differentiable. Furthermore, we assume that $\varepsilon a_0(x) + b_0(x) \leq 0$ and $b_1(x) > 0$ on the complete interval. The function $\phi(x, \varepsilon)$ has the initial values

$$(4.2a) \quad \phi(0; \varepsilon) = p(\varepsilon) = p_0, \quad p_0 \neq 0,$$

$$(4.2b) \quad \phi'(0; \varepsilon) = q(\varepsilon) = q_{-1} \varepsilon^{-1}.$$

This problem can be solved with the usual singular perturbation method as we shall see later. However, an asymptotic solution obtained that way only holds formally. In order to prove the consistency of this asymptotic solution (with the exact solution) we have to use other concepts. It appears that the maximum principle provides a starting-point for such a proof.

We formulate the maximum principle for the above mentioned problem as follows:

If $L_\varepsilon V(x; \varepsilon) \geq 0$ for $a < x < b$ and $V(x; \varepsilon)$ takes a maximum value M (≥ 0) at $x = x_1$ ($a < x_1 < b$), then $V(x; \varepsilon) = M$. When $\varepsilon a_0(x) + b_0(x) \neq 0$, M is zero.

For several applications of the maximum principle the reader is referred to [30]. In the following lemma the functions $\psi(x; \varepsilon)$, so-called barrier-functions, are introduced.

Lemma 4.1 Let the twice to x continuously differentiable functions $\phi(x; \varepsilon)$ and $\psi(x; \varepsilon)$ satisfy within $0 < x < 1$ the relation $|L_\varepsilon \phi| \leq L_\varepsilon \psi$ with L_ε as in (4.1), and let $|\phi(0; \varepsilon)| \leq \psi(0; \varepsilon)$, $|\phi_x(0; \varepsilon)| \leq \psi_x(0; \varepsilon)$, then $|\phi(x; \varepsilon)| \leq \psi(x; \varepsilon)$ within $0 \leq x \leq 1$.

Proof Considering the function $V(x;\varepsilon) = \psi(x;\varepsilon) - \phi(x;\varepsilon)$ we notice that $V(0;\varepsilon) \geq 0$, $V_x(0;\varepsilon) \geq 0$, and $L_\varepsilon V \geq 0$ for $0 < x < 1$.

First we will prove that

$$(4.3) \quad V(x;\varepsilon) = \psi(x;\varepsilon) - \phi(x;\varepsilon) \geq 0, \quad 0 \leq x \leq 1.$$

Taking an arbitrary point x_0 ($0 < x_0 < 1$) we observe that according to the maximum principle the function $V(x;\varepsilon)$ cannot have a positive maximum on the open interval $0 < x < x_0$. So the maximum must occur at either $x = 0$ or at $x = x_0$. Since $V_x(0;\varepsilon) \geq 0$ we conclude that the maximum can only occur at $x = x_0$. Thus $V(x_0;\varepsilon) \geq V(0;\varepsilon) \geq 0$ for any $0 < x_0 < 1$. Similarly it is proved that for the function $W(x;\varepsilon) = \psi(x;\varepsilon) + \phi(x;\varepsilon)$ the following relation holds

$$(4.4) \quad W(x;\varepsilon) = \psi(x;\varepsilon) + \phi(x;\varepsilon) \geq 0, \quad 0 \leq x \leq 1.$$

Inequalities (4.3) and (4.4) complete the proof of lemma 4.1.

The barrier-function $\psi(x;\varepsilon)$ gives a bound for the absolute values of $\phi(x;\varepsilon)$ on the interval $0 \leq x \leq 1$.

The procedure of estimating the remainder term of an approximation of $\phi(x;\varepsilon)$ satisfying (4.1) and (4.2) consists of the construction of an appropriate barrier-function, which is achieved in the following theorem.

Theorem 4.1 Let $Z(x;\varepsilon)$, defined on the interval $0 \leq x \leq 1$, satisfy the differential equation

$$L_\varepsilon Z(x;\varepsilon) = h(x;\varepsilon)$$

with L_ε as in (4.1), and have the initial values $Z(0;\varepsilon)$ and $Z_x(0;\varepsilon)$.

If $|Z(0;\varepsilon)| \leq m\varepsilon^{\mu_1}$, $|Z_x(0;\varepsilon)| \leq m\varepsilon^{\mu_2}$ and $|h(x;\varepsilon)| \leq m\varepsilon^{\mu_3}$ for $0 \leq x \leq 1$,

then a real number K independent of x and ε exists such that

$$|Z(x;\varepsilon)| \leq Km\varepsilon^\alpha, \quad \alpha = \min(\mu_1, \mu_2, \mu_3), \quad 0 \leq x \leq 1.$$

Proof Let s be a number that satisfies the inequalities $s > 1$,

$\varepsilon a_1(x) + b_1(x) \geq 1/s$ and $\varepsilon a_0(x) + b_0(x) \geq -s$, then $\psi(x;\varepsilon) = m\varepsilon^\alpha \exp(2s^2x)$

is a barrier-function for $Z(x;\varepsilon)$. It turns out that $\psi(0;\varepsilon) = m\varepsilon^\alpha \geq m\varepsilon^{\mu_1}$,
 $\psi_x(0;\varepsilon) = 2ms^2\varepsilon^\alpha \geq m\varepsilon^{\mu_2}$ and
 $L_\varepsilon \psi(x;\varepsilon) \geq (4s^4\varepsilon + 2/3s^2 - s)m\varepsilon^\alpha \exp(2s^2x) \geq m\varepsilon^\alpha \geq m\varepsilon^{\mu_3} \geq |L_\varepsilon Z(x;\varepsilon)|$. Applica-
tion of lemma 4.1 leads to the estimate $|Z(x;\varepsilon)| \leq Km\varepsilon^\alpha$.

This theorem can be interpreted in the following way:
if $Z(0;\varepsilon) = O(\varepsilon^{\mu_1})$, $Z_x(0;\varepsilon) = O(\varepsilon^{\mu_2})$ and $L_\varepsilon Z(x;\varepsilon) = O(\varepsilon^{\mu_3})$ on the interval
 $0 \leq x \leq 1$, then $Z(x;\varepsilon) = O(\varepsilon^{\min(\mu_1, \mu_2, \mu_3)})$ on this interval.
Let $\phi_{\text{app}}(x;\varepsilon)$ represent an approximation of a function $\phi(x;\varepsilon)$. Then substi-
tution of $\phi(x;\varepsilon) = \phi_{\text{app}}(x;\varepsilon) + Z(x;\varepsilon)$ in (4.1) leads to the inhomogeneous
equation $L_\varepsilon Z(x;\varepsilon) = -L_\varepsilon \phi_{\text{app}} + h(x)$. Further, estimation of the right-hand
side of this equation and the initial values of $Z(x;\varepsilon)$ yields the neces-
sary information to apply theorem 4.1.

Now we pay attention to the construction of an approximation of $\phi(x;\varepsilon)$
satisfying (4.1) and (4.2). As we have mentioned before, the singular per-
turbation method is usually applied to solve such problems. We will give an
outline of the method and a proof of the validity of the approximation
which is obtained in this way. Let

$$(4.5) \quad \phi(x;\varepsilon) = U_0(x) + Z_u(x;\varepsilon)$$

where $U_0(x)$ satisfies the reduced equation of (4.1)

$$L_1 U_0 = h(x),$$

$$U_0(x) = C_0 + \int_0^x \exp\left\{-\int_{\bar{x}}^x \frac{b_0(\hat{x})}{b_1(\hat{x})} d\hat{x}\right\} \frac{h(\bar{x}) - C_0 b_0(\bar{x})}{b_1(\bar{x})} d\bar{x}.$$

We observe that $U_0(x)$ generally does not satisfy both initial conditions,
so approximation (4.5) cannot be valid near $x = 0$. The local coordinate ξ
is introduced

$$(4.6) \quad x = \xi\varepsilon.$$

Substitution of (4.6) in L_ε leads to the operator expansion

$$(4.7) \quad \epsilon L_\epsilon \equiv M_0 + \epsilon M_1 + \epsilon^2 \bar{M}_2,$$

$$M_0 \equiv \frac{d^2}{d\xi^2} + b_1(0) \frac{d}{d\xi},$$

$$M_1 \equiv (a_1(0) + b_1'(0)) \frac{d}{d\xi} + b_0(0).$$

\bar{M}_2 is a first order differential operator containing the truncated terms of the operator expansion. We suppose that for $0 \leq x \leq K\epsilon$ with K an arbitrarily large positive number independent of ϵ another approximation will hold

$$(4.8) \quad \phi(x; \epsilon) = V_0(\xi) + \epsilon V_1(\xi) + Z_V(x; \epsilon), \quad x = \xi\epsilon,$$

where $V_0(\xi)$ and $V_1(\xi)$ satisfy the equations

$$(4.9) \quad M_0 V_0 = 0, \quad M_0 V_1 = M_1 V_0 + h(0),$$

and have the initial values

$$\begin{aligned} V_0(0) &= p_0, & V_1(0) &= 0, \\ \left. \frac{dV_0}{d\xi} \right|_{\xi=0} &= q_{-1}, & \left. \frac{dV_1}{d\xi} \right|_{\xi=0} &= 0. \end{aligned}$$

For $V_0(\xi)$ we have

$$(4.10) \quad V_0(\xi) = \frac{-q_{-1}}{b_1(0)} e^{-b_1(0)\xi} + \left(p_0 + \frac{q_{-1}}{b_1(0)} \right),$$

a similar expression holds for $V_1(\xi)$.

Through the matching condition

$$\lim_{\xi \rightarrow \infty} V_0(\xi) = \lim_{x \rightarrow 0} U_0(x)$$

the value of C_0 is determined: $C_0 = p_0 + q_{-1}/b_1(0)$. For the following theorem it is assumed that $S_0(\xi)$ and $S_1(\xi)$ represent the non-exponential terms

of $V_0(\xi)$ and $V_1(\xi)$. In this theorem the validity of a (formal) composite solution is demonstrated.

Theorem 4.3 Let the function $\phi(x;\epsilon)$, defined on the interval $0 \leq x \leq 1$, satisfy the differential equation $L_\epsilon \phi(x;\epsilon) = h(x)$ and have the initial values

$$\phi(0;\epsilon) = p(\epsilon) = p_0, \quad p_0 \neq 0$$

$$\phi_x(0;\epsilon) = q(\epsilon) = q_{-1}\epsilon^{-1}.$$

It is then possible to approximate the function $\phi(x;\epsilon)$ by

$$\phi(x;\epsilon) = U_0(x) + \{V_0(\xi) - S_0(\xi)\} + Z_0(x;\epsilon), \quad x = \xi\epsilon,$$

where $Z_0(x;\epsilon) = o(\epsilon)$ for $0 \leq x \leq 1$.

Proof

$$(4.11) \quad \phi(x;\epsilon) = U_0(x) + \{V_0(\xi) - S_0(\xi)\} + \{V_1(\xi) - S_1(\xi)\}\epsilon + \bar{Z}_0(x;\epsilon),$$

$\bar{Z}_0(x;\epsilon)$ is a uniformly bounded function, because of the boundedness of ϕ , U_0 , $V_0 - S_0$ and $V_1 - S_1$. Substitution of (4.11) in (4.1) yields

$$(4.12) \quad L\bar{Z}_0(x;\epsilon) = -\epsilon K_0(x;\epsilon),$$

$$K_0(x;\epsilon) = L_2 U_0 + M_1(V_1 - S_1) + \bar{M}_2(V_0 - S_0) + \epsilon \bar{M}_2(V_1 - S_1).$$

From the boundedness of $K_0(x;\epsilon)$ it follows that $L_\epsilon \bar{Z}_0 = o(\epsilon)$ for $0 \leq x \leq 1$. The initial values of \bar{Z}_0 are $\bar{Z}_0(0;\epsilon) = o(\epsilon^2)$ and $\bar{Z}_{0x}(0;\epsilon) = o(\epsilon)$. Applying theorem 4.1 we conclude that $\bar{Z}_0(x;\epsilon) = o(\epsilon)$ on the interval $0 \leq x \leq 1$.

Finally, it follows from the boundedness of $V_1 - S_1$ that

$$\phi(x;\epsilon) = U_0(x) + V_0(x/\epsilon) - S_0(x/\epsilon) + Z_0(x;\epsilon), \quad \text{where } Z_0(x;\epsilon) = o(\epsilon).$$

The foregoing analysis leads to the solution of the singular perturbation of the initial value problem, as established in the literature. This

method contains some more or less arbitrarily chosen steps such as the way of introducing the boundary layer coordinate $\xi = x/\varepsilon$ and the matching procedure.

Our task is to show the deeper meaning of these seemingly arbitrary steps. Inspired by the results, which we obtained for explicitly given functions, we came to the following procedure of constructing a formal approximation.

- a. All degenerations of the differential operator L_ε are taken into consideration. Substitution of $x = \xi_\nu \delta_\nu(\varepsilon)$ into $L_\varepsilon \phi(x; \varepsilon) = h(x)$ changes the equation into

$$(4.13) \quad L_\varepsilon \phi \equiv \varepsilon \delta_\nu^{-2} \frac{d^2 \phi}{d\xi_\nu^2} + \varepsilon \delta_\nu^{-1} a_1(\xi_\nu \delta_\nu) \frac{d\phi}{d\xi_\nu} + \varepsilon a_0(\xi_\nu \delta_\nu) \phi + \\ + \delta_\nu^{-1} b_1(\xi_\nu \delta_\nu) \frac{d\phi}{d\xi_\nu} + b_0(\xi_\nu \delta_\nu) \phi = h(\xi_\nu \delta_\nu).$$

Both sides of (4.13) are multiplied by an order function $\bar{\delta}_\nu^*(\varepsilon)$ such that $\lim_{\varepsilon \rightarrow 0} \bar{\delta}_\nu^* L_\varepsilon = L_0^{(\nu)}$, where $L_0^{(\nu)}$ denotes a differential operator of the first or second order with coefficients of order $O(1)$.

- b. A formal limit function is defined as follows.

Definition 4.1 We say that for transformation $x = \xi_\nu \delta_\nu(\varepsilon)$ a formal limit function $\bar{\psi}_\nu(\xi_\nu)$ exists, if there exists a non-trivial solution of

$$(4.14) \quad L_0^{(\nu)} \bar{\psi}_\nu(\xi_\nu) = \bar{h}_\nu(\xi_\nu), \quad \bar{h}_\nu(\xi_\nu) = \lim_{\varepsilon \rightarrow 0} \bar{\delta}_\nu^*(\varepsilon) h(\xi_\nu \delta_\nu)$$

on some interval of ξ_ν .

In this way the formal limit function is determined with the exception of the integration constants.

- c. For two paths sufficiently close to each other the corresponding formal limit functions have to match. Let $x = \xi_\nu \delta_\nu$ and $x = \xi_{\nu+\Delta} \delta_{\nu+\Delta}$ ($\delta_{\nu+\Delta} \ll \delta_\nu$ as δ_ν). Then the order function $\bar{\delta}_\nu \ll 1$ exists such that the

following relation holds

$$(4.15) \quad \lim_{\xi_\mu} \left[\frac{\delta_\nu^*}{\delta_\mu^*} \bar{\psi}_\nu \left(\frac{\delta_\mu}{\delta_\nu} \xi_\mu \right) \right] = \lim_{\xi_\mu} \left[\frac{\delta_{\nu+\Delta}^*}{\delta_\mu^*} \bar{\psi}_{\nu+\Delta} \left(\frac{\delta_\mu}{\delta_{\nu+\Delta}} \xi_\mu \right) \right],$$

$$x = \xi_\mu \delta_\mu(\varepsilon), \quad \delta_{\nu+\Delta} \ll \delta_\mu \ll \delta_\nu,$$

if $\bar{\delta}_\nu \ll \delta_{\nu+\Delta} / \delta_\nu < 1$.

At this stage the order functions δ_ν^* , $\delta_{\nu+\Delta}^*$ and δ_μ^* are unknown. Condition (4.15) yields relations that must exist between the integration constants of the formal limit functions and between the order functions δ_ν^* and $\delta_{\nu+\Delta}^*$.

d. One of the formal limit functions satisfies the initial conditions,

$$(4.16) \quad \bar{\psi}_b(0) = p_0, \quad \left. \frac{d\bar{\psi}_b}{d\xi_b} \right|_{\xi_b=0} = q_{-1}.$$

By these conditions the formal limit functions $\bar{\psi}_\nu(\xi_\nu)$ and the order functions δ_ν^* are determined uniquely.

Let $x = \xi_\nu \delta_\nu(\varepsilon)$ be a path in the domain $0 \leq x \leq 1$. For $\delta_\nu \approx 1$ we have the formal limit function $\bar{\omega}(x)$ satisfying $L_1 \bar{\omega}(x) = h(x)$,

$$(4.17) \quad \bar{\omega}(x) = C_0 + \int_0^x \exp\left\{-\int_{\bar{x}}^x \frac{b_0(\bar{x})}{b_1(\bar{x})} d\bar{x}\right\} \cdot \frac{h(\bar{x}) - C_0 b_0(\bar{x})}{b_1(\bar{x})} d\bar{x}.$$

For $\delta_\nu \ll 1$ the reader is referred to table I where we summarize the results of a, b, c and d for the initial value problem.

e. Finally a formal uniformly valid asymptotic approximation is composed of the formal limit functions:

$$(4.18) \quad \bar{\phi}_0(x; \varepsilon) = \sum_{n=0}^m \bar{\psi}_n(x/\delta_n) \delta_n^* - \sum_{n=0}^{m-1} \bar{\psi}_{\nu_{n+1}}(x/\delta_{\nu_{n+1}}) \delta_{\nu_{n+1}}^* \quad (\bar{\psi}_0 = \bar{\omega}).$$

This composition of terms is suggested by the results we obtained for explicitly given functions (see formula (3.20)).

$\{\bar{\psi}_n; n=0, m\}$ denotes the smallest subset of limit functions from which

Table I

	a		b	c		d	
δ_v	$\overline{\delta}_v^*$	$L_0^{(v)}$	$\overline{\psi}_v$	matching relations		δ_v^*	integration constants
$\delta_{0as} = 1$	1	$b_1(x) \frac{d}{dx} + b_0(x)$	$\overline{\psi}_0 = \overline{\omega}(x)$	$\delta_0^* = \delta_{v_1}^*$ $\delta_{v_1}^* = \delta_C^*$ $\delta_{v_1}^* = \delta_1^*$ $\delta_1^* = \delta_{v_2}^*$ $\delta_{v_2}^* = \delta_F^*$	$C_0 = C_{v_1}$	1	$C_0 = E_1$
$\epsilon \ll \delta_{as} \ll 1$	δ_{v_1}	$b_1(0) \frac{d}{d\xi_{v_1}}$	$\overline{\psi}_{v_1} = C_{v_1}$		$C_{v_1} = C$	1	$C_{v_1} = E_1$
$\delta_{1as} = \epsilon$	δ_1	$\frac{d^2}{d\xi_1^2} + b_1(0) \frac{d}{d\xi_1}$	$\overline{\psi}_1 = D_1 e^{-b_1(0)\xi_1 + E_1}$		$C_{v_1} = E_1$	1	$D_1 = -q_{-1}/b_1(0)$ $E_1 = p_0 + q_{-1}/b_1(0)$
$\delta_{v_2as} \ll \delta_1$	$\epsilon^{-1} \delta_{v_2}^2$	$\frac{d^2}{d\xi_{v_2}^2}$	$\psi_{v_2} = G_{v_2} \xi_{v_2} + F_{v_2}$		$D_1 + E_1 = F_{v_2}$ $F_{v_2} = F, *$ $G_{v_2} = 0$	1	$F_{v_2} = D_1 + E_1$ $G_{v_2} = 0$

) Another possibility is $G_{v_2} = G, F_{v_2} = 0, \delta_{v_2}^ = \delta_G^* \delta_{v_2}$. However, this is excluded, because $D_1 + E_1 = p_0 \neq 0$.

all the other limit functions can be derived (by substitution of the proper local coordinates and by letting ε tend to zero).

The order function $\delta_n(\varepsilon)$ determines the corresponding paths $x = \xi_n \delta_n(\varepsilon)$. The set $\{\bar{\psi}_{\nu_{n+1}}, n=0, m-1\}$ denotes the set of matching terms.

For the initial value problem is $m = 1$.

Comparing the method of solution we followed and the usual singular perturbation solution we observe that both methods are formal and that the methods differ as far as it concerns the description of the types of formal limit functions that can arise. By application of theorem 4.1 we showed that in the case of the usual method the formal composite solution indeed approximates the exact solution (theorem 4.3).

In the following theorem it is demonstrated that the adjective "formal" could be omitted in an earlier stage: every formal limit function arising in step b. appears to be identical to a limit function of the exact solution.

Theorem 4.4 For the function $\phi(x; \varepsilon)$ satisfying the initial value problem (4.1), (4.2ab), the formal limit functions $\bar{\psi}_\nu(\xi_\nu)$, defined in b, c and d, are identical to the limit functions $\psi_\nu(\xi_\nu)$ defined by

$$\lim_{\xi_\nu} \left[\frac{\phi(\xi_\nu \delta_\nu; \varepsilon)}{\delta_\nu^*} - \psi_\nu(\xi_\nu) \right] = 0.$$

Proof From theorem 4.3 it follows that

$$(4.19) \quad \phi(x; \varepsilon) = \bar{\phi}_0(x; \varepsilon) + Z_0(x; \varepsilon),$$

where $Z_0(x; \varepsilon)$ is $O(\varepsilon)$ uniformly for $0 \leq x \leq 1$ and $\bar{\phi}_0$ is given in (4.18). Applying the definition of limit functions we obtain

$$\lim_{\xi_\nu} [\bar{\psi}_0(x) - \bar{\psi}_{\nu_1}(x) + \bar{\psi}_1(x/\varepsilon) + Z_0(x; \varepsilon) - \psi_\nu(\xi_\nu)] = 0, \quad x = \xi_\nu \delta_\nu.$$

It turns out that $\psi_\nu(\xi_\nu) \equiv \bar{\psi}_\nu(\xi_\nu)$ for all $\delta_\nu < 1$.

As a direct consequence of this theorem we may conclude that the matching conditions for the formal limit functions are well-posed (step c), because these relations also hold for the limit functions of the exact solution, as proved in theorem 3.3. A same argument applies to the construction of the formal composite function (4.17).

In applied mathematical problems we frequently meet the supposition that the solution of the limit equation equals the limit of the exact solution. In this section we have proved by means of rigorous analysis that this supposition is correct for the initial value problem (4.1), (4.2).

4.3 THE BOUNDARY VALUE PROBLEM FOR AN ORDINARY SECOND ORDER DIFFERENTIAL EQUATION

An analysis of the mathematical foundations of the singular perturbation method for the boundary value problem will show a great resemblance to the initial value problem of section 4.2. Again we study the function $\phi(x;\varepsilon)$, defined on the interval $0 \leq x \leq 1$, satisfying the differential equation

$$(4.20) \quad L_\varepsilon \phi \equiv \varepsilon L_2 \phi + L_1 \phi = h(x), \quad 0 < \varepsilon \ll 1,$$

under the same conditions as in (4.1). However, $b_1(x)$ may now be either positive or negative on the interval. For $b_1(x) > 0$ we expect a boundary layer near $x = 0$ and for $b_1(x) < 0$ one near $x = 1$ (see lemma 4.3). For the function $\phi(x;\varepsilon)$ we have the following boundary values

$$(4.21a) \quad \phi(0;\varepsilon) = p(\varepsilon) = p_0, \quad p_0 \neq 0,$$

$$(4.21b) \quad \phi(1;\varepsilon) = q(\varepsilon) = q_0.$$

First, the maximum principle is applied for the boundary value problem. Besides the possibility of proving the validity of the asymptotic solution, we are also able to determine the location of the boundary layer with this principle (lemma 4.3).

Lemma 4.2 Let the twice continuously differentiable functions $\phi(x;\epsilon)$ and $\psi(x;\epsilon)$ satisfy

$$|L_\epsilon \phi| \leq -L_\epsilon \psi$$

with L_ϵ being given in (4.1), and

$$|\phi(0;\epsilon)| \leq \psi(0;\epsilon), \quad |\phi(1;\epsilon)| \leq \psi(1;\epsilon).$$

Then

$$|\phi(x;\epsilon)| \leq \psi(x;\epsilon)$$

within $0 \leq x \leq 1$.

Proof The function $V(x;\epsilon) = -\psi(x;\epsilon) + \phi(x;\epsilon)$ satisfies the differential inequality $L_\epsilon V \geq 0$, so in accordance with the maximum principle $V(x;\epsilon)$ does not have a positive maximum on the interval $0 < x < 1$. For this reason and because $V(0;\epsilon) \leq 0$, $V(1;\epsilon) \leq 0$ we conclude that $V(x;\epsilon) \leq 0$ on the interval $0 \leq x \leq 1$. Similarly we show that the function $W(x;\epsilon) = -\psi(x;\epsilon) - \phi(x;\epsilon)$ is non-positive on $0 \leq x \leq 1$. On the interval $0 \leq x \leq 1$ both $-\psi(x;\epsilon) + \phi(x;\epsilon) \leq 0$ and $-\psi(x;\epsilon) - \phi(x;\epsilon) \leq 0$ hold, so that $|\phi(x;\epsilon)| \leq \psi(x;\epsilon)$.

Lemma 4.3 For the function $\phi(x;\epsilon)$ satisfying (4.20), (4.21ab) a number M independent of ϵ exist such that

$$|\phi(x;\epsilon) - p_0| \leq Mx, \quad \text{if } b_1(x) < 0,$$

and

$$|\phi(x;\epsilon) - q_0| \leq M(1-x), \quad \text{if } b_1(x) > 0.$$

Proof We only deal with the case where $b_1(x) > 0$. Let us consider $\psi(x) = M(1-x)$ as a barrier-function of $\phi^*(x;\epsilon) = \phi(x;\epsilon) - q_0$,

$$L_\epsilon \phi_\epsilon^* = h(x) + q_0(\epsilon a_0(x) - b_0(x))$$

$$-L_\epsilon \psi \geq M(b_1(x) - b_0(x)).$$

If we choose M , such that

$$M \cdot \min(b_1(x) - b_0(x)) \geq \max(h(x) + q_0(\epsilon a_0(x) - b_0(x))),$$

then

$$|L_\epsilon \phi_\epsilon^*| \leq -L_\epsilon \psi.$$

All conditions of lemma 4.2 are satisfied, so that

$$|\phi_\epsilon^*(x; \epsilon)| \leq M(1-x).$$

This lemma carries the consequence that the derivative to x of $\phi(x; \epsilon)$ has to be bounded with respect to ϵ near $x = 0$ for $b_1(x) < 0$ and near $x = 1$ for $b_1(x) > 0$. Therefore, the boundary layer is to be expected at the opposite boundary. In the sequel it is assumed that $b_1(x) > 0$.

Theorem 4.5 Let $Z(x; \epsilon)$, defined on the interval $0 \leq x \leq 1$, satisfy the differential equation

$$L_\epsilon Z = h(x; \epsilon)$$

with L_ϵ as in (4.1), and have given boundary values $Z(0; \epsilon)$, $Z(1; \epsilon)$. If $|Z(0; \epsilon)| \leq m\epsilon^{\mu_1}$, $|Z(1; \epsilon)| \leq m\epsilon^{\mu_2}$ and $|h(x; \epsilon)| \leq m\epsilon^{\mu_3}$ on the interval $0 \leq x \leq 1$, then a real number K independent of m and ϵ exists such that

$$|Z(x; \epsilon)| \leq Km\epsilon^\alpha, \quad \alpha = \min(\mu_1, \mu_2, \mu_3), \quad 0 \leq x \leq 1.$$

Proof Let s be a number that satisfies the inequalities

$\epsilon a_1(x) + b_1(x) \geq 1/s$, $\epsilon a_0(x) + b_0(x) \geq -2s$ and $s > 1$, then $\psi(x; \epsilon) = m\epsilon^\alpha e^{sx}$ is a barrier-function for $Z(x; \epsilon)$, $\psi(0; \epsilon) = m\epsilon^\alpha \geq m\epsilon^{\mu_1}$,

$\psi_1(1;\epsilon) = m\epsilon^\alpha e^s \geq m\epsilon^{\mu_2}$ and $-L_\epsilon \psi \geq -(s^2\epsilon + 1/s \cdot s - 2s)m\epsilon^\alpha e^{sx} \geq (-s^2\epsilon - 1 + 2s)m\epsilon^\alpha \geq m\epsilon^\alpha \geq |L_\epsilon \phi|$ for $0 < \epsilon \leq 2(s-1)/s^2$. Application of lemma 4.2 completes the proof of theorem 4.5.

The singular perturbation solution of the boundary value problem (4.20), (4.21) is as follows.

We suppose that for $\phi(x;\epsilon)$ an approximation exists of type

$$(4.22) \quad \phi(x;\epsilon) = U_0(x) + Z_U(x;\epsilon),$$

where $U_0(x)$ satisfies the differential equation

$$L_1 U_0 = h(x).$$

The function $U_0(x)$ can only satisfy one boundary condition, we expect that it is at $x = 1$, because of the boundedness of the derivative of ϕ (see lemma 4.3). Thus $U_0(x)$ takes the form

$$U_0(x) = q_0 - \int_x^1 \exp\left\{-\int_x^{\bar{x}} \frac{b_0(\hat{x})}{b_1(\hat{x})} d\hat{x}\right\} \frac{h(\bar{x}) - q_0 b_0(\bar{x})}{b_1(\bar{x})} d\bar{x}.$$

Further, we introduce the local transformation $x = \xi\epsilon$ and assume that in the domain $0 \leq x \leq K\epsilon$ with K an arbitrarily large positive number independent of ϵ , there exists an approximation of the type

$$(4.23) \quad \phi(x;\epsilon) = V_0(\xi) + \epsilon V_1(\xi) + Z_V(x;\epsilon), \quad x = \xi\epsilon,$$

where V_0 and V_1 satisfy the equations (see section 4.2)

$$(4.24) \quad M_0 V_0 = 0, \quad M_0 V_1 = -M_1 V_0 + h(0)$$

and have the boundary values

$$(4.25) \quad V_0(0) = p_0, \quad V_1(0) = 0.$$

Moreover, the following matching condition holds

$$(4.26) \quad U_0(0) = \lim_{\xi \rightarrow \infty} V_0(\xi).$$

It is easily established that

$$V_0(\xi) = \{p_0 - U_0(0)\}e^{-b_1(0)\xi} + U_0(0)$$

satisfies all conditions.

The proofs of the following two theorems are similar to the proofs of, respectively, theorems 4.3 and 4.4 and will, therefore, be omitted.

Theorems 4.6 Let the function $\phi(x;\varepsilon)$, defined on the interval $0 \leq x \leq 1$, satisfy the differential equation

$$L_\varepsilon \phi(x;\varepsilon) = h(x)$$

and have the boundary values

$$\phi(0;\varepsilon) = p_0, \quad p_0 \neq 0.$$

$$\phi(1;\varepsilon) = q_0.$$

Then it is possible to approximate the function $\phi(x;\varepsilon)$ by

$$\phi(x;\varepsilon) = U_0(x) + V_0(\xi) - U_0(0) + Z_0(x;\varepsilon), \quad x = \xi\varepsilon,$$

where $Z_0(x;\varepsilon) = o(\varepsilon)$ uniformly for $0 \leq x \leq 1$.

The construction of a formal asymptotic approximation consists of the same five steps as the method we used for the initial value problem. Only for d. another condition arises

d'. The formal limit function $\bar{\omega}(x)$ of (4.17) has to satisfy

$$\bar{\omega}(1) = q_0,$$

and a formal limit function $\bar{\psi}_b(\xi_b)$ exists with

$$\bar{\psi}_b(0) = p_0.$$

In table I column d changes into

$$C_0 = \left\{ q_0 - \int_0^1 \exp\left(-\int_{\bar{x}}^1 \frac{b_0(\bar{x})}{b_1(\bar{x})} d\bar{x}\right) \frac{h(\bar{x})}{b_1(\bar{x})} d\bar{x} \right\} / \left\{ 1 + \exp\left(-\int_0^1 \frac{b_0(\bar{x})}{b_1(\bar{x})} d\bar{x}\right) \right\},$$

$$C_{v_1} = C_0,$$

$$D_1 = p_0 - C_0, \quad E_1 = C_0,$$

$$F_{v_2} = p_0, \quad G_{v_2} = 0.$$

It appears that also for this class of problems the solution of the limit equation equals the limit of the exact solution as we will see in the following theorem.

Theorem 4.7 For the function $\phi(x;\varepsilon)$ satisfying the boundary value problem (4.20), (4.21ab), the formal limit function $\bar{\psi}_v(\xi_v)$, defined in b, c and d', are identical to the limit functions $\psi_v(\xi_v)$ defined by

$$(4.27) \quad \lim_{\xi_v} \left[\frac{\phi(\xi_v \delta_v; \varepsilon)}{\delta_v^*} - \psi_v(\xi_v) \right] = 0.$$

Remarks

1. When $p_0 = 0$, there arise non-equivalent limit functions. See example 3.3 and remark at table I.
2. When the coefficient $b_1(x)$ of L_ε vanishes at $x = 0$ it appears that the thickness of the boundary layer depends on the behaviour of $b_1(x)$ at $x = 0$. For example, if $b_1(x) = x$, the boundary layer will have a thickness of $O(\sqrt{\varepsilon})$.
3. An example of a differential equation corresponding to a multiple boundary layer ($m > 1$ in (4.18)) is given in [6].

4.4 THE ELLIPTIC PROBLEM

In this section we summarize the results of Eckhaus and De Jager [7] on this subject. The method of solution is closely related to the one that solves the boundary value problem for ordinary differential equations. Our contribution consists of a theorem which shows that in this case the formal limit functions are also equivalent to the limit functions of the exact solution.

We study the differential equation

$$(4.28) \quad L_\epsilon \phi \equiv \epsilon L_2 \phi + L_1 \phi = h(x,y), \quad 0 < \epsilon \ll 1,$$

valid in a strictly convex bounded domain G . L_1 and L_2 denote the differential operators

$$L_2 \equiv a(x,y) \frac{\partial^2}{\partial x^2} + 2b(x,y) \frac{\partial^2}{\partial x \partial y} + c(x,y) \frac{\partial^2}{\partial y^2} + d(x,y) \frac{\partial}{\partial x} + e(x,y) \frac{\partial}{\partial y} + f(x,y),$$

$$L_1 \equiv - \frac{\partial}{\partial x} - g(x,y).$$

At the boundary Γ of G the function ϕ has the values

$$(4.29) \quad \phi(x,y;\epsilon) \Big|_{\Gamma} = p_0(x,y;\epsilon).$$

We assume that the coefficients $a(x,y)$, $b(x,y)$, ..., $h(x,y)$ are continuously differentiable up to the third order. Moreover, we suppose that $a(x,y) > 0$ and $g(x,y) - \epsilon f(x,y) \geq 0$ in \bar{G} and that the differential operator L_2 is elliptic in \bar{G} .

The characteristics of the operator L_1 are the lines $y = \text{constant}$. In a neighbourhood of a point where such a characteristic is tangent to the boundary an approximation of the usual singular perturbation type is not valid. Therefore, the following theorem will appear to be very appropriate in the applications. The proof is given in [7].

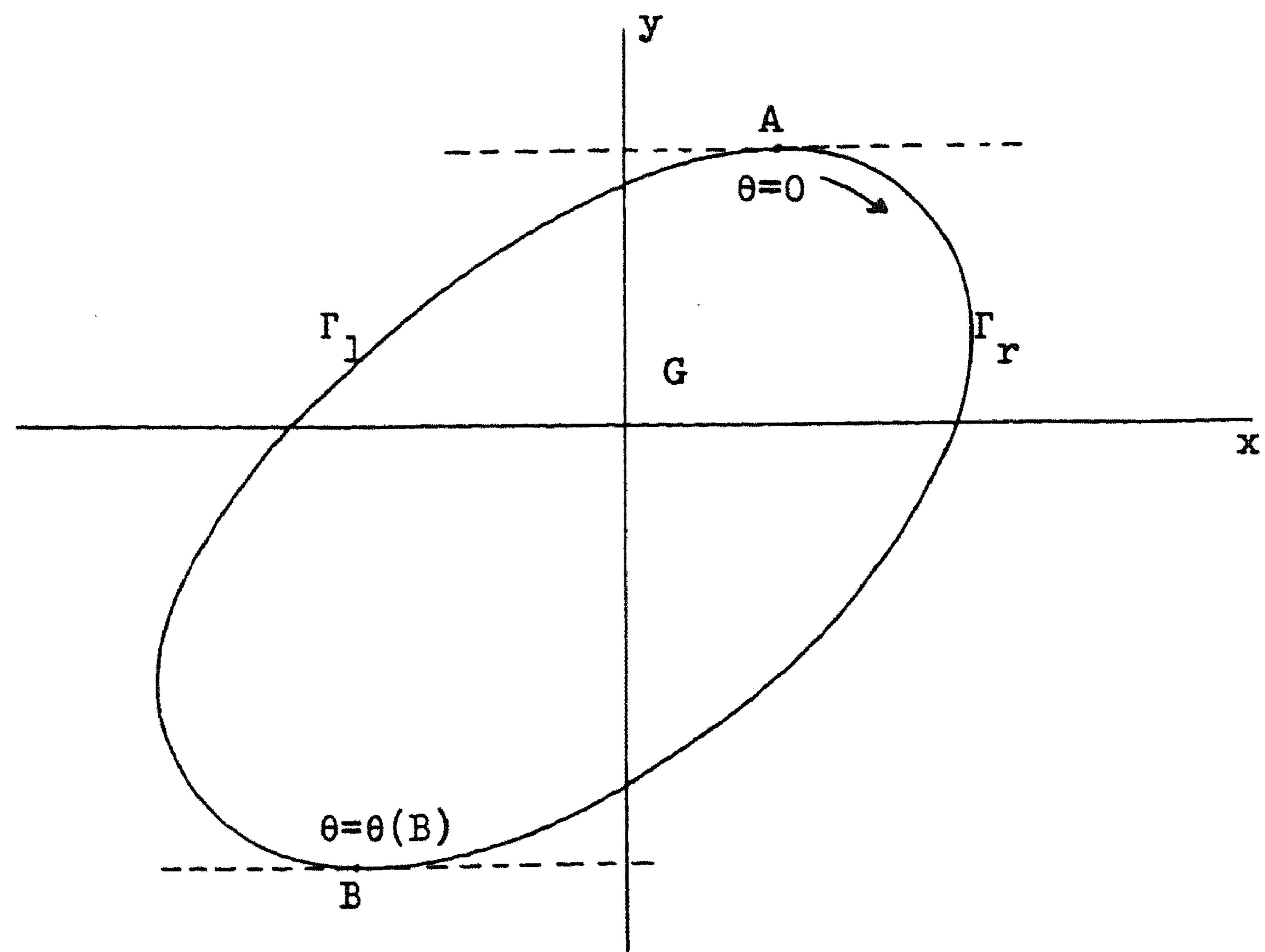

fig. 4.1

Theorem 4.8 Let the function $Z(x,y;\epsilon)$, defined in the domain G , satisfy the differential equation

$$L_{\epsilon} Z = h(x,y;\epsilon),$$

have prescribed values at the boundary Γ , at which there are two unique points $A(x_1, y_1)$ and $B(x_2, y_2)$ where the ordinates take on maximal and minimal values, respectively. Further, it is assumed that $Z(x,y;\epsilon)$ is uniformly bounded in G for sufficiently small values of ϵ .

If $|Z(x,y;\epsilon)| \leq m\epsilon^{\mu_1}$ at Γ and $|h(x,y;\epsilon)| \leq m\epsilon^{\mu_2}$ in \bar{G} with exception of arbitrarily small neighbourhoods $V(A)$ and $V(B)$ of A and B , where $h(x,y;\epsilon)$ is singular, and if $\min(\mu_1, \mu_2) \leq 1$, then there exists a real number K independent of m and ϵ , such that

$$|Z(x,y;\varepsilon)| \leq K\varepsilon^\alpha, \quad \alpha = \min(\mu_1, \mu_2),$$

in $\overline{G - V(A) - V(B)}$.

An approximation of $\phi(x,y;\varepsilon)$ is constructed with the singular perturbation method in the following manner.

Let Γ_l be the part of the boundary at the left-hand side of A and B, and Γ_r the part at the right-hand side. Γ_l is represented by the function $x = \gamma_l(y)$ and Γ_r by $x = \gamma_r(y)$. We suppose that outside a neighbourhood of Γ_r an approximation exists of the type

$$\phi(x,y;\varepsilon) = U_0(x,y) + Z_U(x,y;\varepsilon),$$

where

$$(4.30) \quad U_0(x,y) = p_0(\gamma_l(y), y) - \int_{\gamma_l(y)}^x \exp\left\{-\int_p^x g(\bar{p}, y) d\bar{p}\right\} \\ \{h(p, y) + g(p, y)p_0(\gamma_l(y), y)\} dp.$$

Further, we introduce the coordinate system (ρ, θ) , ρ varies along the inner normal of a point of Γ_r ($\rho=0$ on Γ_r) and θ varies along Γ_r ($\theta(A)=0$).

Substitution of these variables in the operator L_ε yields the differential operator

$$S_\varepsilon \equiv \varepsilon\left\{\alpha(\rho, \theta)\frac{\partial^2}{\partial \rho^2} + 2\beta(\rho, \theta)\frac{\partial^2}{\partial \rho \partial \theta} + \gamma(\rho, \theta)\frac{\partial^2}{\partial \theta^2} + \zeta(\rho, \theta)\frac{\partial}{\partial \rho} + \eta(\rho, \theta)\frac{\partial}{\partial \theta} + f(\rho, \theta)\right\} + \\ -\left\{\mu(\rho, \theta)\frac{\partial}{\partial \rho} + \nu(\rho, \theta)\frac{\partial}{\partial \theta} + g(\rho, \theta)\right\}.$$

The thickness of the boundary layer near Γ_r is determined in the same way as in the preceding sections. It appears that a boundary layer contribution arises in the local coordinates ξ, θ , where

$$(4.31) \quad \xi = \rho/\varepsilon.$$

Substitution of (4.31) in S_ε leads to the operator expansion

$$\varepsilon S_\varepsilon \equiv M_0 + \varepsilon M_1 + \varepsilon^2 \bar{M}_2,$$

$$M_0 \equiv \alpha_0(0, \theta) \frac{\partial^2}{\partial \xi^2} - \mu_0(0, \theta) \frac{\partial}{\partial \xi},$$

$$M_1 \equiv \alpha_1(0, \theta) \xi \frac{\partial^2}{\partial \xi^2} + 2\beta_0(0, \theta) \frac{\partial^2}{\partial \xi \partial \theta} + \gamma_0(0, \theta) \frac{\partial^2}{\partial \theta^2} + \{\zeta_1(0, \theta) \xi - \mu_2(0, \theta) \xi^2\} \frac{\partial}{\partial \xi} +$$

$$-\{\eta_0(0, \theta) - \nu_1(0, \theta) \xi\} \frac{\partial}{\partial \theta} + \{f_0(\theta) - g_1(\theta) \xi\}.$$

The operator \bar{M}_2 contains the truncated terms of the operator expansion. We suppose that the following approximation is valid for $0 \leq \rho \leq \rho_0$, $0 < \theta < \theta(B)$ with ρ_0 sufficiently small (but independent of ε)

$$\phi(x, y; \varepsilon) = V_0(\rho/\varepsilon, \theta) + Z_V(x, y; \varepsilon),$$

where $V_0(\rho/\varepsilon, \theta)$ satisfies

1. the differential equation $M_0 V_0 = 0$,
2. the boundary condition $V_0(0, \theta) = p_0(x, y) \Big|_{\Gamma_r}$
3. the matching condition $\lim_{\xi \rightarrow \infty} V_0(\xi, \theta) = U_0(x, y) \Big|_{\Gamma_r}$.

A solution that fulfils these three conditions has the form

$$V_0(\xi, \theta) = \{p_0(x, y) - U_0(x, y)\} \Big|_{\Gamma_r} \exp \left[\xi \frac{\mu_0(\theta)}{\alpha_0(\theta)} \right] + U_0(x, y) \Big|_{\Gamma_r},$$

$$\mu_0(\theta) < 0.$$

We multiply this boundary layer term with a smoothing factor $K(\rho/\rho_0)$ which is zero outside the interval $0 < \theta < \theta_B$ and has the following values inside

the interval

1. $K(\rho/\rho_0) = 1$ for $0 \leq \rho \leq 1/3\rho_0$,
2. $K(\rho/\rho_0)$ is sufficiently many times differentiable and monotonic decreasing for $1/3\rho_0 \leq \rho \leq 2/3\rho_0$,
3. $K(\rho/\rho_0) = 0$ for $\rho \geq \rho_0$.

In this manner one has obtained a function

$$\bar{V}_0(\xi, \theta) = K(\rho/\rho_0)V_0(\xi, \theta), \quad \rho = \xi\varepsilon,$$

which holds in the complete domain \bar{G} .

In the following theorem it is demonstrated that an approximation of the solution can be made which is composed of the terms U_0 and \bar{V}_0 .

Theorem 4.9 Let the function $\phi(x, y; \varepsilon)$, defined in the strictly convex domain G , satisfy the differential equation

$$L_\varepsilon \phi = h(x, y)$$

and have the boundary values

$$\phi(x, y; \varepsilon) = p(x, y; \varepsilon) = p_0(x, y)$$

at Γ . Then it is possible to approximate the function $\phi(x, y; \varepsilon)$ by

$$\phi(x, y; \varepsilon) = U_0(x, y) + \bar{V}_0(\rho/\varepsilon, \theta) - U_0(x, y) \Big|_{\Gamma_r} + Z_0(x, y; \varepsilon),$$

so that $Z_0(x, y; \varepsilon) = o(\varepsilon)$ in $\overline{G - V(A) - V(B)}$.

Proof See [7].

Further, a study will be made of the various types of formal limit functions arising in the elliptic problem.

In five steps we come to the construction of a formal asymptotic approximation, which is uniformly valid in $\overline{G - V(A) - V(B)}$:

- a. All degenerations of S_ε are taken into consideration. We substitute $\rho = \xi_\nu \delta_\nu(\varepsilon)$ in $S_\varepsilon \phi = h(\rho, \theta)$. Further, both sides of this equation are multiplied by an order function $\overline{\delta}_\nu^*(\varepsilon)$ such that $\lim_{\varepsilon \rightarrow 0} \overline{\delta}_\nu^* S_\varepsilon = S_0^{(\nu)}$, where the coefficients of the limit operator are of order $O(1)$.
- b. We introduce the formal limit function $\overline{\psi}_\nu(\xi_\nu, \theta)$.

Definition 4.2 We say that for transformation $x = \xi_\nu \delta_\nu(\varepsilon)$ a formal limit function $\overline{\psi}_\nu(\xi_\nu, \theta)$ exists, if there exists a non-trivial solution of

$$S_0^{(\nu)} \overline{\psi}_\nu(\xi_\nu, \theta) = \overline{h}_\nu(\xi_\nu, \theta), \quad \overline{h}_\nu(\xi_\nu, \theta) = \lim_{\varepsilon \rightarrow 0} \overline{\delta}_\nu^* h(\xi_\nu \delta_\nu, \theta)$$

on some interval of ξ_ν for $0 < \lambda \leq \theta \leq \theta(B) - \lambda$, where λ is an arbitrarily small positive number.

- c. The matching condition can be described as follows:

There exists an order function $\overline{\delta}_\nu \ll_{as} 1$ such that

$$\lim_{\xi_\mu} \left[\frac{\overline{\delta}_\nu^*}{\overline{\delta}_\mu^*} \overline{\psi}_\nu \left(\frac{\delta_\mu}{\delta_\nu} \xi_\mu, \theta \right) \right] = \lim_{\xi_\mu} \left[\frac{\overline{\delta}_{\nu+\Delta}^*}{\overline{\delta}_\mu^*} \overline{\psi}_{\nu+\Delta} \left(\frac{\delta_\mu}{\delta_{\nu+\Delta}} \xi_\mu, \theta \right) \right],$$

$$\rho = \xi_\mu \delta_\mu, \quad \delta_{\nu+\Delta} \ll_{as} \delta_\mu \ll_{as} \delta_\nu,$$

$$\text{if } \overline{\delta}_\nu \ll_{as} \delta_{\nu+\Delta} / \delta_\mu \ll_{as} 1.$$

- d. The formal limit function $\overline{\omega}(\rho, \theta)$ satisfying $L_1 \overline{\omega} = h(\rho, \theta)$ is required to have the values $\overline{\omega}(x, y) = p_0(x, y)$ for $y = \gamma_1(x)$. A formal limit function $\overline{\psi}_\nu(\xi_\nu, \theta)$ exists with the values

$$\bar{\psi}_b(\rho, \theta) = p_0(x, y)$$

for $y = \gamma_r(x)$.

e. The formal uniformly valid asymptotic approximation has the form

$$\bar{\phi}_0(\rho, \theta; \varepsilon) = \sum_{n=0}^m \bar{\psi}_n(\rho/\delta_n, \theta) \delta_n^* - \sum_{n=0}^{m-1} \bar{\psi}_{v_{n+1}}(\rho/\delta_n, \theta) \delta_{v_{n+1}}^*.$$

This composition of terms is suggested by the results we derived for explicitly given functions depending on one variable (see also 4.2e). For the elliptic problem we have $m = 1$. We remark that this formal approximation holds uniformly with the exception of neighbourhoods of A and B.

Theorem 4.10 For the function $\phi(x, y; \varepsilon)$ satisfying the boundary value problem (4.28), (4.29) the formal limit functions determined by b, c and d, are identical to the limit functions $\psi_v(\xi_v, \theta)$ defined by

$$\lim_{\xi_v} \left[\frac{\phi(\rho, \theta; \varepsilon)}{\delta_v^*} - \psi_v(\xi_v, \theta) \right] = 0, \quad \rho = \xi_v \delta_v.$$

Proof Similar to the proof of theorem 4.7.

In this chapter we have shown that for three classes of problems the different steps in the construction of a formal approximation are correct. We have obtained this result by imposing those conditions upon the formal limit functions which were proved to be valid for the limit functions of the exact solution (see chapter 3). Theorems 4.4, 4.7 and 4.10 prove that these two types of limit functions are identical. From this identity it follows that the matching conditions of step c and the method of composing a solution as in step e are indeed correct.

Remark If in the elliptic problem a part of the boundary Γ coincides with a characteristic of L_1 (a line $y = \text{constant}$), then along this part of the boundary a so-called parabolic boundary layer of thickness $O(\sqrt{\varepsilon})$ arises. This problem is dealt with in sections 5.6 and 5.7.

CHAPTER V NON-UNIFORM CONVERGENCE OF FUNCTIONS OF TWO VARIABLES

5.1 INTRODUCTORY REMARKS

In the preceding chapter examples were given of singular perturbation problems having as essential feature "the stretching of one coordinate". Theorems 4.4, 4.7 and 4.10 of this chapter form a linkage between at one side the foundations of matched asymptotic expansions (chapter 3) and at the other side the examples just mentioned.

However, the theory of chapter 3 is not complete, because not all aspects of linear singular perturbations are covered by this theory. In section 4.4 an approximation of the solution of a linear elliptic singular perturbation problem was given, which is valid in the domain of definition of the function with the exception of the neighbourhoods of two points A and B. In these points the characteristics of L_1 (the lines $y=\text{constant}$) are tangent to the boundary of the domain. In chapter 6, a method will be developed which produces an approximation that also is valid near these singular points.

As an introduction we investigate in the first part of this chapter the behaviour of explicitly given functions converging non-uniformly near an isolated point of the x,y -plane. The material of this chapter preceding theorem 5.3 resembles the theory of chapter 2 very much. In the remaining part some problems arise which are specific for the two-dimensional case. We solve them by introducing the supplementary matching theorem 5.4, which enables us to treat two-dimensional singular perturbation problems.

In section 5.5 a uniformly valid asymptotic approximation of a function $\phi(x,y;\epsilon)$ is composed of the limit functions. The function ϕ may converge non-uniformly near a curve as well as near an isolated point of the domain G of the x,y -plane. Here our efforts are concentrated at a uniform description of the various configurations of limit functions, which depend on the type of functions $\phi(x,y;\epsilon)$.

5.2 EXTENSION THEOREMS

Let $\phi(x,y;\varepsilon)$, defined in $G_\varepsilon = \{x,y,\varepsilon: 0 \leq x \leq R, 0 \leq y \leq R, 0 < \varepsilon \leq \varepsilon^*\}$, and $\omega(x,y)$, defined in $G = \{x,y: 0 \leq x \leq R, 0 \leq y \leq R, (x,y) \neq (0,0)\}$, be continuous functions, and let the limit

$$(5.1) \quad \lim_{\varepsilon \rightarrow 0} [\phi(x,y;\varepsilon) - \omega(x,y)] = 0$$

converge non-uniformly in G and uniformly in $\bar{G} - G_A$, where $G_A = \{x,y: 0 \leq x \leq A_x, 0 \leq y \leq A_y\}$ for any $0 < A_x, A_y < R$. Then it can be demonstrated that there exist functions $\varepsilon_0(q,s)$ with $s = (x,y)$ having the following properties:

- a. $|\phi(s;\varepsilon) - \omega(s)| \leq q$ for $0 < \varepsilon \leq \varepsilon_0(q,s)$ and $s \in G$.
- b. $\varepsilon_0(q,s)$ is continuous in q, x and y .
- c. $\varepsilon_0(q,s)$ is monotonic increasing in q, x and y .
- d. $\lim_{q \rightarrow 0} \varepsilon_0(q,s) = 0$, $\lim_{s \rightarrow (0,0)} \varepsilon_0(q,s) = 0$.
- e. Let $x = x(\lambda), y = y(\lambda)$ be an arbitrary path along which the origin is approached, $(x(0), y(0)) = (0,0)$, and let x, y be monotonic, non-decreasing for $0 \leq \lambda \leq \lambda^*$. Then for an arbitrarily small $\lambda_0 > 0$ values λ_k exist with $0 < \lambda_k < \lambda_0$ such that $|\phi(s(\lambda_k), \varepsilon) - \omega(s(\lambda_k))| > q$ for $\varepsilon = \varepsilon_0(q, s(\lambda_k)) + \sigma$, where σ is positive and arbitrarily small.

The functions $\varepsilon_0(q,s)$ give a complete description of the non-uniform behaviour of $\phi(s;\varepsilon)$.

Further, we can show that there exist positive, continuous functions $\bar{\varepsilon}_0(s)$, monotonic increasing in x and y , having the property

$$\lim_{s \rightarrow (0,0)} \frac{\bar{\varepsilon}_0(s)}{\varepsilon_0(q,s)} = 0 \quad \text{for } 0 < q \leq q_0.$$

The proofs of the following theorems are omitted, because they are similar to the proof of theorem 3.4.

Theorem 5.1 Let $\phi(s;\varepsilon)$ be a continuous function, defined in the domain G_ε , and let the limit

$$\lim_{\varepsilon \rightarrow 0} [\phi(s;\varepsilon) - \omega(s)] = 0$$

hold uniformly in the domain $\bar{G} - G_A$ for $0 < \varepsilon \leq \varepsilon_0(A_x, A_y)$, where $G_A = \{x, y: 0 \leq x < A_x, 0 \leq y < A_y\}$ and (A_x, A_y) is chosen arbitrarily. Then there exist functions $\varepsilon = \bar{\varepsilon}_0(s)$, positive, continuous and monotonic increasing in x and y , with $\lim_{s \rightarrow (0,0)} \bar{\varepsilon}_0(s) = 0$, such that the limit

$$\lim_{\varepsilon \rightarrow 0} [\phi(s;\varepsilon) - \omega(s)] = 0$$

is uniformly valid in \bar{G} for $0 \leq \varepsilon \leq \bar{\varepsilon}_0(s)$.

Theorem 5.2 Let $\phi(s;\varepsilon)$ be a continuous function, defined in the domain G_ε , and let the limit

$$\lim_{\varepsilon \rightarrow 0} [\phi(s;\varepsilon) - \omega(s)] = 0$$

hold uniformly in the domain $\bar{G} - G_A - G_B$, where $G_A = \{x, y: 0 \leq x < A_x, 0 \leq y < A_y\}$ and $G_B = \{x, y: B_x < x \leq R, B_y < y \leq R\}$ (A and B arbitrarily chosen). Then there exist functions $\varepsilon = \bar{\varepsilon}_0(s)$, as defined in theorem 5.1, and, moreover, functions $\varepsilon = \bar{\bar{\varepsilon}}_0(s)$, continuous and monotonic decreasing in x and y with $\lim_{s \rightarrow (R,R)} \bar{\bar{\varepsilon}}_0(s) = 0$, such that the limit

$$\lim_{\varepsilon \rightarrow 0} [\phi(s;\varepsilon) - \omega(s)] = 0$$

is uniformly valid in \bar{G} for $0 \leq \varepsilon \leq \min[\bar{\varepsilon}_0, \bar{\bar{\varepsilon}}_0, \varepsilon^*]$.
(R may tend to infinity.)

5.3 LIMIT FUNCTIONS

In order to study the non-uniform behaviour of the functions $\phi(s,y;\varepsilon)$ defined in the forgoing section all paths, along which the origin can be approached in \bar{G}_ε , are considered. For that purpose the order functions

$\delta_{x,v}(\varepsilon)$, $\delta_{y,v}(\varepsilon)$ are introduced so that an arbitrary path always has the form

$$(5.2) \quad x = \xi_v \delta_{x,v}(\varepsilon), \quad y = \eta_v \delta_{y,v}(\varepsilon).$$

Let $\psi_v(\xi_v, \eta_v)$ be a function satisfying the limit

$$(5.3) \quad \lim_{\xi_v, \eta_v} \left[\frac{\phi(x, y; \varepsilon)}{\delta_v^*(\varepsilon)} - \psi_v(\xi_v, \eta_v) \right] = 0, \quad (\xi_v, \eta_v \text{ fixed and } \varepsilon \rightarrow 0),$$

where (5.2) is substituted in $\phi(x, y; \varepsilon)$.

Definition 5.1 The limit of the singular function $\phi(x, y; \varepsilon)$ exists for a transformation (5.2), if a non-trivial function $\psi_v(\xi_v, \eta_v)$ and an order function $\delta_v^*(s)$ exist, such that (5.3) holds for some values of ξ_v and η_v . ψ_v is called a limit function.

Let $\varepsilon = \delta_{x,v}^{-1}(p)$ and $\varepsilon = \delta_{y,v}^{-1}(q)$ be the inverse function of $p = \delta_{x,v}(\varepsilon)$ and $q = \delta_{y,v}(\varepsilon)$, then (5.2) leads to the relation

$$(5.4) \quad \delta_{x,v}^{-1}(x/\xi_v) = \delta_{y,v}^{-1}(y/\eta_v).$$

Using this relation we construct the pair of order functions $\{\delta_{x,0}^{(q)}, \delta_{y,0}^{(q)}\}$ such that

$$x = \xi_v \delta_{x,0}^{(q)}(\varepsilon), \quad y = \eta_v \delta_{y,0}^{(q)}(\varepsilon)$$

satisfy $\varepsilon = \varepsilon_0(q, s)$ of the foregoing sections.

From extension theorem 5.1 it follows that the limit

$$\lim_{\varepsilon \rightarrow 0} [\phi(x, y; \varepsilon) - \omega(x, y)] = 0$$

holds uniformly along a path (5.2), if $\delta_{x,0}^{(q)} \ll \delta_{x,v} < 1$,
 $\delta_{y,0}^{(q)} \ll \delta_{y,v} < 1$.

Example 5.1 We consider the function

$$\phi(x,y;\varepsilon) = \frac{1+3x}{x^2+y+2\varepsilon},$$

and observe that the limit

$$\lim_{\varepsilon \rightarrow 0} \left[\phi(x,y;\varepsilon) - \frac{1+3x}{x^2+y} \right] = 0$$

converges non-uniformly near $(x,y) = (0,0)$. Introduction of the so-called local coordinates ξ and η by the transformation

$$x = \xi\varepsilon^\alpha, \quad y = \eta\varepsilon^\beta, \quad \alpha, \beta > 0$$

leads to different limit functions $\psi(\xi,\eta)$ satisfying the limit

$$\lim_{\varepsilon \rightarrow 0} \left[\frac{\phi(x,y;\varepsilon)}{\delta^*(\varepsilon)} - \psi(\xi,\eta) \right] = 0.$$

Table II

$\psi(\xi,\eta)$	$\delta^*(\varepsilon)$	α, β
$1/\xi^2$	$\varepsilon^{-2\alpha}$	$0 < 2\alpha < \beta \leq 1$
$1/\eta$	$\varepsilon^{-\beta}$	$0 < \beta < 2\alpha \leq 1$
$1/(\xi^2+\eta)$	$\varepsilon^{-2\alpha}$	$0 < 2\alpha = \beta < 1$
$1/(\xi^2+\eta+2)$	ε^{-1}	$2\alpha = \beta = 1$
$1/(\xi^2+2)$	ε^{-1}	$2\alpha = 1 < \beta$
$1/(\eta+2)$	ε^{-1}	$\beta = 1 < 2\alpha$
$1/2$	ε^{-1}	$1 < \alpha, \beta$

5.4 THE MATCHING PRINCIPLE

In this section the matching principle for limit functions of two local variables will be formulated. It will appear that in the two-dimensional case the attention must be focused at matching of special ("significant") limit functions in order to give the matching principle a practical purpose.

When limit (5.3) holds uniformly in $\bar{G}^{(\nu)} - G_A^{(\nu)} - G_B^{(\nu)}$, where $\bar{G}^{(\nu)} = \{\xi_\nu, \eta_\nu: 0 \leq \xi_\nu, 0 \leq \eta_\nu\}$, $G_A^{(\nu)} = \{\xi_\nu, \eta_\nu: 0 \leq \xi_\nu < A_{x,\nu}, 0 \leq \eta_\nu < A_{y,\nu}\}$ and $G_B^{(\nu)} = \{\xi_\nu, \eta_\nu: B_{x,\nu} < \xi_\nu < \infty, B_{y,\nu} < \eta_\nu < \infty\}$ (A and B arbitrarily chosen), it follows from lemma 2.2 that

$$\left| \frac{\phi(x,y;\varepsilon)}{\delta_\nu^*(\varepsilon)} - \psi_\nu\left(\frac{x}{\delta_{x,\nu}}, \frac{y}{\delta_{y,\nu}}\right) \right| \underset{\text{as}}{=} \delta_\nu^{(r)}(\varepsilon) \ll_{\text{as}} 1,$$

so

$$(5.5a) \quad \phi(x,y;\varepsilon) = \psi_\nu\left(\frac{x}{\delta_{x,\nu}}, \frac{y}{\delta_{y,\nu}}\right) \delta_\nu^*(\varepsilon) + o(\delta_\nu^{(r)} \delta_\nu^*)$$

in that domain. Application of theorem 5.2 ($R \rightarrow \infty$) to limit (5.3) extends the domain of validity of (5.5a). Let $x = \xi_\mu \delta_{x,\mu}$, $y = \eta_\mu \delta_{y,\mu}$ be a path in this extended domain of convergence, then an order function $\delta_{\nu,\mu}^{(r)} \ll_{\text{as}} 1$ exist such that

$$(5.5b) \quad \phi(x,y;\varepsilon) = \psi_\nu\left(\frac{x}{\delta_{x,\nu}}, \frac{y}{\delta_{y,\nu}}\right) \delta_\nu^*(\varepsilon) + o(\delta_{\nu,\mu}^{(r)} \delta_\nu^*)$$

in $\bar{G}^{(\mu)} - G_A^{(\mu)} - G_B^{(\mu)}$, where $\bar{G}^{(\mu)} = \{\xi_\mu, \eta_\mu: 0 \leq \xi_\mu, 0 \leq \eta_\mu\}$, $G_A^{(\mu)} = \{\xi_\mu, \eta_\mu: 0 \leq \xi_\mu < A_{x,\mu}, 0 \leq \eta_\mu < A_{y,\mu}\}$ and $G_B^{(\mu)} = \{\xi_\mu, \eta_\mu: B_{x,\mu} < \xi_\mu < \infty, B_{y,\mu} < \eta_\mu < \infty\}$ (A and B arbitrarily chosen).

Before formulating the two-dimensional matching principle we mention some important consequences of the preceding theory. Let for an arbitrary path

$$x = \xi_\nu \delta_{x,\nu}, \quad y = \eta_\nu \delta_{y,\nu}$$

the limit

$$(5.6) \quad \lim_{\xi_v, \eta_v} \left[\frac{\phi(x, y; \varepsilon)}{\delta_v^*(\varepsilon)} - \psi_v(\xi_v, \eta_v) \right] = 0$$

hold uniformly in the domain $\bar{G}^{(v)} - G_A^{(v)}$, where $\bar{G} = \{\xi_v, \eta_v: 0 \leq \xi_v, 0 \leq \eta_v\}$ and $G_A^{(v)} = \{\xi_v, \eta_v: 0 \leq \xi_v < A_{x,v}, 0 \leq \eta_v < A_{y,v}\}$. Moreover, let the path

$$(5.7) \quad x = \xi_{v+\Delta} \delta_{x,v+\Delta}, \quad y = \eta_{v+\Delta} \delta_{y,v+\Delta},$$

be situated in the extended domain of uniform convergence of (5.6), and have the corresponding limit

$$(5.8) \quad \lim_{\xi_{v+\Delta}, \eta_{v+\Delta}} \left[\frac{\phi}{\delta_{v+\Delta}^*} - \psi_{v+\Delta}(\xi_{v+\Delta}, \eta_{v+\Delta}) \right] = 0.$$

Then according to the extension theorem the following limit is valid

$$(5.9) \quad \lim_{\xi_{v+\Delta}, \eta_{v+\Delta}} \left[\frac{\delta_{v+\Delta}^*}{\delta_v^*} \frac{\phi}{\delta_{v+\Delta}^*} - \psi_v \left(\xi_{v+\Delta} \frac{\delta_{y,v+\Delta}}{\delta_{x,v}}, \eta_{v+\Delta} \frac{\delta_{y,v+\Delta}}{\delta_{y,v}} \right) \right] = 0.$$

Notice that $\lim_{\varepsilon \rightarrow 0} \phi / \delta_{v+\Delta}^*$ exists and is non-zero, see (5.8).

Examination of the relation (5.9) reveals the following two interesting points:

1. the asymptotic behaviour of the limit function $\psi_v(\xi_v, \eta_v)$ is governed by the ratio $\delta_v^* / \delta_{v+\Delta}^*$ for $\varepsilon \rightarrow 0$. Only for $\delta_v^* \underset{\text{as}}{=} \delta_{v+\Delta}^*$ ψ_v tends to a bounded non-zero value.
2. substitution of (5.8) in (5.9) yields the relation

$$\lim_{\xi_{v+\Delta}, \eta_{v+\Delta}} \left[\frac{\delta_v^*}{\delta_{v+\Delta}^*} \psi_{v+\Delta} \left(\xi_{v+\Delta} \frac{\delta_{x,v+\Delta}}{\delta_{x,v}}, \eta_{v+\Delta} \frac{\delta_{y,v+\Delta}}{\delta_{y,v}} \right) \right] = \psi_{v+\Delta}(\xi_{v+\Delta}, \eta_{v+\Delta}),$$

which implies that for any order function $\hat{\delta}_v^* \ll 1$ an order function $\hat{\delta}_v^* \ll 1$ exists such that $\hat{\delta}_v^* \ll \delta_v^* / \delta_{v+\Delta}^* < 1$ or $\hat{\delta}_v^* \ll \delta_{v+\Delta}^* / \delta_v^* < 1$, if $\hat{\delta}_v^* \ll \delta_{x,v+\Delta} / \delta_{x,v} < 1$ and $\hat{\delta}_v^* \ll \delta_{y,v+\Delta} / \delta_{y,v} < 1$. This result expresses the continuous dependence of the set of order functions δ_v^* upon the sets of order functions $\{\delta_{x,v}, \delta_{y,v}\}$.

Assumption 5.1 All sets of bounding order functions $\{\delta_{x,v}^{(q)}, \delta_{y,v}^{(q)}\}$ consist of asymptotically equal order functions,

$$\delta_{x,v}^{(q_1)} \underset{\text{as}}{=} \delta_{x,v}^{(q_2)}, \quad \delta_{y,v}^{(q_1)} \underset{\text{as}}{=} \delta_{y,v}^{(q_2)}, \quad 0 < q_2 < q_1 < q^*.$$

Theorem 5.3 Let

$$(5.10) \quad \lim_{\xi_{v_1}, \eta_{v_1}} \left[\frac{\phi(x, y; \varepsilon)}{\delta_{v_1}^*(\varepsilon)} - \psi_{v_1}(\xi_{v_1}, \eta_{v_1}) \right] = 0,$$

and

$$(5.11) \quad \lim_{\xi_{v_2}, \eta_{v_2}} \left[\frac{\phi(x, y; \varepsilon)}{\delta_{v_2}^*(\varepsilon)} - \psi_{v_2}(\xi_{v_2}, \eta_{v_2}) \right] = 0,$$

where in (5.10) $x = \xi_{v_1} \delta_{x,v_1}$, $y = \eta_{v_1} \delta_{y,v_1}$, and in (5.11) $x = \xi_{v_2} \delta_{x,v_2}$,

$y = \eta_{v_2} \delta_{y,v_2}$ ($\delta_{x,v_2} = \delta_{x,v_1} \bar{\delta}_{x,v}$, $\delta_{y,v_2} = \delta_{y,v_1} \bar{\delta}_{y,v}$).

For approximately chosen order functions $\hat{\delta}_{x,v} \ll 1$, $\hat{\delta}_{y,v} \ll 1$

$(\bar{\delta}_{x,v}^{-1}(\hat{\delta}_{x,v}(\varepsilon)) \equiv \bar{\delta}_{y,v}^{-1}(\hat{\delta}_{y,v}(\varepsilon)))$, a set of paths

$$x = \xi_{\mu} \delta_{x,\mu}(\varepsilon), \quad y = \eta_{\mu} \delta_{y,\mu}(\varepsilon)$$

exists for which the relation

$$(5.12) \quad \lim_{\xi_{\mu}, \eta_{\mu}} \left[\frac{\delta_{v_1}^*}{\delta_{\mu}^*} \psi_{v_1} \left(\frac{\delta_{x,\mu}}{\delta_{x,v_1}} \xi_{\mu}, \frac{\delta_{y,\mu}}{\delta_{y,v_1}} \eta_{\mu} \right) \right] =$$

$$\lim_{\xi_{\mu}, \eta_{\mu}} \left[\frac{\delta_{v_2}^*}{\delta_{\mu}^*} \psi_{v_2} \left(\frac{\delta_{x,\mu}}{\delta_{x,v_2}} \xi_{\mu}, \frac{\delta_{y,\mu}}{\delta_{y,v_2}} \eta_{\mu} \right) \right]$$

holds, if $\hat{\delta}_{x,v} \ll \bar{\delta}_{x,v} < 1$, $\hat{\delta}_{y,v} \ll \bar{\delta}_{y,v} < 1$.

Proof Application of theorem 5.1 yields the uniformly converging limit

$$(5.13) \quad \lim_{\bar{\xi}_{v_1}, \bar{\eta}_{v_1}} \left[\frac{\phi}{\delta_{v_1}^*} - \psi_{v_1}(\xi_{v_1}, \eta_{v_1}) \right] = 0,$$

along the path $x = \bar{\xi}_{v_1} \delta_{x,v_1} / \bar{\delta}_{x,v_1}$, $y = \bar{\eta}_{v_1} \delta_{y,v_1} / \bar{\delta}_{y,v_1}$, where

$\delta_{x,v_1}^{(q)} \ll \bar{\delta}_{x,v_1} < 1$, $\delta_{y,v_1}^{(q)} \ll \bar{\delta}_{y,v_1} < 1$. Moreover, it follows from theorem

5.2 that the limit

$$(5.14) \quad \lim_{\bar{\xi}_{v_2}, \bar{\eta}_{v_2}} \left[\frac{\phi}{\delta_{v_2}^*} - \psi_{v_2}(\xi_{v_2}, \eta_{v_2}) \right] = 0$$

converges uniformly along the path $x = \bar{\xi}_{v_2} \delta_{x,v_2} / \bar{\delta}_{x,v_2}$,

$y = \bar{\eta}_{v_2} \delta_{y,v_2} / \bar{\delta}_{y,v_2}$, where $\delta_{x,v_2}^{(q)} \ll \bar{\delta}_{x,v_2} < 1$, $\delta_{y,v_2}^{(q)} \ll \bar{\delta}_{y,v_2} < 1$.

The pair of order functions $\{\hat{\delta}_{x,v}(\varepsilon), \hat{\delta}_{y,v}(\varepsilon)\}$ is required to satisfy two conditions.

The first condition is that $\hat{\delta}_{x,v}$ and $\hat{\delta}_{y,v}$ must be of an order of magnitude sufficiently close to 0(1) so that (5.13) and (5.14) can have a common path for their limits. The second condition will be established later.

Let $x = \xi_{\mu} \delta_{x,\mu}$, $y = \eta_{\mu} \delta_{y,\mu}$ be such a common path. This means that

$\delta_{x,\mu} = \delta_{x,v_1} \bar{\delta}_{x,v_1} = \delta_{x,v_2} / \bar{\delta}_{x,v_2}$, $\delta_{y,\mu} = \delta_{y,v_1} \bar{\delta}_{y,v_1} = \delta_{y,v_2} / \bar{\delta}_{y,v_2}$, and

that (5.13) and (5.14) can be transformed into

$$(5.15) \quad \lim_{\xi_{\mu}, \eta_{\mu}} \left[\frac{\phi}{\delta_{v_1}^*} - \psi_{v_1}(\xi_{\mu} \bar{\delta}_{x,v_1}, \eta_{\mu} \bar{\delta}_{y,v_1}) \right] = 0,$$

$$(5.16) \quad \lim_{\xi_{\mu}, \eta_{\mu}} \left[\frac{\phi}{\delta_{v_2}^*} - \psi_{v_2}(\xi_{\mu} / \bar{\delta}_{x,v_2}, \eta_{\mu} / \bar{\delta}_{y,v_2}) \right] = 0.$$

Thus $\phi(x,y;\varepsilon)$ is locally approximated by two limit functions (see the beginning of this section)

$$(5.17) \quad \phi(x, y; \varepsilon) = \psi_{\nu_1}(\xi_{\mu} \bar{\delta}_{x, \nu_1}, \eta_{\mu} \bar{\delta}_{y, \nu_1}) \delta_{\mu}^* \frac{\delta_{\nu_1}^*}{\delta_{\mu}^*} + o(\delta_{\nu_1, \mu}^{(r)} \delta_{\nu_1}^*),$$

$$(5.18) \quad \phi(x, y; \varepsilon) = \psi_{\nu_2}(\xi_{\mu} / \bar{\delta}_{x, \nu_2}, \eta_{\mu} \bar{\delta}_{y, \nu_2}) \delta_{\mu}^* \frac{\delta_{\nu_2}^*}{\delta_{\mu}^*} + o(\delta_{\nu_2, \mu}^{(r)} \delta_{\nu_2}^*).$$

When the pair of order functions $\{\hat{\delta}_{x, \nu}, \hat{\delta}_{y, \mu}\}$ is chosen such that

$$\lim_{\varepsilon \rightarrow 0} \delta_{\nu, \mu}^{(r)} \frac{\delta_{\nu_1}^*}{\delta_{\mu}^*} = 0, \quad \lim_{\varepsilon \rightarrow 0} \delta_{\nu_2, \mu}^{(r)} \frac{\delta_{\nu_2}^*}{\delta_{\mu}^*} = 0,$$

(5.17) and (5.18) turn out to be equivalent to

$$\lim_{\xi_{\mu}, \eta_{\mu}} \left[\frac{\phi}{\delta_{\mu}^*} - \frac{\delta_{\nu_1}^*}{\delta_{\mu}^*} \psi_{\nu_1}(\xi_{\mu} \bar{\delta}_{x, \nu_1}, \eta_{\mu} \bar{\delta}_{y, \nu_1}) \right] = 0$$

and

$$\lim_{\xi_{\mu}, \eta_{\mu}} \left[\frac{\phi}{\delta_{\mu}^*} - \frac{\delta_{\nu_2}^*}{\delta_{\mu}^*} \psi_{\nu_2}(\xi_{\mu} / \bar{\delta}_{x, \nu_2}, \eta_{\mu} \bar{\delta}_{y, \nu_2}) \right] = 0,$$

(see lemma 2.2). Relation (5.12) follows straight away from these limits.

Finally, we remark that matching of ψ_{ν_1} and ψ_{ν_2} is also possible, if $\delta_{x, \nu_1} \ll \delta_{x, \nu_2}$ and $\delta_{y, \nu_2} \ll \delta_{y, \nu_1}$. In such a case we have to study non-uniform convergence near $(R, 0)$ and $(0, R)$. Evidently, the fact that a similar result can be obtained is quite trivial.

The reader will have observed that so far the theory of this chapter exposed a great resemblance with the theory of non-uniform convergence in one variable. One would expect no difficulties in continuing the analogy. However, in this section we will encounter some new aspects. By giving three examples of functions with a different asymptotic behaviour we show one of the problems we deal with. It concerns the eventual freedom to se-

lect a path inside the common domain of convergence of two limits. It appears that for matching purposes only a restricted set of paths has to be considered.

Definition 5.2 A limit function ψ_ν is contained in a limit function ψ_n , if

$$\lim_{\xi_\nu, \eta_\nu} \psi_n \left(\xi_\nu \frac{\delta_{x,\nu}}{\delta_{x,n}}, \eta_\nu \frac{\delta_{y,\nu}}{\delta_{y,n}} \right) \frac{\delta_n^*(\epsilon)}{\delta_\nu^*(\epsilon)} = \psi_\nu(\xi_\nu, \eta_\nu).$$

Definition 5.3 A limit function $\psi_a(\xi_a, \eta_a)$ is called significant, if ψ_a is contained in no other limit function.

Example 5.2

$$\phi(x, y; \epsilon) = \frac{1+y+x^2}{x+y^2+\epsilon}.$$

Taking the limit $\epsilon \rightarrow 0$ along a path

$$x = \xi \delta_x, \quad y = \eta \delta_y, \quad \delta_x, \delta_y \ll 1,$$

yields the limit functions

Table III

	$\psi(\xi, \eta)$	$\delta_x \ll \epsilon$	$\delta_y \ll \epsilon$
a	$(1+\eta+\xi^2)/(\xi+\eta^2)$	1	1
b	$1/(\xi+\eta^2)$	δ_y^2	$\sqrt{\epsilon} \ll \delta_x \ll 1$ $\epsilon \ll \delta_y \ll 1$
c	$1/(\xi+\eta^2+1)$	ϵ	$\sqrt{\epsilon}$
d	$1/\epsilon$	$\epsilon \ll \delta_x \ll 1$ $\epsilon \ll \delta_y \ll 1$	$\delta_y \ll \sqrt{\delta_x}$
e	$1/\eta^2$	$\delta_x \ll \delta_y^2$ $\epsilon \ll \delta_y \ll 1$	$\sqrt{\epsilon} \ll \delta_x \ll 1$ $\epsilon \ll \delta_y \ll 1$

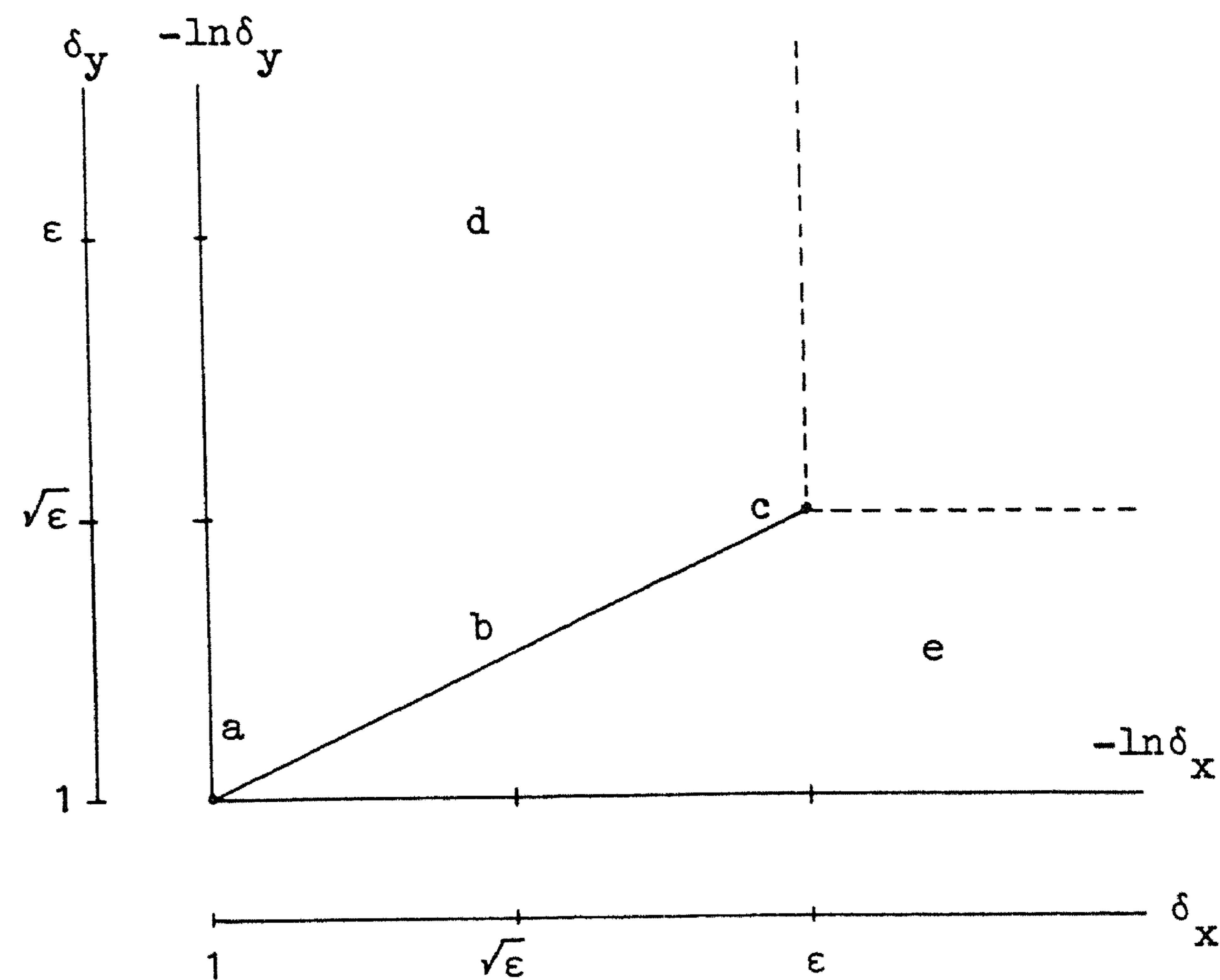

fig. 5.1

It is interesting to verify the validity of matching theorem 5.3 for the limit functions a and c. The paths corresponding with b, d and e lie in the domain of convergence of both the limit of a and the limit of c. Notice that it is sufficient to verify the matching condition for the paths of b, because the limit functions of d and e are contained in the limit function of b. The values of the order functions are brought in a diagram, see figure 5.1.

Example 5.3 Just to show that a function with a different behaviour is treated in a same manner we mention the function

$$\phi(x,y;\epsilon) = y \ln(x+\epsilon) + x + \epsilon$$

Table IV

	$\psi(\xi, \eta)$	$\delta_x = \bar{\alpha} s$	$\delta_y = \bar{\alpha} s$
a	$\eta \ln \xi + \xi$	1	1
b	$-\eta + \xi$	$\epsilon \ll \delta_x \ll 1$ $\bar{\alpha} s$	$-\delta_x / \ln \delta_x$
c	$-\eta + \xi + 1$	ϵ	$-\epsilon / \ln \epsilon$
d	ξ	$\epsilon \ll \delta_x \ll 1$ $\bar{\alpha} s$	$\delta_y \ll -\delta_x / \ln \delta_x$ $\bar{\alpha} s$
e	$-\eta$	$-\delta_x / \ln \delta_x \ll \delta_y$ $\bar{\alpha} s$	$-\epsilon / \ln \epsilon \ll \delta_y \ll 1$ $\bar{\alpha} s$

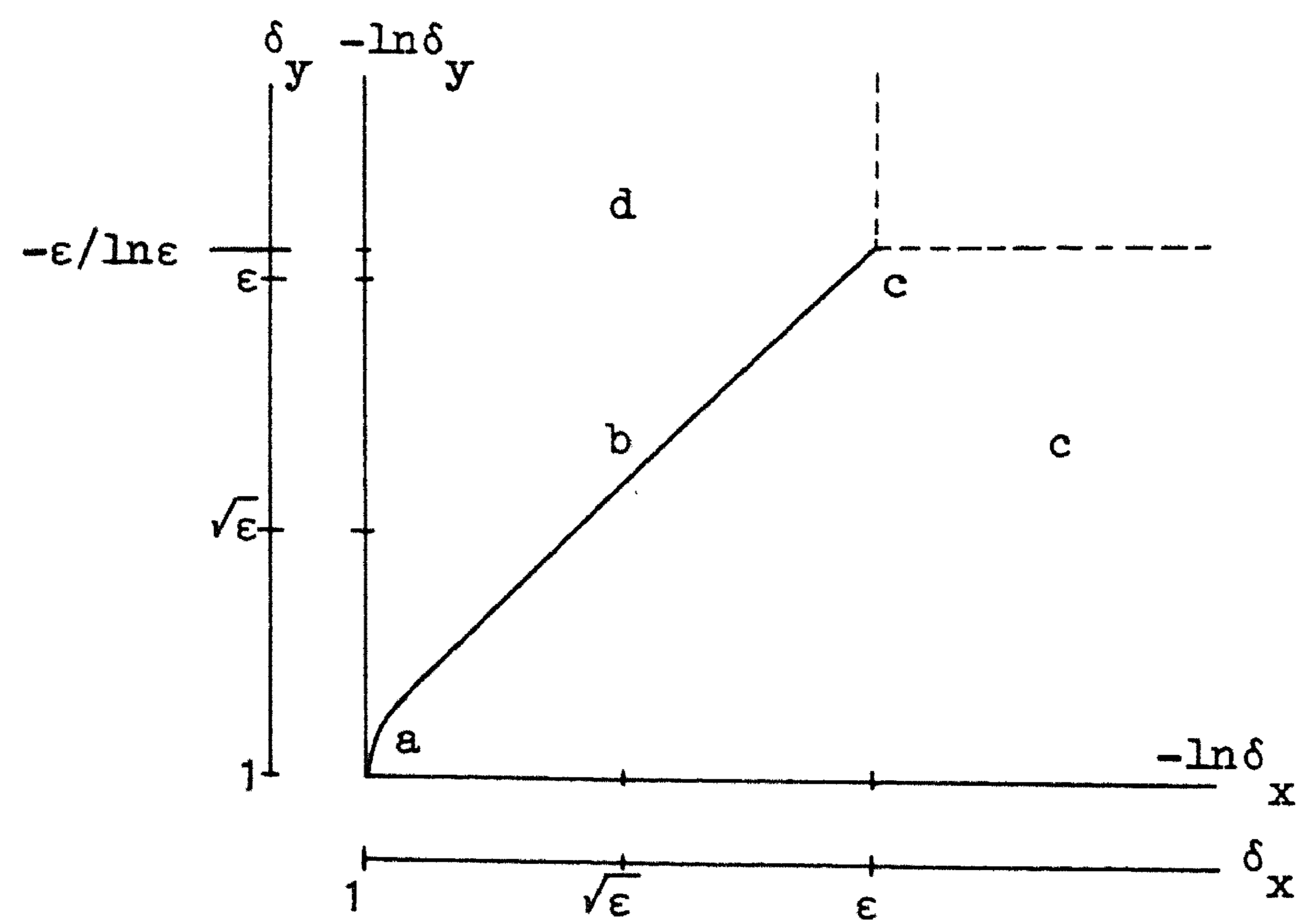

fig. 5.2

Example 5.4 In this example no special set of limit functions exists in the common domain of convergence.

$$\phi(x,y;\epsilon) = (x+2) + e^{-\frac{(x+y)}{2\epsilon}}$$

Table V

	$\psi(\xi,\eta)$	$\delta_x \xrightarrow{as}$	$\delta_y \xrightarrow{as}$
a	$\xi+2$	1	1
b	2	$\epsilon \ll \delta_x \ll 1$ as	or $\epsilon \ll \delta_y \ll 1$ as
c	$2+\exp\{-(\xi+\eta)\}$	ϵ	ϵ

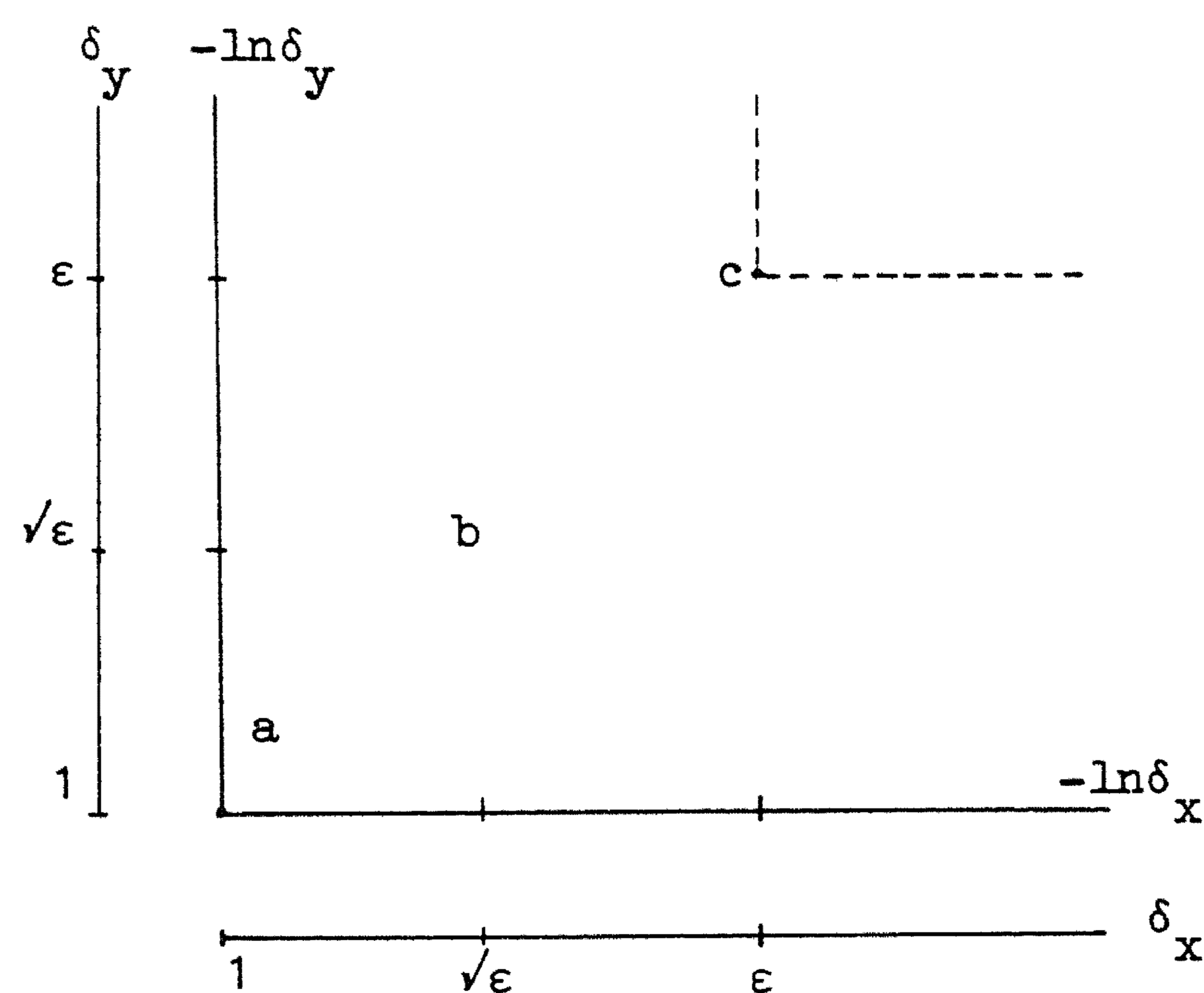

fig. 5.3

The first two examples have an analogous configuration of limit functions. We distinguish

1. two significant limit functions ψ_a, ψ_c of which the corresponding limits have a common domain of uniform convergence.

2. a set of identical limit functions ψ_{v_b} , which are contained in both ψ_a and ψ_c . The set of paths $x = \xi_{v_b} \delta_{x,v_b}$, $y = \eta_{v_b} \delta_{y,v_b}$ is continuous in v_b and $\lim_{v_b \rightarrow a} \delta_{s,v_b} = \delta_{s,a}$, $\lim_{v_b \rightarrow c} \delta_{s,v_b} = \delta_{s,b}$ for $s = x,y$.
3. two sets of identical limit functions ψ_{v_d} , ψ_{v_e} , which are contained in ψ_{v_b} .

The configuration of limit functions of the last example can be considered as a special case of the above configuration. In the sequel we will interpret such a special configuration, as being composed of the three types of limit functions mentioned above.

The existence of such a configuration is ascribed to the following property of limit functions. Let the asymptotic behaviour of a limit function $\psi_h(\xi_h, \eta_h)$ be

$$\psi_h(\xi_h, \eta_h) \approx R(\xi_h, \eta_h)$$

for $0 < \xi_h \ll 1$ and $\eta_h/f(\xi_h) = 0(1)$ with respect to ξ_h , where the function $f(\xi)$ is required to have the properties of an order function. If the path $x = \xi_v \delta_{x,h} \bar{\delta}_{x,v}$, $y = \eta_v \delta_{y,h} \bar{\delta}_{y,v}$ lies in the domain of convergence of the limit of ψ_h , and if $\bar{\delta}_{y,v}(\epsilon) \equiv f(\bar{\delta}_{x,v}(\epsilon))$, then

$$\psi_v(\xi_v, \eta_v) = R(\xi_v, \eta_v),$$

or in terms of definition 5.2: ψ_v is contained in ψ_h . A same type of argument holds for $\xi \gg 1$.

Returning to our examples we consider the set of limit functions ψ_{v_b} , of which the paths $x = \xi_{v_b} \delta_{x,v_b}$, $y = \eta_{v_b} \delta_{y,v_b}$ are chosen such that

$$\delta_{y,v_b}(\epsilon) \equiv f(\delta_{x,v_b}(\epsilon)),$$

where f follows from

$$\delta_{y,c}(\varepsilon) \equiv f(\delta_{x,c}(\varepsilon)).$$

From the foregoing we deduce that generally the limit functions ψ_{v_b} satisfy

$$\psi_{v_b}(\xi_{v_b}, \eta_{v_b}) = \psi_b(\xi_{v_b}, \eta_{v_b})$$

as far as the corresponding paths lie in the domain of convergence of the limit of ψ_a , and that

$$\psi_a(\xi_a, \eta_a) \approx \psi_b(\xi_a, \eta_a)$$

for $0 < \xi_a \ll 1$ and $\eta_a/f(\xi_a) = O(1)$ with respect to ξ_a . Likewise we have that

$$\psi_c(\xi_c, \eta_c) \approx \psi_b(\xi_c, \eta_c)$$

for $\xi_c \gg 1$ and $\eta_c/f(\xi_c) = O(1)$ with respect to ξ_c .

Thus, ψ_b is contained in both ψ_a and ψ_c .

Notice that all limit functions of the common domain of convergence are contained in ψ_b .

In theorem 5.4 these properties will be proved for the general case. We then consider the significant limit functions $\psi_a(\xi_a, \eta_a)$ and $\psi_b(\xi_b, \eta_b)$ satisfying

$$(5.23) \quad \lim_{\xi_a, \eta_a} \left[\frac{\phi(x, y; \varepsilon)}{\delta_a^*(\varepsilon)} - \psi_a(\xi_a, \eta_a) \right] = 0,$$

and

$$(5.24) \quad \lim_{\xi_c, \eta_c} \left[\frac{\phi(x, y; \varepsilon)}{\delta_c^*(\varepsilon)} - \psi_c(\xi_c, \eta_c) \right] = 0,$$

where in (5.23) $x = \xi_a \delta_{x,a}$, $y = \eta_a \delta_{y,a}$, and in (5.24) $x = \xi_c \delta_{x,c}$, $y = \eta_c \delta_{y,c}$, $\delta_{x,c} = \delta_{x,a} \bar{\delta}_{x,b}$, $\delta_{y,c} = \delta_{y,a} \bar{\delta}_{y,b}$ ($\bar{\delta}_{x,b} \ll 1$, $\bar{\delta}_{y,b} \ll 1$).

Theorem 5.4 Let for a pair of order functions $\{\delta_{x,v_b}, \delta_{y,v_b}\}$ the corresponding limit function ψ_{v_b} satisfy

$$(5.25) \quad \lim_{\xi_{v_b}, \eta_{v_b}} \psi_a \left(\xi_{v_b} \frac{\delta_{x,v_b}}{\delta_{x,a}}, \eta_{v_b} \frac{\delta_{y,v_b}}{\delta_{y,a}} \right) \frac{\delta_a^*}{\delta_{v_b}^*} = \psi_{v_b}(\xi_{v_b}, \eta_{v_b}) =$$

$$\lim_{\xi_{v_b}, \eta_{v_b}} \psi_c \left(\xi_{v_b} \frac{\delta_{x,v_b}}{\delta_{x,c}}, \eta_{v_b} \frac{\delta_{y,v_b}}{\delta_{y,c}} \right) \frac{\delta_c^*}{\delta_{v_b}^*},$$

where $\bar{\delta}_{x,b} \ll \delta_{x,v_b} \ll 1$, $\bar{\delta}_{y,b} \ll \delta_{y,v_b} \ll 1$ and

and $\bar{\delta}_{x,b}^{-1}(\delta_{x,v_b}(\varepsilon)) \equiv \bar{\delta}_{y,b}^{-1}(\delta_{y,v_b}(\varepsilon))$.

Then for any path $x = \xi_v \delta_{x,v}$, $y = \eta_v \delta_{y,v}$ in the common domain of convergence of (5.23) and (5.24)

$$\lim_{\xi_v, \eta_v} \psi_a \left(\xi_v \frac{\delta_{x,v}}{\delta_{x,a}}, \eta_v \frac{\delta_{y,v}}{\delta_{y,a}} \right) \frac{\delta_a^*}{\delta_v^*} = \lim_{\xi_v, \eta_v} \psi_c \left(\xi_v \frac{\delta_{x,v}}{\delta_{x,c}}, \eta_v \frac{\delta_{y,v}}{\delta_{y,c}} \right) \frac{\delta_c^*}{\delta_v^*}.$$

Remark The theorem is also valid, when $\delta_{x,a} = \delta_{x,c} \bar{\delta}_{x,b}$, $\delta_{y,c} = \delta_{y,a} \bar{\delta}_{y,b}$, and when $\bar{\delta}_{x,b} \bar{a}s 1$ or $\bar{\delta}_{y,b} \bar{a}s 1$.

Proof The proof of this theorem is considered to be completed, when it is demonstrated that all limit functions in the common domain of convergence are contained in ψ_{v_b} .

Let $x = \xi_{v_d} \delta_{x,v_d}$, $y = \eta_{v_d} \delta_{y,v_d}$ be an arbitrary path (not belonging to the set of paths $(\delta_{x,v_b}, \delta_{y,v_b})$) in the common domain of convergence of (5.23) and (5.25). Moreover, let the following limit exist

$$(5.26) \quad \lim_{\xi_{v_d}, \eta_{v_d}} \left| \frac{\phi(x,y;\varepsilon)}{\delta_{v_d}^*(\varepsilon)} - \psi_{v_d}(\xi_{v_d}, \eta_{v_d}) \right| = 0.$$

Since $\psi_a(\xi_a, \eta_a) \approx \psi_{v_d}(\xi_a, \eta_a)$ for $\eta_a/f(\xi_a) = o(1)$, $0 < \xi_a \ll 1$, in which

(ξ_a) is derived from

$$\frac{\delta_{y,v_d}(\varepsilon)}{\delta_{y,a}(\varepsilon)} \equiv f\left(\frac{\delta_{x,v_d}(\varepsilon)}{\delta_{x,a}(\varepsilon)}\right),$$

It is easily deduced, that other paths satisfying (5.27) generate a same function $\psi_{v_d}(\xi_{v_d}, \eta_{v_d}) = \psi_d(\xi_{v_d}, \eta_{v_d})$, as far as these paths lie in the region of convergence of (5.23).

Using with the limit function ψ_c a same argument can be applied. This

results in an equality of all limit functions, of which the order functions

are situated at one side of the set of order functions $\{\psi_{y,v_b}\}$, as it is shown in figure 5.4. For the other side we have $\psi_e(\xi_{v_e}, \eta_{v_e}) = \psi_e(\xi_{v_e}, \eta_{v_e})$.

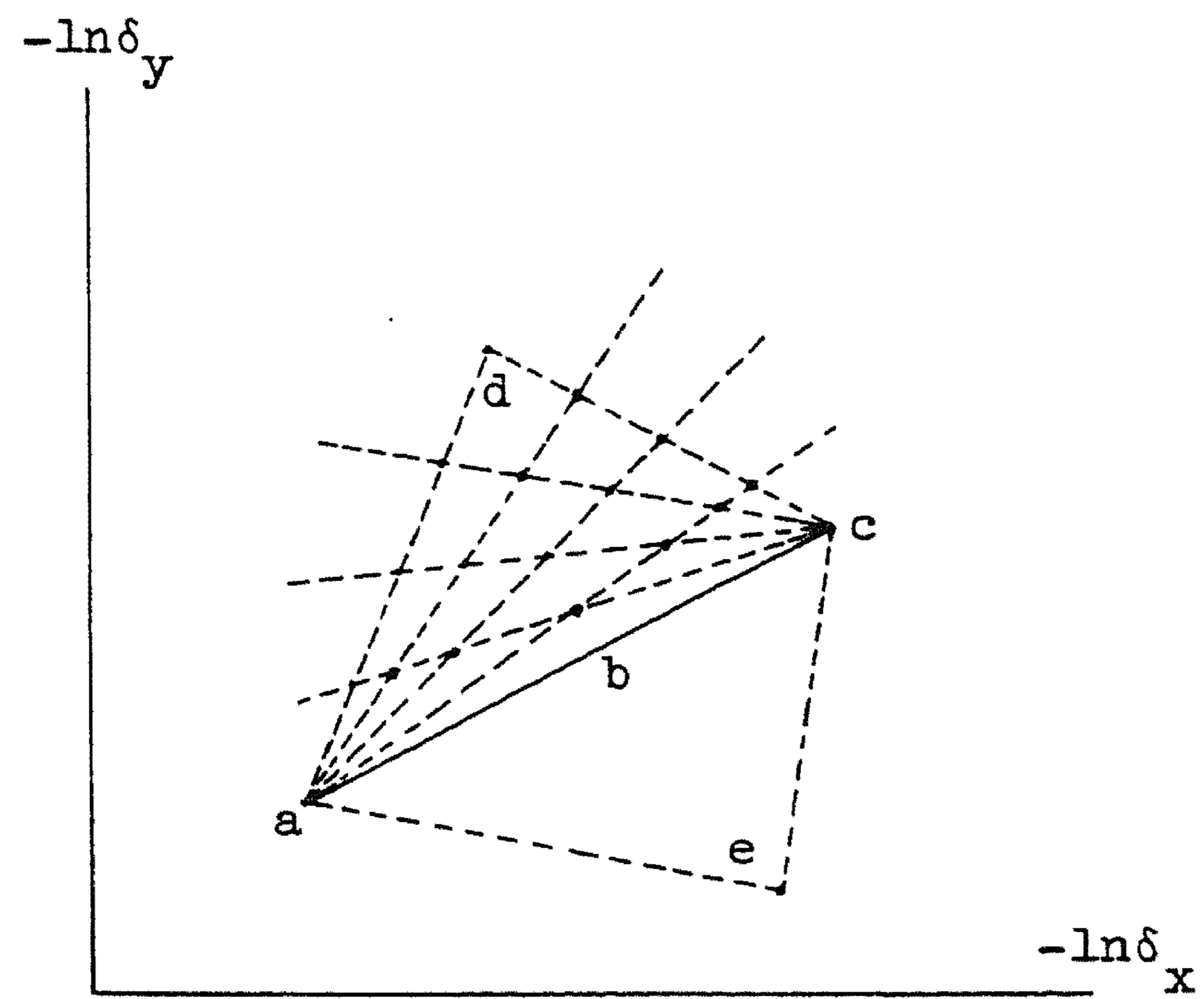

fig. 5.4

Application of theorem 5.3 for two limit functions ψ_{v_b} and ψ_{v_d} yields relations (1) and (2):

$$\lim_{\xi_{\mu_d}, \eta_{\mu_d}} \psi_{v_b} \left(\xi_{\mu_d} \frac{\delta_{x, \mu_d}}{\delta_{x, v_b}}, \eta_{\mu_d} \frac{\delta_{y, \mu_d}}{\delta_{y, v_b}} \right) \frac{\delta_{v_b}^*}{\delta_{\mu_d}^*} = \quad (1)$$

$$\lim_{\xi_{\mu_d}, \eta_{\mu_d}} \psi_{v_d} \left(\xi_{\mu_d} \frac{\delta_{x, \mu_d}}{\delta_{x, v_d}}, \eta_{\mu_d} \frac{\delta_{y, \mu_d}}{\delta_{y, v_d}} \right) \frac{\delta_{v_d}^*}{\delta_{\mu_d}^*} = \quad (2)$$

$$\psi_{\mu_d}(\xi_{\mu_d}, \eta_{\mu_d}) = \psi_{v_d}(\xi_{\mu_d}, \eta_{\mu_d}). \quad (3)$$

From relations (2) and (3) it follows that the paths $x = \xi_{\mu_d} \delta_{x, \mu_d}$, $y = \eta_{\mu_d} \delta_{y, \mu_d}$ and $x = \xi_{v_d} \delta_{x, v_d}$, $y = \eta_{v_d} \delta_{y, v_d}$ may coincide, while (1) still remains valid. This leads to the limit

$$(5.28) \quad \lim_{\xi_{v_d}, \eta_{v_d}} \psi_{v_b} \left(\xi_{v_d} \frac{\delta_{x, v_d}}{\delta_{x, v_b}}, \eta_{v_d} \frac{\delta_{y, v_d}}{\delta_{y, v_b}} \right) \frac{\delta_{v_b}^*}{\delta_{v_d}^*} = \psi_{v_d}(\xi_{v_d}, \eta_{v_d}).$$

Likewise it is shown that ψ_{v_e} is contained in ψ_{v_b} .

Theorems 5.3 and 5.4 are of great value in singular perturbation computations. By these theorems the verification of the validity of the matching principle is simplified. It is no longer necessary to take limit (5.12) for all paths in the common domain of convergence. It will be sufficient to take one path (5.25). Another consequence is that for implicitly defined functions unknown constants are completely determined by relations of the type (5.25), as we will see in chapter 6.

5.5 LOCAL AND UNIFORM ASYMPTOTIC APPROXIMATIONS

We now come to the construction of an approximation. Non-uniform convergence in both one and two variables will be studied. We distinguish three types of domains in which a limit may converge non-uniformly:

$$G_1 = \{x, y: 0 < x < R, 0 < y < R\}$$

$$G_2 = \{x, y: 0 < x < R, 0 < y < R\}$$

$$G_3 = \{x, y: 0 < x < R, 0 < y < R, (x, y) \neq (0, 0)\}.$$

Moreover, the following sequence of open domains $\{G_{i, A_n}\}$ is introduced:

$$G_{i, A_1} \supset G_{i, A_2} \supset \dots \supset G_{i, A_n} \supset \dots,$$

$$G_{i, A_n} = \bar{G}_i - G_i + S_{i, A_n}, \quad \lim_{n \rightarrow \infty} S_{i, A_n} = \emptyset.$$

The limit

$$(5.29) \quad \lim_{\varepsilon \rightarrow 0} [\phi(x, y; \varepsilon) - \omega(x, y)] = 0$$

converges non-uniformly in G_i and uniformly in $\bar{G}_i - G_{i, A_n}$ for any n . Using definition 5.1 we obtain a limit function ψ_v that satisfies

$$(5.30) \quad \lim_{\xi_v, \eta_v} \left[\frac{\phi(x, y; \varepsilon)}{\delta_v^*(\varepsilon)} - \psi_v(\xi_v, \eta_v) \right] = 0,$$

$$(5.31) \quad x = \xi_v \delta_{x, v}, \quad y = \eta_v \delta_{y, v}, \quad \delta_{x, v} \leq 1, \quad \delta_{y, v} \leq 1.$$

Application of theorem 5.1 yields bounds for the paths (5.31) along which (5.29) converges uniformly:

$$(5.32) \quad \delta_{x,0,v_1}^{(q)} \ll \delta_{x,v} < 1, \quad \delta_{y,0,v_1}^{(q)} \ll \delta_{y,v} < 1,$$

where $x = \delta_{x,0,v_1}^{(q)}(\varepsilon)$, $y = \delta_{y,0,v_1}^{(q)}(\varepsilon)$ satisfy $\delta_{x,v}^{-1}(x) = \delta_{y,v}^{-1}(y)$ and $\varepsilon = \varepsilon_0^{(q)}(x,y)$ of theorem 5.1. Since (5.29) converges uniformly along these paths, the corresponding limit functions can also be derived from $\omega(x,y)$

$$(5.33) \quad \lim_{\xi_v, \eta_v} \left[\frac{\omega(x,y)}{\delta_v^*(\varepsilon)} \right] = \psi_v(\xi_v, \eta_v).$$

It is assumed that the set of order functions $\{\delta_{x,0,v_1}^{(q)}, \delta_{y,0,v_1}^{(q)}\}$ contains a finite number of order functions

$$(5.34) \quad \{\delta_{x,0,v_{1k}}^{(q)}, \delta_{y,0,v_{1k}}^{(q)}\}, \quad k = 1, 2, \dots, k_1,$$

for which the limit functions $\psi_{1k}(\xi_{1k}, \eta_{1k})$, satisfying

$$(5.35) \quad \lim_{\xi_{1k}, \eta_{1k}} \left[\frac{\phi(x,y;\varepsilon)}{\delta_{1k}^*(\varepsilon)} - \psi_{1k}(\xi_{1k}, \eta_{1k}) \right] = 0,$$

$$(5.36) \quad x = \xi_{1k} \delta_{x,1k}, \quad y = \eta_{1k} \delta_{y,1k}, \quad \delta_{x,1k} \approx \delta_{x,0,v_{1k}}^{(q)}, \quad \delta_{y,1k} = \delta_{y,0,v_{1k}}^{(q)},$$

are significant limit functions.

Let the set of order functions $\{\delta_{x,0,v_{1k}}, \delta_{y,0,v_{1k}}\}$ satisfy

$$(5.37) \quad \delta_{y,0,v_{1k}}(\varepsilon) \equiv f_{01,1k}(\delta_{x,0,v_{1k}}(\varepsilon)),$$

where the function $f_{01,1k}$ is determined by the relation

$$\delta_{y,1k}(\varepsilon) \equiv f_{01,1k}(\delta_{x,1k}(\varepsilon)).$$

The corresponding paths of $\{\delta_{x,0,v_{1k}}, \delta_{y,0,v_{1k}}\}$ have to lie in the extended domain of uniform convergence of both (5.30) and (5.35). The corresponding limit functions are one and the same function $\psi_{0,v_{1k}}$. Application of theorems 5.3 and 5.4 yields

$$(5.38) \quad \lim_{\xi_{0,v_{1k}}, \eta_{0,v_{1k}}} \left[\frac{\omega(\xi_{0,v_{1k}} \frac{\delta_{x,0,v_{1k}}}{\delta_{x,0,v_{1k}}}, \eta_{0,v_{1k}} \frac{\delta_{y,0,v_{1k}}}{\delta_{y,0,v_{1k}}})}{\delta_{0,v_{1k}}^*} \right] =$$

$$\psi_{0,v_{1k}}(\xi_{0,v_{1k}}, \eta_{0,v_{1k}}) =$$

$$\lim_{\xi_{0,v_{1k}}, \eta_{0,v_{1k}}} \left[\psi_{1k} \left(\xi_{0,v_{1k}} \frac{\delta_{x,0,v_{1k}}}{\delta_{x,1k}}, \eta_{0,v_{1k}} \frac{\delta_{y,0,v_{1k}}}{\delta_{y,1k}} \right) \frac{\delta_{1k}^*}{\delta_{0,v_{1k}}^*} \right].$$

From practical point of view it would be convenient to choose an ordered numbering of the significant limit functions. Considering $y = f_{0,1k}(x)$ as an order function we decide that for $0 < x \ll 1$

$$f_{0,1k}(x) \underset{\text{as}}{\ll} f_{0,1l}(x), \quad \text{if and only if } k > l.$$

As we made the assumption (in the foregoing section) that every set of bounding order functions $\{\delta_x^{(q)}, \delta_y^{(q)}\}$ has to consist of asymptotically equal order functions for all q , the extended domains of convergence of (5.35) will overlap for $k = k^*$ and $k = k^* + 1$ ($1 \leq k^* \leq k_1 - 1$). The matching condition in the form of theorems 5.3 and 5.4 leads to the relation

$$\lim_{\xi_{1,\mu_k}, \eta_{1,\mu_k}} \left[\psi_{1k} \left(\xi_{1,\mu_k} \frac{\delta_{x,1,\mu_k}}{\delta_{x,1k}}, \eta_{1,\mu_k} \frac{\delta_{y,1,\mu_k}}{\delta_{y,1k}} \right) \frac{\delta_{1k}^*}{\delta_{1,\mu_k}^*} \right] =$$

$$\psi_{1,\mu_k}(\xi_{1,\mu_k}, \eta_{1,\mu_k}) =$$

$$\lim_{\xi_{1,\mu_k}, \eta_{1,\mu_k}} \left[\psi_{1k^+} \left(\xi_{1,\mu_k} \frac{\delta_{x,1,\mu_k}}{\delta_{x,1k^+}}, \eta_{1,\mu_k} \frac{\delta_{y,1,\mu_k}}{\delta_{y,1k^+}} \right) \frac{\delta_{1k^+}^*}{\delta_{1,\mu_k}^*} \right],$$

$$k^+ = k+1, \quad 1 \leq k \leq k_1 - 1,$$

where the path

$$(5.39) \quad x = \xi_{1,\mu_k} \delta_{x,1,\mu_k}, \quad y = \eta_{1,\mu_k} \delta_{y,1,\mu_k},$$

lies in the common domain of convergence. The order functions satisfy

$$\frac{\delta_{y,1,\mu_k}(\varepsilon)}{\delta_{y,1k}(\varepsilon)} \equiv g_{1k} \left(\frac{\delta_{x,1,\mu_k}(\varepsilon)}{\delta_{x,1k}(\varepsilon)} \right),$$

where the function g_{1k} follows from the relation

$$\frac{\delta_{y,1k^+}(\varepsilon)}{\delta_{y,1k}(\varepsilon)} \equiv g_{1k} \left(\frac{\delta_{x,1k^+}(\varepsilon)}{\delta_{x,1k}(\varepsilon)} \right).$$

It can be shown that the order functions of (5.39) belong to the set of bounding order functions $\delta_{x,0,\nu_1}^{(q)}$, $\delta_{y,0,\nu_1}^{(q)}$ of (5.32). Application of the extension theorems to (5.35) yields the set of bounding order functions

$$\{\delta_{x,1,\nu_k}^{(q)}, \delta_{y,1,\nu_k}^{(q)}\}.$$

Let there be k_2 order functions $\{\delta_{x,1,\nu_{kl}}^{(q)}, \delta_{y,1,\nu_{kl}}^{(q)}\}$ ($\neq \{\delta_{x,1m}, \delta_{y,1m}\}, m=1, \dots, k_1$) of which the limit functions, say

$\psi_{2l}(\xi_{2l}, \eta_{2l})$, $l = 1, \dots, k_2$, are significant.

For two limit functions ψ_{1k} , ψ_{2l} a matching relation can be derived, if their limits have a common domain of convergence:

$$\lim_{\xi_{1,\nu_{kl}}, \eta_{1,\nu_{kl}}} \left[\psi_{1k} \left(\xi_{1,\nu_{kl}} \frac{\delta_{x,1,\nu_{kl}}}{\delta_{x,1k}}, \eta_{1,\nu_{kl}} \frac{\delta_{y,1,\nu_{kl}}}{\delta_{y,1k}} \right) \frac{\delta_{1k}^*}{\delta_{1,\nu_{kl}}^*} \right] =$$

$$\lim_{\xi_{1,\nu_{kl}}, \eta_{1,\nu_{kl}}} \left[\psi_{2l} \left(\xi_{1,\nu_{kl}} \frac{\delta_{x,1,\nu_{kl}}}{\delta_{x,2l}}, \eta_{1,\nu_{kl}} \frac{\delta_{y,1,\nu_{kl}}}{\delta_{y,2l}} \right) \frac{\delta_{2l}^*}{\delta_{1,\nu_{kl}}^*} \right] =$$

$$\psi_{1,v_{kl}}(\xi_{1,v_{kl}}, \eta_{1,v_{kl}}),$$

$$\delta_{y,1,v_{kl}} / \delta_{y,1k} \equiv f_{1k,2l}(\delta_{x,1,v_{kl}} / \delta_{x,1k}),$$

where $f_{1k,2l}$ is determined by the relation

$$\delta_{y,2l} / \delta_{y,1k} \equiv f_{1k,2l}(\delta_{x,2l} / \delta_{y,1k}).$$

In this way some superfluous relations may be introduced.

When of two sets of limit function $\psi_{1,v_{k_a l_a}}$, $\psi_{1,v_{k_b l_b}}$ the paths of two samples coincide, one set is deleted, see example 5.6.

The construction of significant limit functions is proceeded until for $n = n_t$ the order functions $\{\delta_{x,n,v_k}^{(q)}, \delta_{y,n,v_k}^{(q)}\}$, $k = 1, 2, \dots, k_n$ do not correspond to a new significant limit function.

The index n of ψ_{nk} denotes a sort of boundary layer level. The function ω is a limit function at level zero and could also be written as ψ_{01} .

For any path

$$(5.40) \quad x = \xi_v \delta_{x,v}, \quad y = \eta_v \delta_{x,v}, \quad \delta_{x,v} \leq 1, \quad \delta_{y,v} \leq 1$$

a significant limit function ψ_{nk} exists such that the limit function ψ_v corresponding with (5.40) is contained in ψ_{nk} . When the path (5.40) lies in the domain of convergence of more than one limit defining a significant limit function, it is arranged that ψ_{nk} at the lowest level n is assigned to that path. If there remains more than one significant limit function, the one with the order function $\delta_{x,nk}$ or $\delta_{y,nk}$ tending to zero in the slowest manner is chosen.

Let $\psi_{n_a k_a}$ be such a significant limit function. According to (5.5ab) this limit function can be considered as a local approximation of ϕ

$$(5.41) \quad \phi(x,y;\varepsilon) = \psi_{n_a k_a}(\xi_v \frac{\delta_{x,v}}{\delta_{x,n_a k_a}}, \eta_v \frac{\delta_{y,v}}{\delta_{y,n_a k_a}}) \delta_{n_a k_a}^* + o(\delta_v^{(r)} \delta_{n_a k_a}^*).$$

Having in mind the construction of an approximation, uniformly valid in \overline{G}_i , we distinguish four types of limit functions

- a. ψ_{nk} ($k=1,2,\dots,k_n$, $n=0,1,\dots,n_t$), on level n there are k_n significant limit functions.
- b. $\psi_{n,\nu_{kl}}$ ($n=0,1,\dots,n_t-1$), between level n and $n+1$ a set of equal limit functions exist which are contained in both ψ_{nk} and ψ_{n+1} . The other limit functions defined in the common domain of convergence are contained in $\psi_{n,\nu_{kl}}$.
- c. ψ_{n,μ_k} ($n=0,1,\dots,n_t$, $k=1,2,\dots,k_n-1$) these sets of equal limit functions are contained in both ψ_{nk} and ψ_{nk+} , they have the same properties as the limit functions of b.
- d. $\psi_{n,\alpha_{kl}}$, $\psi_{n,\beta_{kl}}$ ($n=1,2,\dots,n_t-1$) the sets of paths of these limit functions are bounded by the paths of a, b and c. The differences between $\psi_{n,\alpha_{kl}}$ and $\psi_{n,\beta_{kl}}$ are shown in figure 5.5.

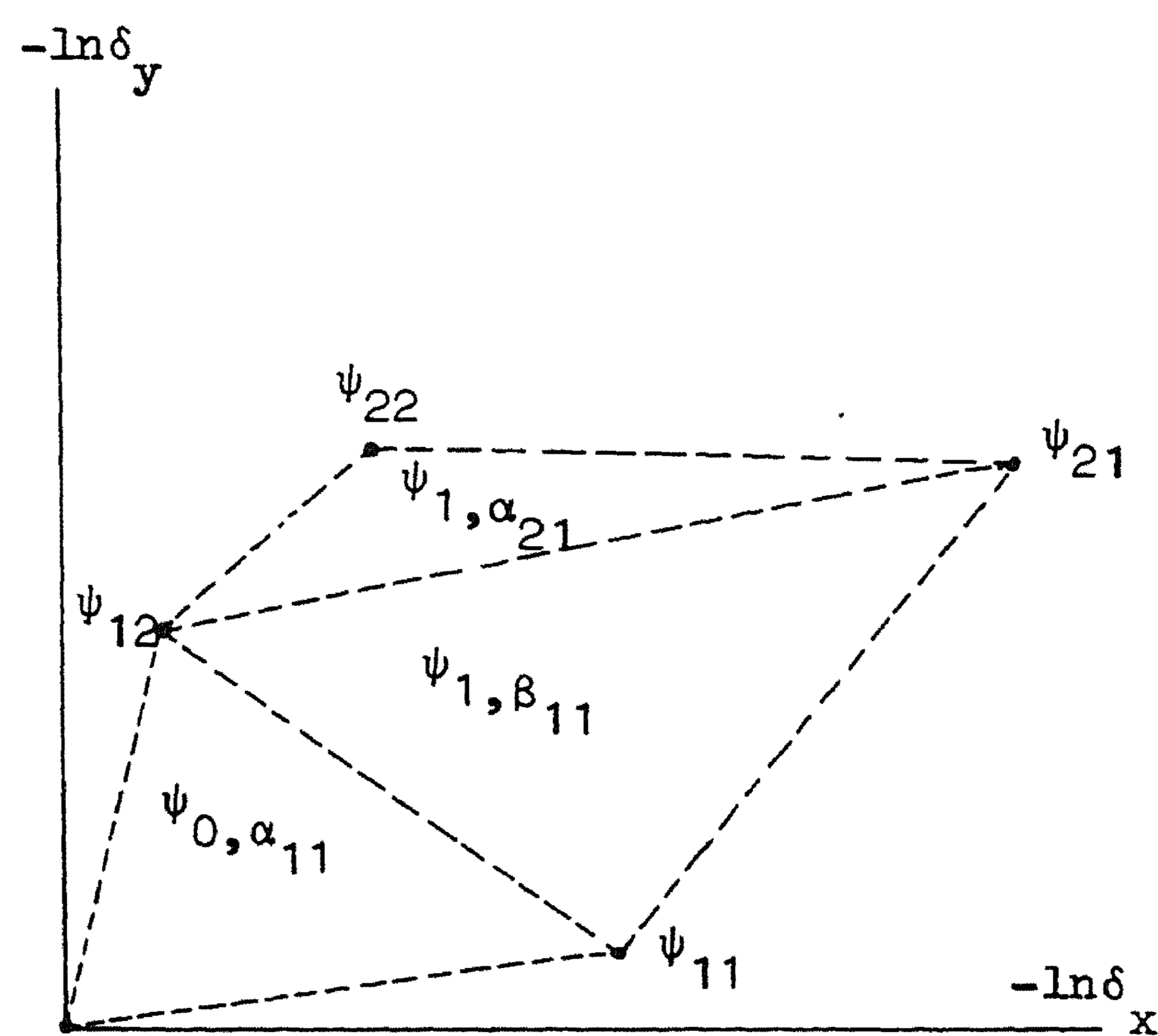

fig. 5.5

Example 5.5

$$\phi(x,y;\epsilon) = \frac{x+x^2}{x+y^2+\epsilon^2} + \frac{y+y^2}{y+x^2+\epsilon^2}$$

We introduce the transformation

$$(5.42) \quad x = \xi\epsilon^\alpha, \quad y = \eta\epsilon^\beta, \quad \alpha, \beta \geq 0,$$

and determine the limit functions belonging to the sets mentioned above. The diagram with the values of the order functions is simplified for this special case (5.42) (see figure 5.6).

Table VI

	α, β	ψ		α, β	ψ
a	$\alpha=\beta=0$	$\psi_{01} = \frac{\xi+\xi^2}{\xi+\eta^2} + \frac{\eta+\eta^2}{\eta+\xi^2}$	g	$2\alpha=\beta=2$	$\psi_{13} = 1 + \frac{\eta}{\eta+\xi^2+1}$
b	$0<\alpha=2\beta<2$	$\psi_{0,v_{11}} = \frac{\xi}{\xi+\eta^2} + 1$	h	$\alpha=2, 1<\beta<2$	$\psi_{1,\mu_1} = \frac{\xi}{\xi+1} + 1$
c	$0<\alpha=\beta<2$	$\psi_{0,v_{12}} = 2$	i	$1<\alpha<2, \beta=2$	$\psi_{1,\mu_2} = 1 + \frac{\eta}{\eta+1}$
d	$0<2\alpha=\beta<2$	$\psi_{0,v_{13}} = 1 + \frac{\eta}{\eta+\xi^2}$	j	$0<\alpha<2, \alpha<2\beta<2\alpha$	$\psi_{0,\alpha_{11}} = 2$
e	$\alpha=2\beta=2$	$\psi_{11} = \frac{\xi}{\xi+\eta^2+1} + 1$	k	$\beta<2\alpha<2\beta, 0<\beta<1$	$\psi_{0,\alpha_{12}} = 2$
f	$\alpha=\beta=2$	$\psi_{12} = \frac{\xi}{\xi+1} + \frac{\eta}{\eta+1}$			

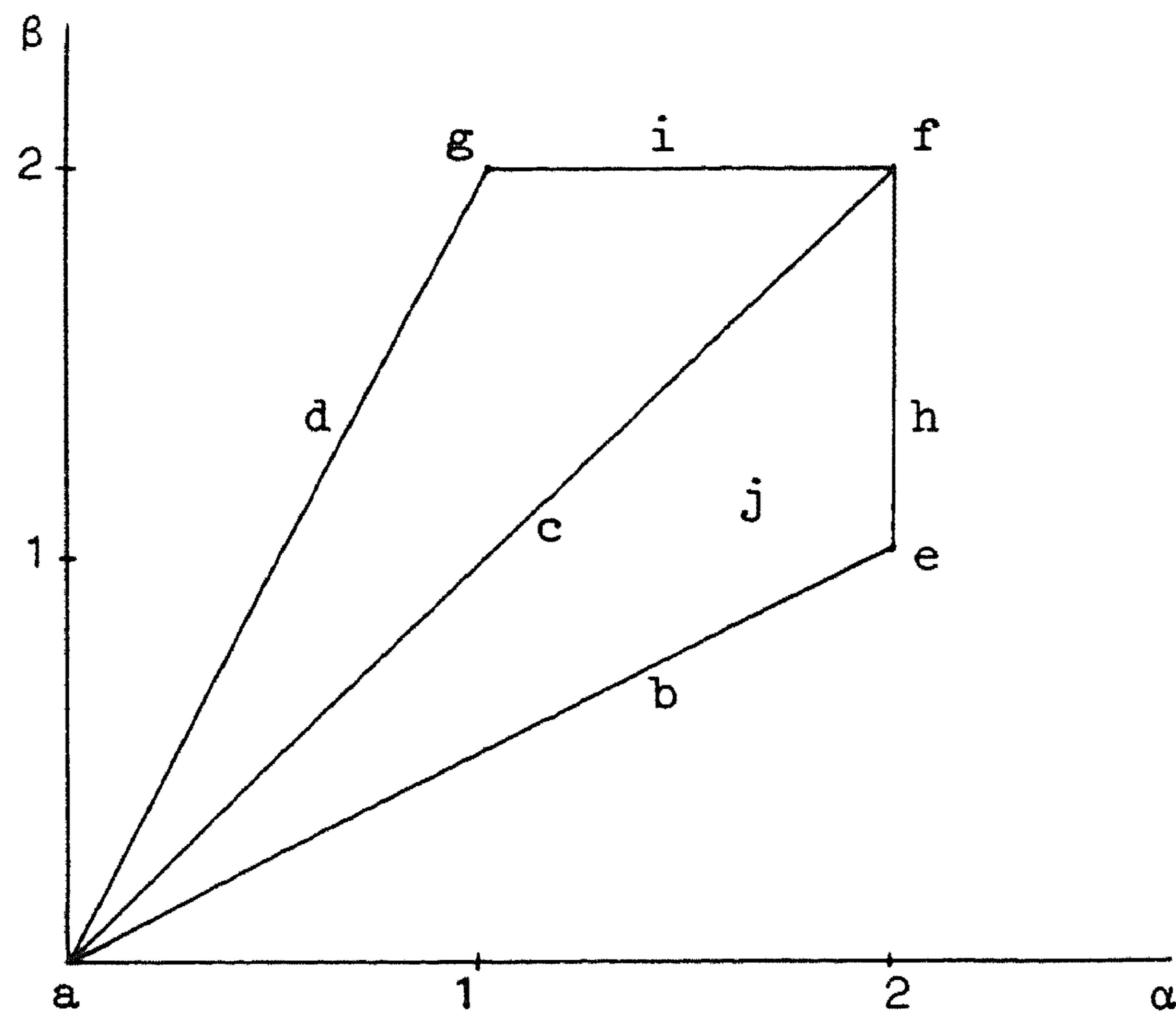

fig. 5.6

Example 5.6

$$\phi(x,y;\epsilon) = (xy+1) \{ \exp(-xy/\epsilon) + \exp(-xy/\epsilon^2) + 1 \}.$$

Here we may have two configurations (α and β are chosen as in (5.43)):

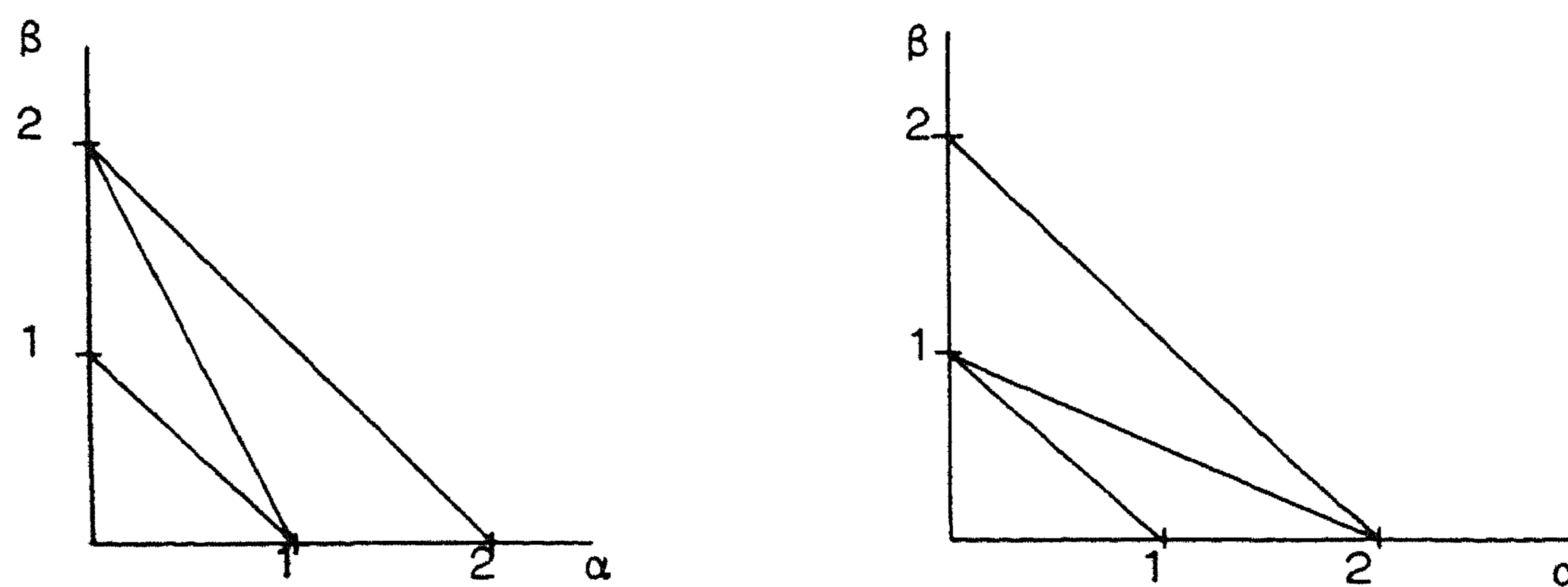

fig. 5.7

Theorem 5.5 The explicitly given function $\phi(x,y;\varepsilon)$ is approximated uniformly in \overline{G}_ε by

$$(5.44) \quad \phi_0(x,y;\varepsilon) =$$

$$\begin{aligned} &= \sum_{n=0}^{n_t} \sum_{k=1}^{k_n} \psi_{nk}(x/\delta_{x,nk}, y/\delta_{y,nk}) \delta_{nk}^*(\varepsilon) + \\ &- \sum_{n=0}^{n_t-1} \sum_{k=1}^{k_n} \sum_{l=1}^{k_{n+1}} \nabla \psi_{n,\nu_{kl}}(x/\delta_{x,n,\nu_{kl}}, y/\delta_{y,n,\nu_{kl}}) \delta_{n,\nu_{kl}}^*(\varepsilon) + \\ &- \sum_{n=1}^{n_t} \sum_{k=1}^{k_n-1} \psi_{n,\mu_k}(x/\delta_{x,n,\mu_k}, y/\delta_{y,n,\mu_k}) \delta_{n,\mu_k}^*(\varepsilon) + \\ &+ \sum_{n=1}^{n_t-1} \sum_{k=1}^{k_n} \sum_{l=1}^{k_{n+1}-1} \nabla \psi_{n,\alpha_{kl}}(x/\delta_{x,n,\alpha_{kl}}, y/\delta_{y,n,\alpha_{kl}}) \delta_{n,\alpha_{kl}}^* + \\ &+ \sum_{n=1}^{n_t-1} \sum_{k=1}^{k_n-1} \sum_{l=1}^{k_{n+1}} \nabla \psi_{n,\beta_{kl}}(x/\delta_{x,n,\beta_{kl}}, y/\delta_{y,n,\beta_{kl}}) \delta_{n,\beta_{kl}}^* , \end{aligned}$$

∇ as far as the subscripted limit functions exist.

Proof According to definition 3.1 we need to prove that

$$(5.45) \quad \lim_{(x,y;\varepsilon) \rightarrow (x_1,y_1,0)} [\phi(x,y;\varepsilon) - \phi_0(x,y;\varepsilon)] = 0, \\ 0 \leq x_1 \leq R, \quad 0 \leq y_1 \leq R,$$

independently of the path chosen in the domain

$$\overline{G}_\varepsilon = \{x,y,\varepsilon: 0 \leq x \leq R, 0 \leq y \leq R, 0 \leq \varepsilon \leq \varepsilon^*\}.$$

Firstly, the asymptotic behaviour of the significant limit functions is analyzed. Three cases are considered.

1. In ψ_{nk} the coordinates of a transformation corresponding with a significant limit function on a higher boundary layer level are substituted. Let this limit function of a higher level be connected to the limit functions ψ_{nk^e} by $\psi_{n,v_{kl}^{e_1}}, \dots$. We may have

$$\text{a. if } k = k^e \quad \psi_{nk} \delta_{nk}^* = \sum_{l=1}^{k_{n+1}} \nabla \psi_{n,v_{kl}} \delta_{n,v_{kl}}^* - \sum_{l=1}^{k_{n+1}-1} \nabla \psi_{n,\alpha_{kl}} \delta_{n,\alpha_{kl}}^*,$$

($\psi_{n,v_{kl}}$ exists)

$$\text{b. if } k \neq k^e \quad \psi_{nk} \delta_{nk}^* = \psi_{n,\mu_l} \delta_{n,\mu_l}^*, \quad l = k-1 \quad \text{for } k > k^e$$

($\psi_{n,v_{kl}}$ does not exist) $l = k \quad \text{for } k < k^e$.

2. In ψ_{nk} the coordinates of a transformation corresponding with a significant limit function ψ_{nm} on a same boundary layer level are substituted, then ψ_{nk} behaves as in (5.45), $l = k-1$ for $m < k$ and $l = k$ for $m > k$.
3. In ψ_{nk} the coordinates of a transformation corresponding with a significant function on a lower boundary layer level are substituted

$$\psi_{nk} \delta_{nk}^* = \sum_{l=1}^{k_{n-1}} \nabla \psi_{n,v_{lk}} \delta_{n,v_{lk}}^* - \sum_{l=1}^{k_{n-1}-1} \nabla \psi_{n,\beta_{lk}} \delta_{n,\beta_{lk}}^* .$$

Secondly, the asymptotic behaviour of the limit function ψ_{n,μ_k} is analyzed.

1. When the coordinates of a transformation at a higher boundary layer level are substituted

$$(5.47a) \quad \psi_{n,\mu_k} \delta_{n,\mu_k}^* = \psi_{n,\beta_{kl}} \delta_{n,\beta_{kl}}^* .$$

2. For a transformation at a lower boundary layer level it becomes

$$(5.47b) \quad \psi_{n,\mu_k} \delta_{n,\mu_k}^* = \psi_{n-1,\alpha_{lk}} \delta_{n-1,\alpha_{lk}}^* ,$$

These results enable us to prove the validity of (5.43).

Let

$$(5.48) \quad x = \xi \delta_x, \quad y = \eta \delta_y, \quad \delta_x \leq 1, \delta_y \leq 1$$

be an arbitrary path in the domain \overline{G}_ϵ . This path lies in the domain of convergence of one or more limits. One of these limits defines a significant limit function $\psi_{n_a k_a}$ in the way it is prescribed in (5.41). The asymptotic formulae for ψ_{nk} and ψ_{n, μ_k} remain the same when instead of the coordinates $\xi_{n_a k_a}, \eta_{n_a k_a}$ the coordinates ξ_ν, η_ν are substituted, so that

$$(5.49a) \quad \sum_{n=0}^{n_a-1} \sum_{k=1}^k \psi_{nk} \delta_{nk}^* = \sum_{n=0}^{n_a-1} \sum_{k=1}^k \sum_{l=1}^{k_{n+1}} \nabla \psi_{n, \nu_{kl}} \delta_{n, \nu_{kl}}^* +$$

$$+ \sum_{n=0}^{n_a-1} \sum_{k=1}^{k_n-1} \psi_{n, \mu_k} \delta_{n, \mu_k}^* +$$

$$\quad \text{if } k \neq k^e \text{ or } (k+1) \neq (k+1)^e$$

$$- \sum_{n=0}^{n_a-1} \sum_{k=1}^k \sum_{l=1}^{l_{n+1}-1} \nabla \psi_{n, \alpha_{kl}} \delta_{n, \alpha_{kl}}^*,$$

$$(5.49b) \quad \sum_{k=1}^k \psi_{n_a k} \delta_{n_a k}^* - \psi_{n_a k_a} \delta_{n_a k_a}^* = \sum_{k=1}^{k_{n-1}} \psi_{n_a, \mu_k} \delta_{n_a, \mu_k}^*,$$

$$(5.49c) \quad \sum_{n=n_a+1}^{n_t} \sum_{k=1}^k \psi_{nk} \delta_{nk}^* = \sum_{n=n_a}^{n_t-1} \sum_{k=1}^k \sum_{l=1}^{k_{n+1}} \nabla \psi_{n, \nu_{kl}} \delta_{n, \nu_{kl}}^* +$$

$$- \sum_{n=n_a}^{n_t-1} \sum_{k=1}^{k_n-1} \sum_{l=1}^{l_{n+1}} \nabla \psi_{n, \beta_{kl}} \delta_{n, \beta_{kl}}^*,$$

$$(5.49d) \quad \sum_{n=0}^{n_a-1} \sum_{k=1}^{k_n-1} \psi_{n,\mu_k} \delta_{n,\mu_k}^* = \sum_{n=0}^{n_a-1} \sum_{k=1}^{k_n-1} \sum_{l=1}^{k_{n+1}} \nabla \psi_{n,\beta_{kl}} \delta_{n,\beta_{kl}}^*,$$

if $k=k^e$ and
 $(k+1)=(k+1)^e$
if $k=k^e$ and
 $(k+1)=(k+1)^e$

$$(5.49e) \quad \sum_{n=n_a+1}^{n_t} \sum_{k=1}^{k_n-1} \psi_{n,\mu_k} \delta_{n,\mu_k}^* = \sum_{n=n_a}^{n_t-1} \sum_{k=1}^{k_n} \sum_{l=1}^{l_{n+1}-1} \nabla \psi_{n,\alpha_{kl}} \delta_{n,\alpha_{kl}}^*.$$

Thus (5.43) turns out to be true, if

$$\lim_{\xi, \eta} \left[\frac{\phi(x, y; \varepsilon)}{\delta_{n_a k_a}^*(\varepsilon)} - \psi_{n_a k_a} \left(\frac{\delta_x}{\delta_{x, n_a k_a}}, \xi, \frac{\delta_y}{\delta_{y, n_a k_a}}, \eta \right) \right] = 0.$$

This limit is valid, because the path (5.48) lies in the extended domain of uniform convergence of it.

Example 5.7

$$\phi(x, y; \varepsilon) = -1 + yx \ln(y + \varepsilon + xy\varepsilon) + \frac{(1+y)^2}{1+x\varepsilon} + \frac{y+3\varepsilon}{1+x\varepsilon} \left(e^{\frac{x \sin y \ln \varepsilon}{\varepsilon}} + e^{\frac{-y+x \ln \varepsilon}{\varepsilon}} \right).$$

The asymptotic behaviour of such a function is completely revealed, when those limit functions ψ satisfying

$$\lim_{\xi, \eta} \frac{\phi(x, y; \varepsilon)}{\delta^*(\varepsilon)} - \psi(\xi, \eta) = 0, \quad x = \xi \delta_x, \quad y = \eta \delta_y$$

$$\delta_x \lesssim 1, \quad \delta_y \lesssim 1,$$

are determined, which belong to the four types mentioned before (fig. 5.8). The uniformly valid approximation has the form

$$\begin{aligned} \phi_0(x, y; \varepsilon) = & \psi_{0,1}(x, y) + \psi_{1,1}\left(\frac{-x \ln \varepsilon}{\varepsilon}, y\right) + \varepsilon \psi_{1,2}(-x \ln \varepsilon, y/\varepsilon) + \varepsilon \psi_{2,1}(-x \ln \varepsilon/\varepsilon, y/\varepsilon) + \\ & - \psi_{0,v_{11}}(x, y) - \psi_{0,v_{12}}(x, y) - \psi_{1,\mu_1}\left(\frac{-x \ln \varepsilon}{\varepsilon}, y\right) - \varepsilon \psi_{1,v_{11}}(-x \ln \varepsilon, y/\varepsilon) + \psi_{0,\alpha_{11}}(x, y). \end{aligned}$$

This example only serves to explain the method developed in the preceding sections. The function $\phi_0(x,y;\epsilon)$ could be derived from $\phi(x,y;\epsilon)$ in an easier way.

Table VII

	$\psi(\xi,\eta)$	$\delta_x(\epsilon)$	$\delta_y(\epsilon)$
a	$\psi_{01} = \eta^2 + 2\eta + \eta\xi \ln \eta$	$\delta_{xas} = 1$	$\delta_{yas} = 1$
b	$\psi_{0,v_{11}} = \eta^2 + 2\eta$	$-\epsilon/\ln \epsilon \ll \delta_{xas} \ll 1$	$\delta_{yas} = 1$
c	$\psi_{0,v_{12}} = 2\eta + \xi\eta$	$-1/\ln \epsilon \ll \delta_{xas} \ll 1$	$\delta_{yas} = \exp(-1/\delta_x)$
d	$\psi_{11} = \eta^2 + 2\eta + \eta \exp(-\xi \sin \eta)$	$\delta_{xas} = -\epsilon/\ln \epsilon$	$\delta_{yas} = 1$
e	$\psi_{12} = 2\eta + \xi\eta + (\eta+3)\exp(-\xi\eta)$	$\delta_{xas} = -1/\ln \epsilon$	$\delta_{yas} = \epsilon$
f	$\psi_{1,\mu_1} = 2\eta + \eta \exp(-\xi\eta)$	$-\epsilon/\ln \epsilon \ll \delta_{xas} \ll -1/\ln \epsilon$	$\delta_{yas} = -\epsilon/(\delta_x \ln \epsilon)$
g	$\psi_{1,v_{11}} = 3\eta + 3$	$-\epsilon/\ln \epsilon \ll \delta_{xas} \ll -1/\ln \epsilon$	$\delta_{yas} = \epsilon$
h	$\psi_{21} = 2\eta + (\eta+3)\{1 + \exp(-\xi-\eta)\}$	$\delta_{xas} = -\epsilon/\ln \epsilon$	$\delta_{yas} = \epsilon$
i	$\psi_{0,\alpha_{11}} = 2\eta$	$-\epsilon/\delta_y \ln \epsilon \ll \delta_{xas} \ll -1/\ln \delta_y$	$\epsilon \ll \delta_{yas} \ll 1$

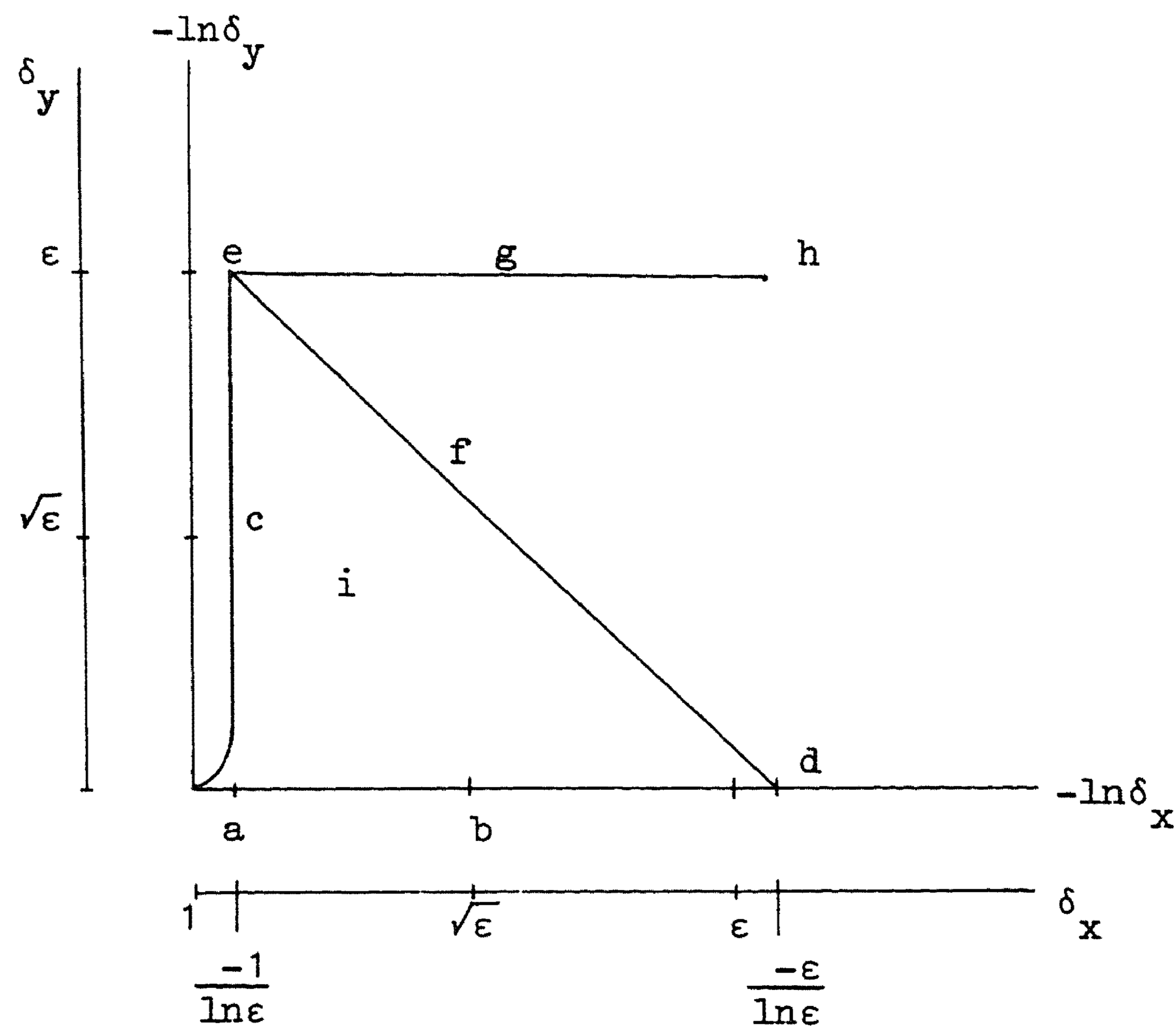

fig. 5.8

5.6 APPLICATION TO AN EXPLICITLY GIVEN FUNCTION

In order to show the advantages of the theory developed in the preceding sections an application is given. The examples previously given were more or less prefabricated. This application, however, forms a more significant contribution to the theory of singular perturbations. The computations arising in this application have been given in [14].

We consider the problem of approximating asymptotically the function $U(x,y;\epsilon)$ satisfying the differential equation

$$(5.50) \quad L_\epsilon U \equiv \epsilon \left[\frac{\partial^2 U}{\partial x^2} + \frac{\partial^2 U}{\partial y^2} \right] - \frac{\partial U}{\partial y} = 0, \quad x \geq 0, y \geq 0, 0 < \epsilon \ll 1,$$

and the boundary conditions

$$(5.51a) \quad U(x,0) = kx$$

$$(5.51b) \quad U(0,y) = \Phi(y), \quad \Phi(0) = 0.$$

Our purpose is to expand the exact solution of (5.50), (5.51) in order to understand the mechanism of its boundary layers.

In section 5.7 an approach from singular perturbation point of view will be given. Here we study the exact solution, as obtained by means of Green's theorem

$$U(x,y;\varepsilon) = \frac{-1}{\pi} \int_0^\infty \Phi_2(p) \exp\left(\frac{y-p}{2\varepsilon}\right) \frac{\partial}{\partial x} \left[K_0\left(\frac{\sqrt{x^2+(p-y)^2}}{2\varepsilon}\right) - K_0\left(\frac{\sqrt{x^2+(p+y)^2}}{2\varepsilon}\right) \right] dp + kx,$$

where $K_0(z)$ denotes a modified Bessel function.

Introduction of a transformation of type

$$(5.52) \quad x = \xi\varepsilon^\alpha, \quad y = \eta\varepsilon^\beta, \quad \alpha, \beta \geq 0$$

yields for

$$a. \quad \alpha = \beta = 0,$$

$$(5.53a) \quad \psi_{01}(\xi, \eta) = k\xi,$$

$$b. \quad 0 < \alpha < 1/2, \quad \beta = 0,$$

$$(5.53b) \quad \psi_{0,v_{11}}(\xi, \eta) = k\xi,$$

$$c. \quad 0 < \alpha = \beta < 1$$

$$(5.53c) \quad \psi_{0,v_{12}}(\xi, \eta) = k\xi,$$

$$d. \quad \alpha = 1/2, \quad \beta = 0,$$

$$(5.53d) \quad \psi_{11}(\xi, \eta) = \sqrt{\frac{2}{\pi}} \int_{\xi/\sqrt{2}\eta}^\infty e^{-\frac{1}{2}t^2} \Phi\left(\eta - \frac{\xi^2}{2t^2}\right) dt,$$

$$e. \quad 1/2 < \alpha < 1, \quad \beta = 2\alpha - 1,$$

$$(5.53e) \quad \psi_{1,\mu_1}(\xi, \eta) = \Phi'(0) \sqrt{\frac{2}{\pi}} \int_{\xi/\sqrt{2\eta}}^{\infty} e^{-\frac{1}{2}t^2} \left(\eta - \frac{\xi^2}{2t^2} \right) dt,$$

$$f. \quad \alpha = 1, \beta = 1,$$

$$(5.53f) \quad \psi_{12}(\xi, \eta) = -\frac{\Phi'(0)}{\pi} \int_0^{\infty} p \exp\left(\frac{\eta-p}{2}\right) \frac{\partial}{\partial \xi} \left[K_0\left(\frac{\sqrt{\xi^2+(p-\eta)^2}}{2}\right) - K_0\left(\frac{\sqrt{\xi^2+(p+\eta)^2}}{2}\right) \right] dp + k\xi,$$

$$g. \quad \beta < \alpha < 1/2(\beta+1), \quad 0 < \alpha < 1$$

$$(5.53g) \quad \psi_{0,\alpha_{11}}(\xi, \eta) = k\xi.$$

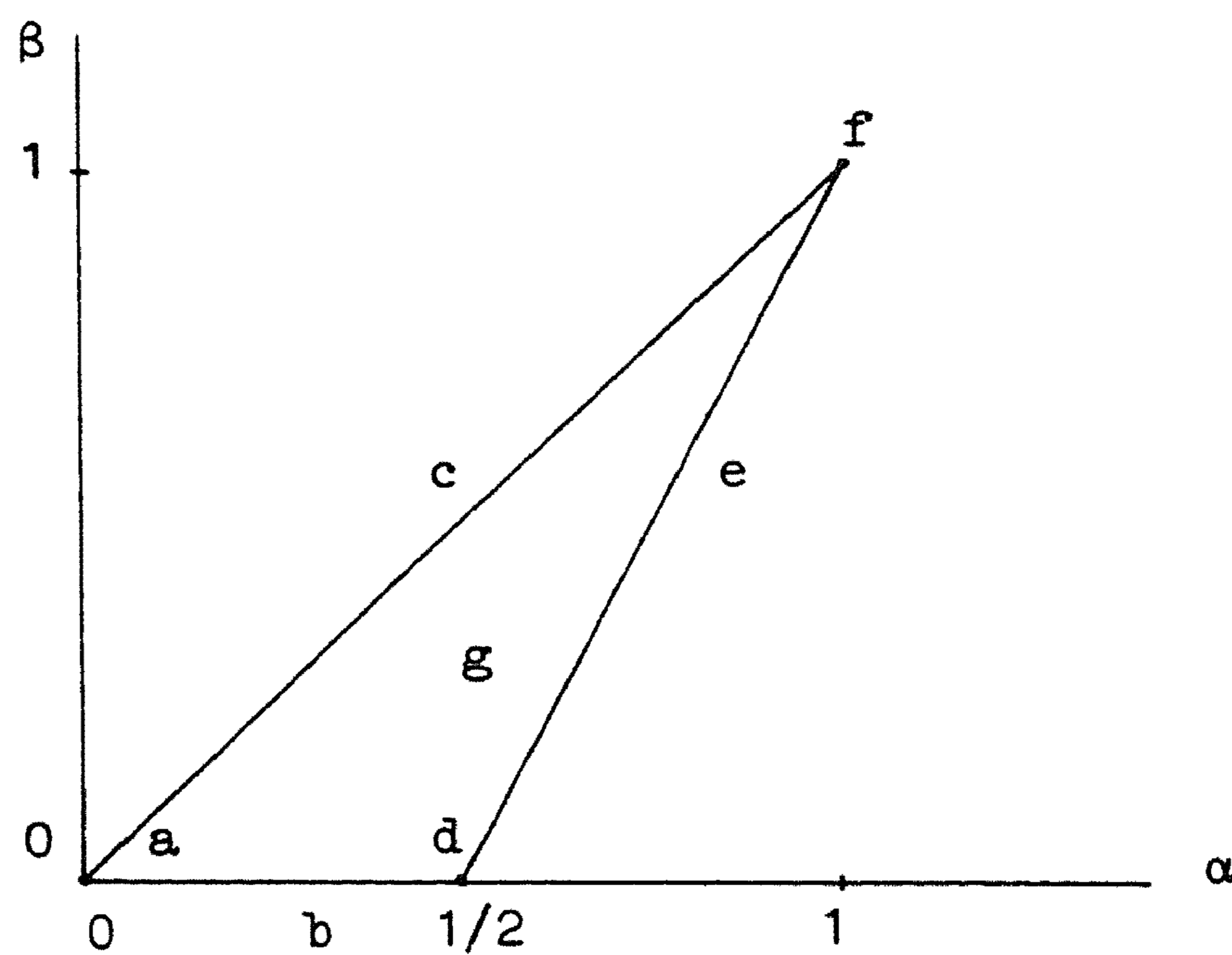

fig. 5.9

The approximation, which holds uniformly for $x \geq 0, y \geq 0$, is

$$(5.54) \quad \phi_0(x, y; \epsilon) = \psi_{01}(x, y) + \psi_{11}(x/\sqrt{\epsilon}, y) + \psi_{12}(x/\epsilon, y/\epsilon)\epsilon + \\ - \psi_{0,\nu_{11}}(x, y) - \psi_{0,\nu_{12}}(x, y) - \psi_{1,\mu_1}(x/\sqrt{\epsilon}, y) +$$

$$+ \psi_{0,\alpha_{11}}(x,y).$$

5.7 THE BIRTH OF THE PARABOLIC BOUNDARY-LAYER

In the singular perturbation solution of (5.50), (5.51) the degenerations of the differential operator L_ϵ are considered for transformations of type

$$(5.55) \quad x = \xi\epsilon^\alpha, \quad y = \eta\epsilon^\beta, \quad \alpha, \beta \geq 0.$$

In figure 5.10 all degenerations of L_ϵ are shown:

$$\lim_{\epsilon \rightarrow 0} \overline{\delta}_{\alpha,\beta}^*(\epsilon)L_\epsilon = L_{\alpha,\beta}^{(0)}.$$

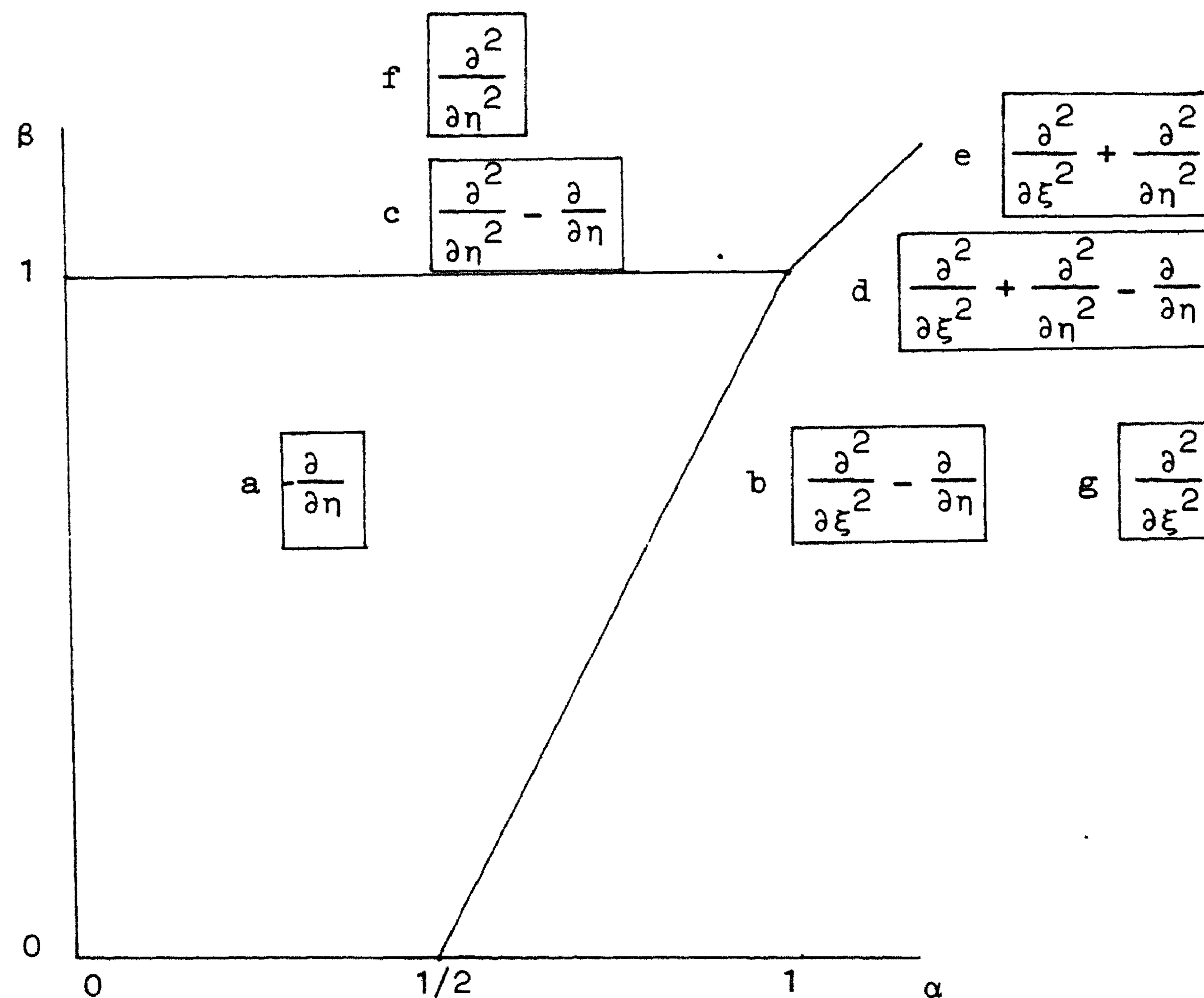

fig. 5.10

Further, formal limit functions, satisfying

$$(5.56) \quad L_{\alpha, \beta}^{(0)} \bar{\psi}_{\alpha, \beta}(\xi, \eta) = 0,$$

are introduced.

In chapter 4 the usual singular perturbation method was demonstrated, before the term "formal limit function" was used. However, for the present problem such a solution is not available in literature.

In a first approach the general solutions of the local equations are determined.

- a. $\bar{\psi}_{\alpha_a, \beta_a} = P_{\alpha_a, \beta_a}(\xi), \quad 0 \leq \alpha_a < 1/2(\beta_a - 1), \quad 0 \leq \beta_a < 1,$
- b. $V_{\alpha_b, \beta_b} = F_{\alpha_b, \beta_b}(p, q) \exp\left[\frac{-(\xi-p)^2}{4(\eta-p)}\right] / \sqrt{4\pi(\eta-q)},$
 $\alpha_b = 1/2(\beta_b - 1), \quad 0 \leq \beta_b < 1,$
- c. $\bar{\psi}_{\alpha_c, 1} = Q_{\alpha_c, 1}(\xi)e^\eta + R_{\alpha_c, 1}(\xi)\eta + P_{\alpha_c, 1}(\xi), \quad 0 \leq \alpha_c < 1,$
- d. $V_{1, 1} = F_{1, 1}(p, q) \exp\left[\frac{y-q}{2\epsilon}\right] K_0\left(\frac{\sqrt{(\xi-p)^2 + (\eta-q)^2}}{2\epsilon}\right),$
- e. $V_{\alpha_e, \beta_e} = F_{\alpha_e, \beta_e}(p, q) \ln\left(\frac{\sqrt{(\xi-p)^2 + (\eta-q)^2}}{2\epsilon}\right), \quad 1 < \alpha_e = \beta_e,$
- f. $\bar{\psi}_{\alpha_f, \beta_f} = R_{\alpha_f, \beta_f}(\xi)\eta + P_{\alpha_f, \beta_f}(\xi), \quad 0 \leq \alpha_f < \beta_f, \quad 1 < \beta_f,$
- g. $\bar{\psi}_{\alpha_g, \beta_g} = S_{\alpha_g, \beta_g}(\eta)\xi + T_{\alpha_g, \beta_g}(\eta), \quad 1/2(\beta_g - 1) < \alpha_g, \quad 0 \leq \beta_g \leq 1,$
and $\beta_g < \alpha_g, \quad 1 < \beta_g.$

The functions $V_{\alpha,\beta}$ are Green's functions, which are used to determine solutions that satisfy the boundary conditions.

Because of the matching conditions the following relations hold

$$Q_{\alpha_c,1}(\xi) \equiv R_{\alpha_c,1}(\xi) \equiv R_{\alpha_f,\beta_f}(\xi) \equiv 0,$$

$$P_{\alpha,\beta_a}(\xi) \equiv P_{\alpha,1}(\xi) \equiv P_{\alpha,\beta_f}(\xi) \equiv P_{\alpha}(\xi).$$

Moreover, $\bar{\psi}_{\alpha_e,\beta_e}$ is contained in $\bar{\psi}_{1,1}$ and $\bar{\psi}_{\alpha_g,\beta_g}$ in $\bar{\psi}_{1,1}$.

Taking account of the boundary conditions we obtain expressions for the formal limit functions which are identical to (5.53).

Finally it is proved that

$$(5.57) \quad \phi(x,y;\varepsilon) = \phi_0(x,y;\varepsilon) + Z(x,y;\varepsilon),$$

where $Z(x,y;\varepsilon) = o(\varepsilon)$ for $x \geq 0$, $y \geq 0$ and $\phi_0(x,y;\varepsilon)$ is given in (5.54). Substitution of (5.57) in (5.50) yields

$$(5.58) \quad L_{\varepsilon} Z = -\varepsilon \left[\frac{\partial^2}{\partial x^2} \psi_{01}(x,y) + \frac{\partial^2}{\partial y^2} \psi_{11}(x/\sqrt{\varepsilon},y) - \frac{\partial^2}{\partial y^2} \psi_{1,\mu_1}(x/\sqrt{\varepsilon},y) \right].$$

The singular terms in the right-hand side of (5.56) cancel out, so

$$(5.59) \quad L_{\varepsilon} Z = o(\varepsilon)$$

for $x \geq 0$, $y \geq 0$.

Moreover, from (5.51) and (5.54) it follows that

$$(5.60) \quad Z(x,0) = Z(0,y) = 0.$$

In a theorem Eckhaus and De Jager [7] pose that under conditions (5.59),

$$(5.60) \quad Z(x,y) = o(\varepsilon) \text{ uniformly for } x \geq 0, y \geq 0.$$

Since in formula (5.54)

$$\varepsilon\psi_{12}(x/\varepsilon, y/\varepsilon) - \psi_{1,\mu_1}(x/\sqrt{\varepsilon}, y) = o(\varepsilon)$$

uniformly, the approximation can be simplified:

$$\phi(x, y; \varepsilon) = \psi_{01}(x, y) + \psi_{11}(x/\varepsilon, y) - \psi_{0,\nu_{11}}(x, y) + o(\varepsilon)$$

uniformly for $x \geq 0, y \geq 0$.

Remark For an approximation with a higher degree of accuracy the reader is referred to [14].

CHAPTER VI THE BIRTH OF A BOUNDARY LAYER IN A LINEAR ELLIPTIC SINGULAR
PERTURBATION PROBLEM

6.1 PRELIMINARY REMARKS

In this chapter the elliptic problem formulated in section 4.4 will be submitted to a more detailed analysis. By means of the two-dimensional coordinate stretching technique the boundary layer structure near the singular points A and B (see figure 4.1) is revealed. Moreover, higher order approximations of the solution are constructed. Until so far we only employed limit functions as local approximations of the solution. We now introduce asymptotic series as local approximations.

Definition 6.1 The function $\phi_t^{(m_t)}(\xi_t, \eta_t; \epsilon)$ is an approximation up to $\delta_{m_t}(\epsilon)$ of $\phi(x, y; \epsilon)$, if for

$$(6.1) \quad x = \xi_t \delta_{x,t}(\epsilon), \quad y = \eta_t \delta_{y,t}(\epsilon), \quad \delta_{x,t} \lesssim 1, \quad \delta_{y,t} \lesssim 1$$

$$(6.1a) \quad \phi_t^{(m_t)}(\xi_t, \eta_t; \epsilon) = T_0(\xi_t, \eta_t) \delta_t^{(0)}(\epsilon) + T_1(\xi_t, \eta_t) \delta_t^{(1)}(\epsilon) + \dots + T_{m_t}(\xi_t, \eta_t) \delta_t^{(m_t)}(\epsilon),$$

where the term $T_0(\xi_t, \eta_t)$ satisfies

$$(6.2a) \quad \lim_{\xi_t, \eta_t} \left[\frac{\phi(x, y; \epsilon)}{\delta_t^{(0)}(\epsilon)} - T_0(\xi_t, \eta_t) \right] = 0$$

and the terms $T_n(\xi_t, \eta_t)$ satisfy

$$(6.2b) \quad \lim_{\xi_t, \eta_t} \left[\frac{\phi(x, y; \epsilon) - \sum_{k=0}^{n-1} T_k(\xi_t, \eta_t) \delta_t^{(k)}(\epsilon)}{\delta_t^{(n)}(\epsilon)} - T_n(\xi_t, \eta_t) \right] = 0,$$

$n = 1, 2, \dots, m_t.$

If $\delta_{x,t} \ll 1$ or $\delta_{y,t} \ll 1$ this approximation is called a "local" approximation.

Definition 6.2 A local approximation $\Phi_u^{(m_u)}(\xi_u, \eta_u; \varepsilon)$ is contained in $\Phi_v^{(m_v)}(\xi_v, \eta_v; \varepsilon)$, if

$$\lim_{\xi_u, \eta_u} \left[\Phi_v^{(m_v)} \left(\xi_u \frac{\delta_{x,u}}{\delta_{x,v}}, \eta_u \frac{\delta_{y,u}}{\delta_{y,v}} \right) \frac{1}{\delta_u^{(0)}(\varepsilon)} \right] = U_0(\xi_u, \eta_u),$$

$$\lim_{\xi_u, \eta_u} \left[\left\{ \Phi_v^{(m_v)} \left(\xi_u \frac{\delta_{x,u}}{\delta_{x,v}}, \eta_u \frac{\delta_{y,u}}{\delta_{y,v}} \right) - \sum_{k=1}^{n-1} U_k(\xi_u, \eta_u) \delta_u^{(k)}(\varepsilon) \right\} \frac{1}{\delta_u^{(n)}(\varepsilon)} \right] =$$

$$U_n(\xi_u, \eta_u), \quad n = 1, 2, \dots, m_u.$$

Definition 6.3 An approximation $\Phi_v^{(m_v)}$ is called significant, if $\Phi_v^{(0)}(\xi_v, \eta_v)$ is not contained in any other local approximation.

We consider the function $\Phi(x, y; \varepsilon)$ satisfying a differential equation of the elliptic type, i.e.

$$(6.3) \quad L_\varepsilon \Phi \equiv \varepsilon L_2 \Phi + L_1 \Phi = h(x, y)$$

in G , where L_1 and L_2 denote the differential operators

$$L_2 \equiv a(x, y) \frac{\partial^2}{\partial x^2} + 2b(x, y) \frac{\partial^2}{\partial x \partial y} + c(x, y) \frac{\partial^2}{\partial y^2} + d(x, y) \frac{\partial}{\partial x} + e(x, y) \frac{\partial}{\partial y} + f(x, y),$$

and

$$L_1 \equiv - \frac{\partial}{\partial x} - g(x, y).$$

We assume that the operator L_2 is elliptic, $a(x, y) > 0$ and $g(x, y) - \varepsilon f(x, y) > 0$ in \bar{G} , and that the coefficients $a(x, y), \dots, h(x, y)$ are continuously differentiable up to order $2m + 3$ ($m=0, 1, 2, \dots$) in \bar{G} . Moreover, it is assumed that G is a bounded strictly convex domain with a smooth boundary Γ which has the property that its parametric representation

with the arc length as parameter is continuously differentiable up to $2m + 6$. At the boundary $\phi(x,y;\epsilon)$ satisfies the condition

$$(6.4) \quad \phi \Big|_{\Gamma} = \psi(x,y),$$

where $\psi(x,y)$ is continuously differentiable up to order $2m + 3$ for all points at Γ . Without loss of generality it may be assumed that the position of the domain G with regard to the x,y -coordinate system is as follows: Let A and B be the points of the boundary Γ , where the characteristics of L_1 (the lines $y=\text{constant}$) are tangent to Γ . We assume that A is on the positive y -axis see figure 6.1. In this chapter we deal with the case of first order tangency in both A and B . In section 6.4 the case of higher order tangency is studied.

The part of the boundary Γ at the left-hand side of A and B is called Γ_l and the part at the right-hand side Γ_r .

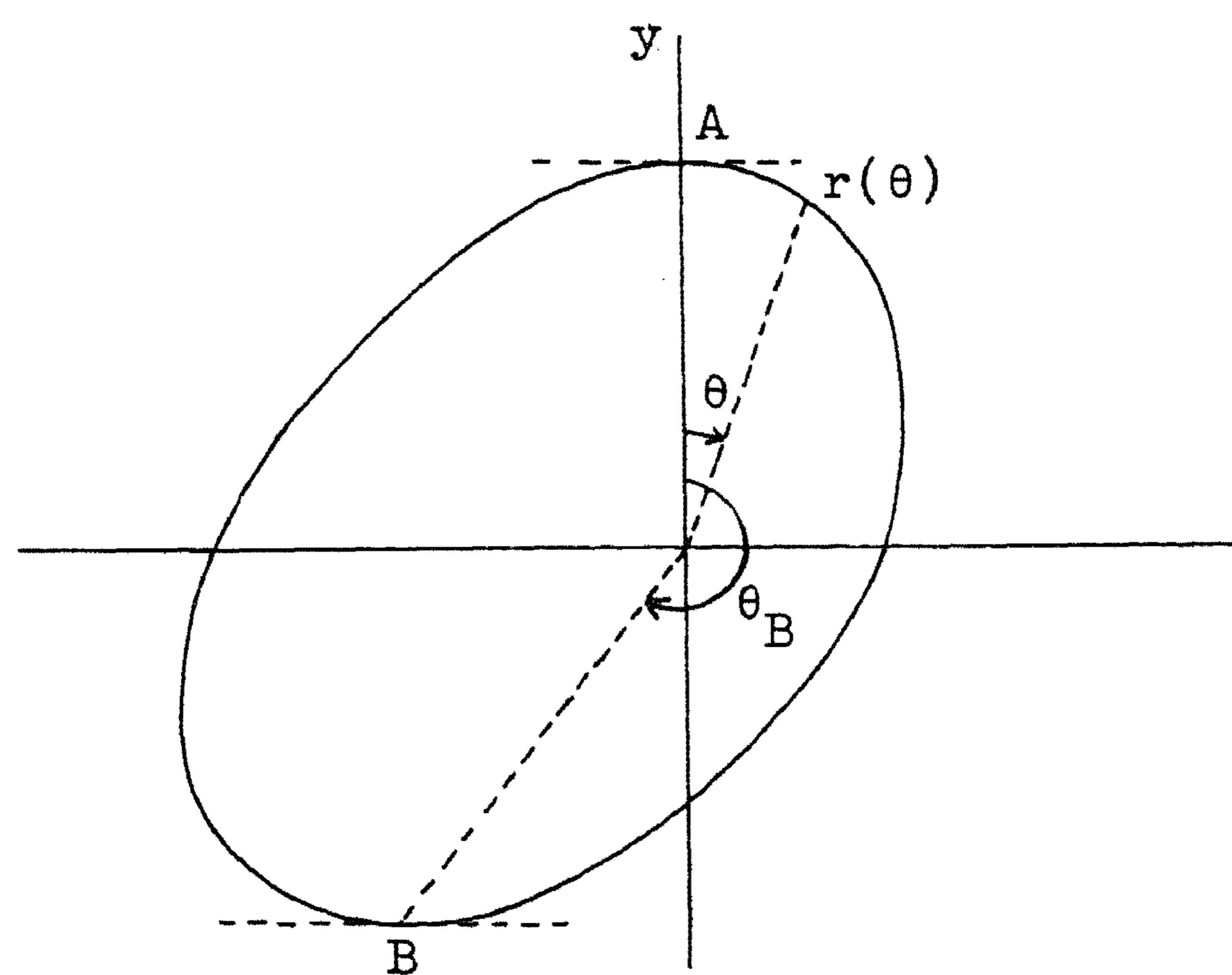

fig. 6.1

In order to apply the method developed in the preceding chapter we introduce the ρ, θ -coordinate system

$$(6.5) \quad x = (r(\theta) - \rho) \sin \theta, \quad y = (r(\theta) - \rho) \cos \theta,$$

where $0 \leq \rho \leq r(\theta)$ and $0 \leq \theta \leq \theta_B$.

Substitution of (6.5) in (6.3) yields the differential equation

$$(6.6) \quad L_\epsilon \phi \equiv \epsilon S_2 \phi + S_1 \phi = h(\rho, \theta),$$

$$S_2 \equiv \frac{p}{(r(\theta)-\rho)^2} \frac{\partial^2}{\partial \theta^2} + \left\{ \frac{2r'(\theta)p}{(r(\theta)-\rho)^2} - \frac{q}{r(\theta)-\rho} \right\} \frac{\partial^2}{\partial \theta \partial \rho} +$$

$$+ \left\{ \frac{r'(\theta)p}{(r(\theta)-\rho)^2} - \frac{r'(\theta)q}{r(\theta)-\rho} + t \right\} \frac{\partial^2}{\partial \rho^2} + \left\{ \frac{-q}{(r(\theta)-\rho)^2} + \frac{d \cos \theta - e \sin \theta}{r(\theta)-\rho} \right\} \frac{\partial}{\partial \theta} +$$

$$+ \left\{ \frac{r''(\theta)p - r'(\theta)q}{(r(\theta)-\rho)^2} - \frac{p + r(\theta)(d \cos \theta - e \sin \theta)}{r(\theta)-\rho} + (d \sin \theta + e \cos \theta) \right\} \frac{\partial}{\partial \rho} + f,$$

$$S_1 \equiv - \left[\frac{\cos \theta}{r(\theta)-\rho} \frac{\partial}{\partial \theta} + \left\{ \frac{r'(\theta) \cos \theta}{r(\theta)-\rho} - \sin \theta \right\} \frac{\partial}{\partial \rho} + g \right],$$

$$p = a \cos^2 \theta - 2b \sin \theta \cos \theta + c \sin^2 \theta,$$

$$q = (a-c) \sin 2\theta + 2b \cos 2\theta,$$

$$t = a \sin^2 \theta + 2b \sin \theta \cos \theta + c \cos^2 \theta.$$

Here the coefficients a, \dots, h are functions of ρ and θ .

Substitution of

$$(6.7) \quad \rho = \xi \epsilon^\nu, \quad \theta = \eta \epsilon^\mu, \quad \nu > 0, \mu \geq 0,$$

into the operator L_ϵ leads to the operator expansion

$$(6.8) \quad \epsilon^\gamma L_\epsilon \equiv N_0 + \epsilon^\gamma N_1 + \epsilon^{2\gamma} N_2 + \dots + \epsilon^{m\gamma} N_m.$$

the terms of the formal local approximation

$$(6.9) \quad \overline{\phi}_t^{(m)}(\xi, \eta; \varepsilon) = \\ T_0(\xi, \eta) + \varepsilon^\gamma T_1(\xi, \eta) + \varepsilon^{2\gamma} T_2(\xi, \eta) + \dots + \varepsilon^{m\gamma} T_m(\xi, \eta)$$

are determined by an iteration process, which follows from an equalization of coefficients of terms with equal powers in ε in the equation

$$(N_0 + \varepsilon^\gamma N_1 + \varepsilon^{2\gamma} N_2 + \dots + \varepsilon^{m\gamma} N_m) (T_0 + \varepsilon^\gamma T_1 + \varepsilon^{2\gamma} T_2 + \dots + \varepsilon^{m\gamma} T_m) = \varepsilon^\gamma h.$$

Moreover, the terms of a formal local approximation are required to satisfy a matching condition. Contrary to the limit functions no matching theorem exists for the local approximations. This problem is still unsolved.

For the formal local approximation we propose the following type of matching condition.

Assuming that there exist two significant formal local approximations

$$\phi(x, y; \varepsilon) = \overline{\phi}_u^{(m)}(\xi_u, \eta_u; \varepsilon) + Z_{m_u}(\xi_u, \eta_u; \varepsilon), \\ \overline{\phi}_u^{(m)} = U_0 \delta_{u,0} + U_1 \delta_{u,1} + U_2 \delta_{u,2} + \dots + U_{m_u} \delta_{u,m_u},$$

and

$$\phi(x, y; \varepsilon) = \overline{\phi}_v^{(m)}(\xi_v, \eta_v; \varepsilon) + Z_{m_v}(\xi_v, \eta_v; \varepsilon), \\ \overline{\phi}_v^{(m)} = V_0 \delta_{v,0} + V_1 \delta_{v,1} + V_2 \delta_{v,2} + \dots + V_{m_v} \delta_{v,m_v},$$

of which the corresponding limits have a common domain of convergence, we take a path $x = \xi_w \delta_{x,w}$, $y = \xi_w \delta_{y,w}$ in this domain. Substitution of $\xi_u = \xi_w \delta_{x,w} / \delta_{x,u}$, $\eta_u = \eta_w \delta_{y,w} / \delta_{y,u}$ and $\xi_v = \xi_w \delta_{y,w} / \delta_{y,v}$, $\eta_v = \eta_w \delta_{y,w} / \delta_{y,v}$ into the series and development of its coefficients yields

$$\begin{aligned}
\phi = & U_0^{(0)} \delta_{u,0}^{(0)} + U_0^{(1)} \delta_{u,0}^{(1)} + \dots + \\
& \dots \dots \dots + \dots + \\
& U_{m_u}^{(0)} \delta_{u,m_u}^{(0)} + U_{m_u}^{(1)} \delta_{u,m_u}^{(1)} + \dots + \\
& Z_{m_u}^{(0)} \delta_{z,m_u}^{(0)} + Z_{m_u}^{(1)} \delta_{u,m_u}^{(1)} + \dots ,
\end{aligned}$$

and

$$\begin{aligned}
\phi = & V_0^{(0)} \delta_{v,0}^{(0)} + V_0^{(1)} \delta_{v,0}^{(1)} + \dots + \\
& \dots \dots \dots + \dots + \\
& V_{m_v}^{(0)} \delta_{v,m_v}^{(0)} + V_{m_v}^{(1)} \delta_{v,m_v}^{(1)} + \dots + \\
& Z_{m_v}^{(0)} \delta_{z,m_v}^{(0)} + Z_{m_v}^{(1)} \delta_{v,m_v}^{(1)} + \dots .
\end{aligned}$$

Equalization of the coefficients of equal order functions of both series leads to the matching condition. When such a coefficient contains a term of Z_{m_u} or Z_{m_v} , of course, no matching information is produced by such an equalization. In section 6.2 we will see how this matching condition works out for this very problem. Besides the boundary conditions of section 4.4d other boundary conditions arise, which we will also meet in section 6.2. The reader will certainly have observed the links with the preceding theory. The first term of a local approximation represents the limit function, and the first term of a formal local approximation is identical to the formal limit functions.

Our objective is to construct the significant formal approximations of $\phi(x,y;\varepsilon)$ (see section 6.2). In figure 6.2 we show some degenerations of L_ε for a transformation of type (6.7) as far as is important for the present problem.

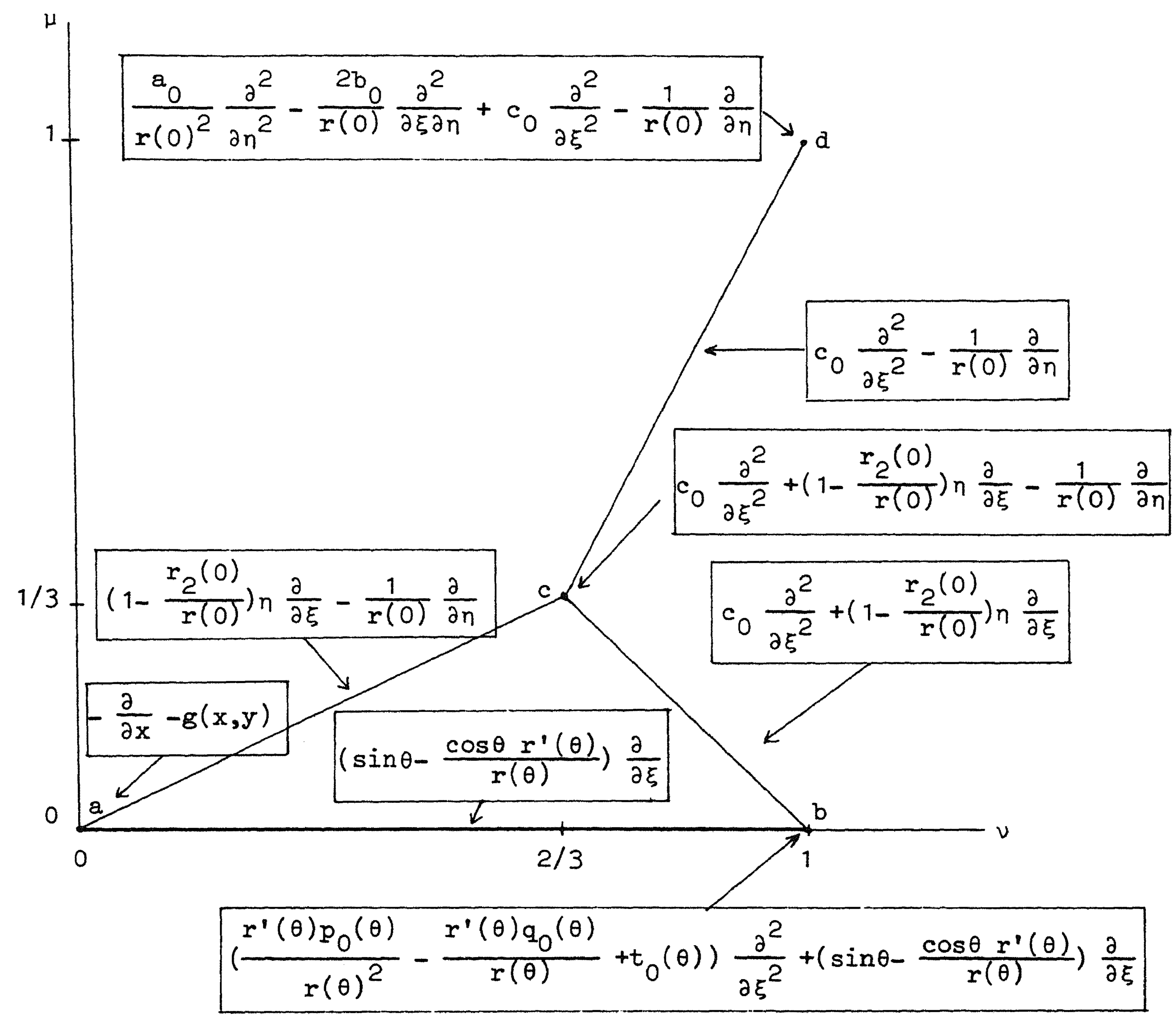

fig. 6.2

In terms of limit functions we expect a structure as shown in figure 6.3.

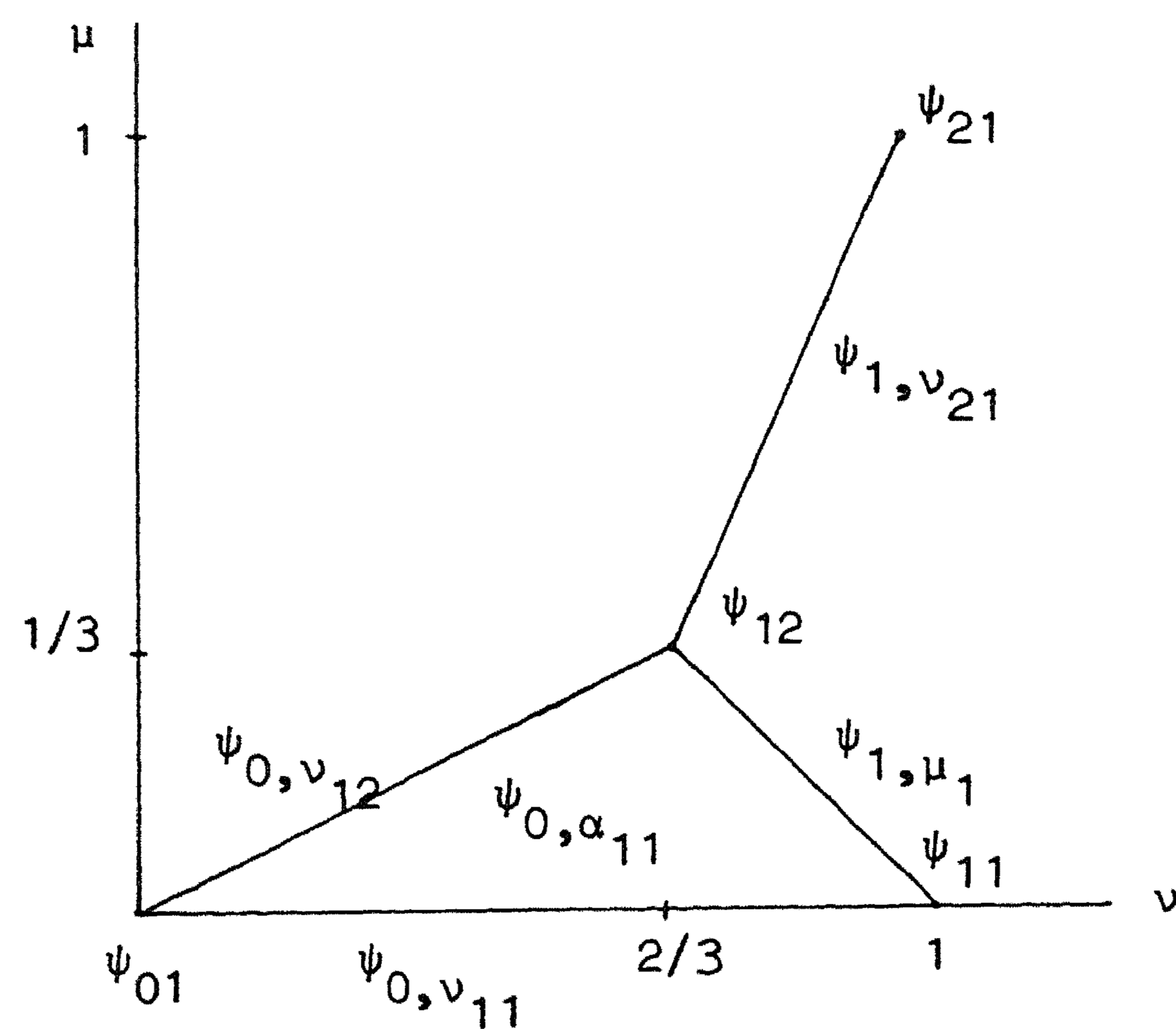

fig. 6.3

The significant formal approximations are:

- a. $v = 0, \mu = 0,$ the outer expansion,
- b. $v = 1, \mu = 0,$ the ordinary boundary layer expansion,
- c. $v = 2/3, \mu = 1/3,$ the intermediate boundary layer expansion,
- d. $v = 1, \mu = 1,$ the interior boundary layer expansion.

In section 6.3 these expansions are composed to a formal uniformly valid approximation. With the maximum principle it is proved that such a formal approximation is uniformly valid with a certain degree of accuracy.

6.2 LOCALLY VALID EXPANSIONS

a. Outer expansion

It is supposed that there exists an expansion

$$(6.10) \quad \bar{\phi}_u^{(m)} = \sum_{n=0}^m U_n(x,y) \varepsilon^n,$$

of which the coefficients U_n satisfy the differential equations

$$L_1 U_0 = h(x,y), \quad L_1 U_n = L_2 U_{n-1}, \quad n = 1, 2, \dots, m.$$

Along Γ_1 the boundary conditions are

$$U_0 \Big|_{\Gamma_1} = \psi(x,y) \quad \text{and} \quad U_n \Big|_{\Gamma_1} = 0, \quad n = 1, 2, 3, \dots, m.$$

This iterative system is solved in an elementary way. It is easily verified that the functions

$$(6.11a) \quad U_0(x,y) = \psi[k_{1y}^{-1}(y)] - \int_{k_{1x}(k_{1y}^{-1}(y))}^x \exp\left[-\int_p^x g(\bar{p},y) d\bar{p}\right] \{h(p,y) + g(p,y) \psi[k_{1y}^{-1}(y)]\} dp,$$

$$(6.11b) \quad U_n(x,y) = \int_{k_{1x}(k_{1y}^{-1}(y))}^x \exp\left[-\int_p^x g(\bar{p},y) d\bar{p}\right] \{L_2 U_{n-1}(p,y)\} dp,$$

$$n = 1, 2, \dots, m,$$

satisfy both the equations and the boundary conditions. In (6.11) the following functions were introduced:

$$x = r(\theta) \sin\theta = k_{1x}(\theta), \quad y = r(\theta) \cos\theta = k_{1y}(\theta)$$

$$\text{for } \theta_B \leq \theta \leq 2\pi,$$

and

$$\psi[\theta] = \psi(k_{1x}(\theta), k_{1y}(\theta)).$$

b. Ordinary boundary layer expansion

Substitution of (6.7) with $\nu = 1$, $\mu = 0$ in the coefficients a, \dots, h yields the expansions

$$(6.12a) \quad a(\varepsilon\xi, \theta) = a_0(\theta) + \varepsilon\xi a_1(\theta) + \dots + \varepsilon^{m+1} \xi^{m+1} a_{m+1}(\bar{\theta}),$$

. + ... + ,

$$(6.12h) \quad h(\varepsilon\xi, \theta) = h_0(\theta) + \varepsilon\xi h_1(\theta) + \dots + \varepsilon^{m+1} \xi^{m+1} h_{m+1}(\bar{\theta}).$$

Using these expansions we obtain for the operator L_ε

$$\varepsilon L_\varepsilon \equiv M_0 + \varepsilon M_1 + \varepsilon^2 M_2 + \dots + \varepsilon^{m+1} M_{m+1},$$

$$M_0 \equiv \left\{ \frac{r'(\theta)p_0(\theta)}{r(\theta)^2} - \frac{r'(\theta)q_0(\theta)}{r(\theta)} + t_0(\theta) \right\} \frac{\partial^2}{\partial \xi^2} + \left\{ \sin\theta - \frac{\cos\theta r'(\theta)}{r(\theta)} \right\} \frac{\partial}{\partial \xi}.$$

An ordinary boundary layer expansion

$$(6.13) \quad \bar{\phi}_v^{(m)} = \sum_{n=0}^m V_n(\xi, \theta) \varepsilon^n,$$

is introduced such that $V_n(\xi, \theta)$ satisfy the equations

$$(6.14) \quad M_0 V_0 = 0, \quad M_0 V_n = - \sum_{i=1}^n M_i V_{n-i}, \quad n = 1, 2, \dots, m.$$

Moreover, the functions V_n satisfy at Γ_r the boundary conditions

$$(6.15) \quad V_0(0, \theta) = \psi[\theta], \quad V_n(0, \theta) = 0, \quad n = 1, 2, \dots, m,$$

where $\psi[\theta] = \psi(k_{2x}(\theta), k_{2y}(\theta))$,

$$x = r(\theta) \sin\theta = k_{2x}(\theta), \quad y = r(\theta) \cos\theta = k_{2y}(\theta), \quad 0 \leq \theta \leq \theta_B.$$

The solution can be written as

$$(6.16) \quad V_n(\xi, \theta) = A_n(\xi, \theta)e^{-\xi k(\theta)} + B_n(\xi, \theta), \quad n = 0, 1, 2, \dots, m,$$

$$k(\theta) = \left\{ \sin\theta - \frac{\cos\theta r'(\theta)}{r(\theta)} \right\} / \left\{ \frac{r'(\theta)p_0(\theta)}{r(\theta)} - \frac{r'(\theta)q_0(\theta)}{r(\theta)} + t_0(\theta) \right\},$$

where $A_n(\xi, \theta)$ and $B_n(\xi, \theta)$ denote polynomials in ξ . Conditions (6.15) change into

$$A_0(0, \theta) + B_0(0, \theta) = \psi[\theta], \quad A_n(0, \theta) + B_n(0, \theta) = 0, \\ n = 1, 2, \dots, m.$$

When in the outer expansion (6.10) the local coordinates corresponding to $\nu = 1$, $\mu = 0$ are substituted and the expansion is reordered, it transforms into

$$\bar{\phi}_u^{(m)} = U^{(0)}(\xi, \theta) + \varepsilon U^{(1)}(\xi, \theta) + \varepsilon^2 U^{(2)}(\xi, \theta) + \dots,$$

where

$$U^{(0)} = U_0|_{\Gamma_r}, \quad U^{(1)} = U_1|_{\Gamma_r} + \xi \frac{\partial U_0}{\partial \rho}|_{\Gamma_r}, \dots$$

The matching condition takes the form

$$\lim_{\xi \rightarrow \infty} [V_n(\xi, \theta) - U^{(n)}(\xi, \theta)] = 0, \quad n = 0, 1, 2, \dots, m.$$

Thus, it turns out that

$$A_0(\xi, \theta) = \psi[\theta] - U_0(k_{2x}(\theta), k_{2y}(\theta)),$$

$$B_0(\xi, \theta) = U_0(k_{2x}(\theta), k_{2y}(\theta)).$$

c. Intermediate boundary layer expansion

We consider the case $\nu = 2/3$, $\mu = 1/3$. Again the coefficients a, \dots, h are expanded in Taylor series.

$$(6.17a) \quad a(\varepsilon^{2/3}\xi, \varepsilon^{1/3}\eta) = a_0 + \varepsilon^{1/3}a_1(\eta) + \varepsilon^{2/3}a_2(\xi, \eta) + \dots + \varepsilon^{m+1/3}a_{3m+1}(\bar{\xi}, \bar{\eta}),$$

.

$$(6.17h) \quad h(\varepsilon^{2/3}\xi, \varepsilon^{1/3}\eta) = h_0 + \varepsilon^{1/3}h_1(\eta) + \varepsilon^{2/3}h_2(\xi, \eta) + \dots + \varepsilon^{m+1/3}h_{3m+1}(\bar{\xi}, \bar{\eta}).$$

L_ε is expanded as follows

$$\varepsilon^{1/3}L_\varepsilon \equiv T_0 + \varepsilon^{1/3}T_1 + \varepsilon^{2/3}T_2 + \dots + \varepsilon^{m+1/3}T_{3m+1},$$

$$T_0 \equiv c_0 \frac{\partial^2}{\partial \xi^2} + \left(1 - \frac{r_2(0)}{r(0)}\right) \eta \frac{\partial}{\partial \xi} - \frac{1}{r(0)} \frac{\partial}{\partial \eta}.$$

Supposing the existence of an intermediate boundary layer expansion

$$(6.18) \quad \bar{\phi}_y^{(m)} = \sum_{n=0}^{3m} Y_n(\xi, \eta) \varepsilon^{n/3},$$

we obtain the equations

$$(6.19) \quad T_0 Y_0 = 0, \quad T_0 Y_n = - \sum_{i=1}^n T_i Y_{n-i} + h_{n-1}(\xi, \eta), \quad n = 1, 2, \dots, 3m.$$

In addition the functions $Y_n(\xi, \eta)$ have to satisfy conditions such that they are uniquely determined. On the one hand the intermediate boundary layer expansion has to match the outer and the ordinary boundary layer expansion, on the other hand it has to satisfy the boundary condition $\psi(\varepsilon^{1/3}\eta)$ for $\xi = 0$ and $\eta \neq 0$.

In the outer expansion (6.10) the local coordinates corresponding to $\nu = 2/3$, $\mu = 1/3$ are substituted and the expansion is reordered. This yields

$$(6.20) \quad \bar{\phi}_u^{(m)} = U^{(0)}(\xi, \eta) + \varepsilon^{1/3}U^{(1/3)}(\xi, \eta) + \varepsilon^{2/3}U^{(2/3)}(\xi, \eta) + \dots$$

The outer expansion matches the intermediate boundary layer expansion, provided that for $\xi/\eta^2 = o(1)$ and $|\eta| \gg 1$,

$$(6.21) \quad Y_n(\xi, \eta) = U^{(n/3)}(\xi, \eta).$$

For this case the limit $\xi = c\eta^2$, $\eta \rightarrow \infty$ corresponds to the direction of the line, which connects a and c, see figures 6.2, 6.3 and 6.4. The terms $U^{(n/3)}(\xi, \eta)$ consist of contributions of all terms U_0, U_1, \dots, U_m of (6.10)

$$U^{(n/3)}(\xi, \eta) = U_0^{(n/3)}(\xi, \eta) + U_1^{(n/3)}(\xi, \eta) + \dots + U_m^{(n/3)}(\xi, \eta).$$

According to the matching principle for $Y_n(\xi, \eta)$ a same expansion must hold

$$Y_n(\xi, \eta) = Y_n^{(0)}(\xi, \eta) + Y_n^{(1)}(\xi, \eta) + Y_n^{(2)}(\xi, \eta) + \dots + Y_n^{(m)}(\xi, \eta),$$

$$(\xi/\eta^2 = 0(1), |\eta| \gg 1)$$

where

$$(6.22) \quad Y_n^{(k)}(\xi, \eta) = U_k^{(n/3)}(\xi, \eta) = O(\eta^{n-3k}), \quad k = 0, 1, 2, \dots, m,$$

$$n = 0, 1, 2, \dots, 3m.$$

A same procedure is applied to obtain a matching formula for the ordinary boundary layer expansion (6.13) and the intermediate boundary layer expansion. The local coordinates corresponding to $\nu = 2/3$, $\mu = 1/3$ are substituted in expansion (6.13). Reordering of this expansion yields

$$\bar{\phi}_V^{(m)} = v^{(0)}(\xi, \eta) + \epsilon^{1/3} v^{(1/3)}(\xi, \eta) + \epsilon^{2/3} v^{(2/3)}(\xi, \eta) + \dots,$$

$$V^{(n/3)}(\xi, \eta) = v_0^{(n/3)}(\xi, \eta) + v_1^{(n/3)}(\xi, \eta) + \dots + v_m^{(n/3)}(\xi, \eta)$$

Let the series

$$Y_n(\xi, \eta) = \hat{Y}_n^{(0)}(\xi, \eta) + \hat{Y}_n^{(1)}(\xi, \eta) + \hat{Y}_n^{(2)}(\xi, \eta) + \dots + \hat{Y}_n^{(m)}(\xi, \eta)$$

express the asymptotic behaviour of $Y_n(\xi, \eta)$ for $\xi\eta = 0(1)$, $\eta \gg 1$. Then the matching condition becomes

$$(6.23) \quad Y_n^{(k)}(\xi, \eta) = V_k^{(n/3)}(\xi, \eta) = O(\eta^{n-3k}), \quad k = 0, 1, 2, \dots, m,$$

$$n = 0, 1, 2, \dots, 3m.$$

Expansion (6.18) is required to have the values $\psi[\varepsilon^{1/3}\eta]$ at the boundary with an accuracy $O(\varepsilon^m)$. When a Taylor expansion of this given function is made, the boundary condition takes the form

$$Y_n(0, \eta) = \psi^{(n)}[0] \eta^{n/n!}.$$

For $n = 0, 1$ explicit solutions are available.

$$(6.24) \quad Y_0(\xi, \eta) = \psi[0]$$

and

$$(6.25) \quad Y_1(\xi, \eta) = R(\xi, \eta)\{\psi'[0] + r(0)\Omega\} - nr(0)\Omega, \quad \Omega = h_0 + g_0\psi[0],$$

where

$$R(\xi, \eta) = -\exp(-1/2\alpha\xi\eta - 1/12\beta\eta^3) \cdot \{\omega R_1 + \omega^2 R_2 - \omega^2 R_3 - \omega R_4\}/\gamma.$$

$$R_1(\xi, \eta) = \int_0^\infty \frac{Ai'(x)}{Ai(x)} Ai(x - m\omega\xi) e^{\gamma\eta x \omega^2} dx,$$

$$R_2(\xi, \eta) = \int_0^\infty \frac{Ai'(x)}{Ai(x)} Ai(x - m\omega^2\xi) e^{\gamma\eta x \omega} dx,$$

$$R_3(\xi, \eta) = \int_0^\infty \frac{Ai'(\omega x)}{Ai(\omega x)} Ai(\omega x - m\omega\xi) e^{\gamma\eta x} dx,$$

$$R_4(\xi, \eta) = \int_0^\infty \frac{Ai'(\omega^2 x)}{Ai(\omega^2 x)} Ai(\omega^2 x - m\omega^2\xi) e^{\gamma\eta x} dx.$$

$Ai(z)$ represents the Airy function with argument z and $Ai'(z)$ derivative,

$$\begin{aligned} \omega &= \exp(2/3\pi i), & \alpha &= (r(0)-r_2(0)) / (c_0 r(0)), \\ \omega^2 &= \exp(-2/3\pi i), & \beta &= r(0)\alpha^2, \\ m^3 &= \alpha/(2c_0 r(0)), & \gamma &= c_0 r(0)m^2. \end{aligned}$$

$R(\xi, \eta)$ satisfies the homogeneous equation of (2.15) and has the boundary values $R(0, \eta) = \eta$ (see appendix A).

The reader will notice that the matching conditions are indeed satisfied, we verify the first two terms

$$U_0^{(0)}(\xi, \eta) = V_0^{(0)}(\xi, \eta) = Y_0^{(0)}(\xi, \eta) = \psi[0],$$

$$U_0^{(1/3)}(\xi, \eta) = Y_1^{(0)}(\xi, \eta) = -\sqrt{\eta^2 + 2\xi(r(0)-r_2(0))}^{-1} \cdot \{\psi'[0] + r(0)\Omega\} - nr(0)\Omega,$$

$$V_0^{(1/3)}(\xi, \eta) = \hat{Y}_1^{(0)}(\xi, \eta) = Y_1^{(0)}(0, \eta) + 2\eta\{\psi'[0] + r(0)\Omega\} \cdot \exp\left\{-\xi\eta \frac{r(0)-r_2(0)}{c_0 r(0)}\right\},$$

(see appendix B).

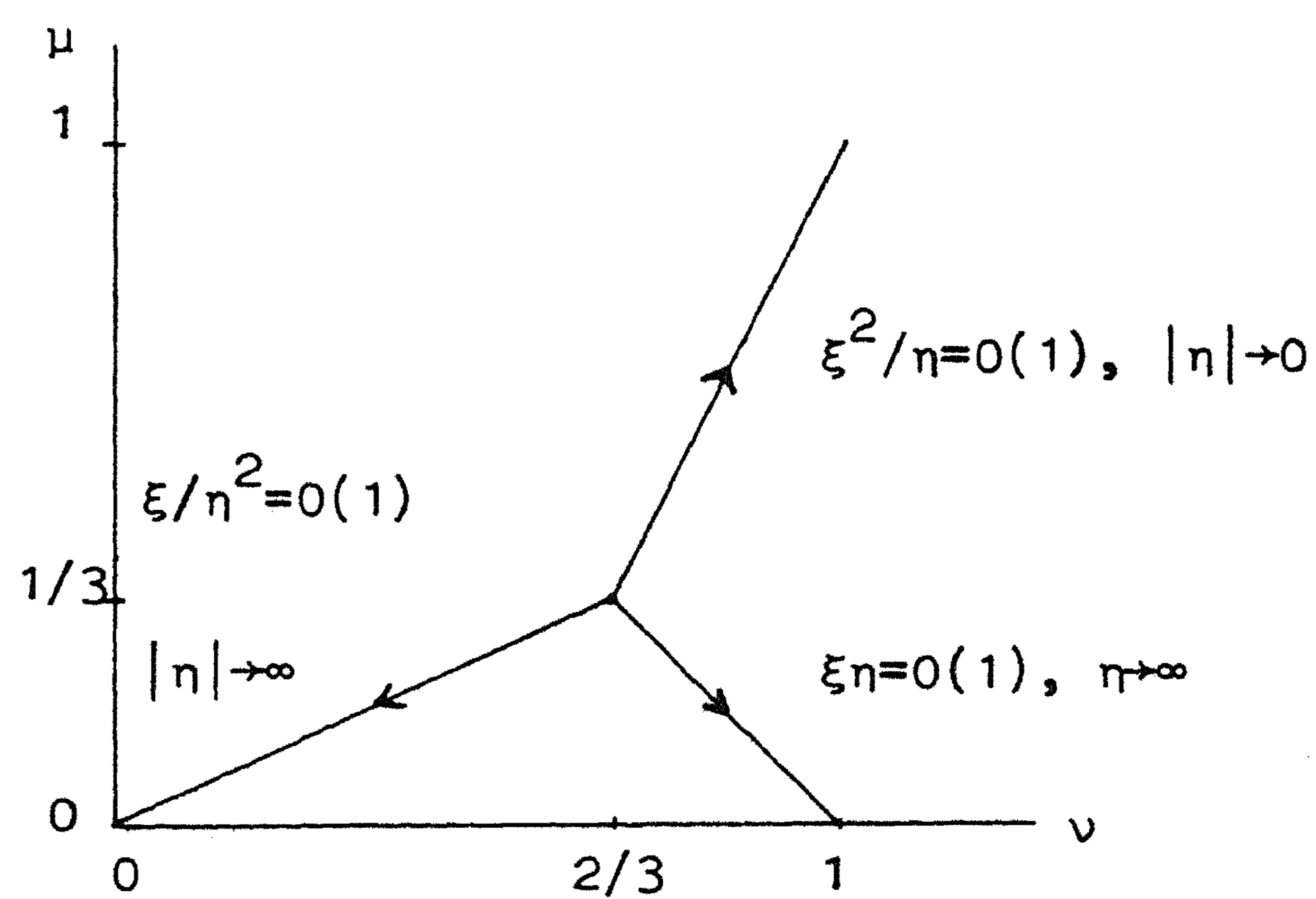

fig. 6.4

d. Interior boundary layer expansion

In this case the values $\nu = 1$, $\mu = 1$ are substituted in (6.7). The coefficients a, \dots, h are expanded as follows.

$$(6.23a) \quad a(\varepsilon\xi, \varepsilon\eta) = a_0 + \varepsilon a_1(\xi, \eta) + \dots + \varepsilon^{m+1} a_{m+1}(\bar{\xi}, \bar{\eta}),$$

.

$$(6.23h) \quad h(\varepsilon\xi, \varepsilon\eta) = h_0 + \varepsilon h_1(\xi, \eta) + \dots + \varepsilon^{m+1} h_{m+1}(\bar{\xi}, \bar{\eta}).$$

The differential operator L_ε becomes in expanded form

$$\varepsilon L_\varepsilon \equiv K_0 + \varepsilon K_1 + \varepsilon^2 K_2 + \dots + \varepsilon^{m+1} K_m,$$

$$K_0 \equiv \frac{a_0}{r(0)^2} \frac{\partial^2}{\partial \eta^2} - \frac{2b_0}{r(0)} \frac{\partial^2}{\partial \xi \partial \eta} + c_0 \frac{\partial^2}{\partial \xi^2} - \frac{1}{r(0)} \frac{\partial}{\partial \eta}.$$

It is supposed that an expansion exists of the type

$$(6.24) \quad \phi_W^{(m)} = \sum_{n=0}^m W_n(\xi, \eta) \varepsilon^n,$$

so that $W_n(\xi, \eta)$ satisfy the equations

$$(6.25) \quad K_0 W_0 = 0, \quad K_0 W_n = - \sum_{i=1}^n K_i W_{n-i} + h_{n-1}(\xi, \eta), \quad n = 1, 2, \dots, m,$$

and the boundary conditions

$$W_n(0, \eta) = \psi^{(n)}[0] \eta^n / n!, \quad n = 1, 2, \dots, m.$$

For $n = 0, 1$ we obtain the solutions

$$W_0(\xi, \eta) = \psi[0],$$

$$W_1(\xi, \eta) = W_1^{(h)}(\xi, \eta) - nr(0)\Omega, \quad (\Omega = h_0 + g_0 \psi[0])$$

$$W_1^{(h)}(\xi, \eta) = \frac{ku}{\pi} \int_{-\infty}^{+\infty} e^{k(v-p)} f_1\left(\frac{p\xi}{r(0)}\right) \frac{K_1(kr)}{r} dp,$$

$$r = \sqrt{u^2 + (v-p)^2}, \quad k = 1/2c_0 / (a_0c_0 - b_0^2),$$

$$u = 1/2 i(\lambda_1 - \lambda_2)\xi,$$

$$v = 1/2 (\lambda_1 + \lambda_2)\xi + r(0)\eta,$$

$$\lambda_{1,2} = (-b_0 \mp i \sqrt{a_0c_0 - b_0^2}) / c_0.$$

$K_1(z)$ denotes a modified Bessel function with argument z . The function $f_1(z)$ has to be bounded and continuous with $f_1(0) = 0$ and $f_1'(0) = (\Omega + \psi'[0])r(0)$. A function that satisfies these conditions is $f_1(z) = f_1'(0)ze^{-z}$.

Finally, we study the matching conditions for the interior boundary-layer expansion and the intermediate boundary-layer expansion. In (6.24) the local coordinates corresponding to $v = 2/3$, $\mu = 1/3$ are introduced, so that

$$\begin{aligned} \Phi_W^{(m)} = & W_0^{(0)} + \varepsilon^{1/3} \{W_1^{(1/3)} + W_2^{(1/3)} + \dots + W_m^{(1/3)}\} + \\ & + \varepsilon^{2/3} \{W_1^{(2/3)} + W_2^{(2/3)} + \dots + W_m^{(2/3)}\} + \dots \end{aligned}$$

Let

$$Y_n(\xi, \eta) = Y_n^{(0)}(\xi, \eta) + Y_n^{(1)}(\xi, \eta) + Y_n^{(2)}(\xi, \eta) + \dots$$

constitute an asymptotic expansion of $Y_n(\xi, \eta)$ for $\eta/\xi^2 = o(1)$, $0 < \xi \ll 1$. It appears that the matching condition is satisfied, if

$$Y_n^{(k)}(\xi, \eta) = W_{(n+n_0+3k)/3}^{(n/3)} = o(\xi^{n_0+3k}),$$

$$\begin{aligned}
 n_0 = 1 & \quad \text{if} \quad n = 2, 5, 8, \dots, \\
 n_0 = 2 & \quad \text{if} \quad n = 1, 4, 7, \dots, \\
 n_0 = 3 & \quad \text{if} \quad n = 3, 6, 9, \dots
 \end{aligned}$$

We remark that indeed

$$Y_1^{(0)}(\xi, \eta) = W_1^{(1/3)}(\xi, \eta) = \left(\eta + \frac{\xi^2}{2r(0)c_0} \right) (\psi'[0] + \Omega r(0)) - \eta \Omega r(0),$$

see appendix C.

6.3 UNIFORMLY VALID EXPANSIONS

In this section an expansion for the solution is constructed, which holds uniformly in \bar{G} .

First, a formal uniform is composed of the significant formal approximations. For that purpose, the results of the matching method are utilized to reorder the local expansions in such a way that expansions with regular coefficients can be obtained.

Next, it is proved that the first three terms of the formal composite expansion approximate the solution $\bar{\phi}(x, y; \varepsilon)$ with an accuracy $O(\varepsilon)$.

Until so far we only studied formal local approximations which hold in a neighbourhood of A. We also have to investigate the formal local approximations holding in a neighbourhood of B, since we have the intention to construct a formal uniformly valid approximation. With a similar analysis it can be shown, that the same types of local expansions arise near B. In the sequel, the expression

$$\bar{\phi}_y^{(m)} = \sum_{n=0}^{3m} Y_n \varepsilon^{n/3}$$

represents an intermediate boundary-layer expansion near A and B: i.e.

$$Y_n = Y_n^{(A)} + Y_n^{(B)},$$

where $Y_n^{(A)}(\xi, \eta)$ has the form of (6.18). The function $Y_n^{(B)}$ has a same form $Y_n^{(B)}(\bar{\xi}, \bar{\eta})$, where $\bar{\xi}, \bar{\eta}$ follows from

$$x = (r(\bar{\theta}) - \bar{\rho}) \sin \bar{\theta} + x_B,$$

$$y = (r(\bar{\theta}) - \bar{\rho}) \cos \bar{\theta},$$

$$\pi - \bar{\theta} = \bar{\eta} \epsilon^{1/3}, \quad \bar{\rho} = \bar{\xi} \epsilon^{2/3}.$$

Similar assumptions have been made for the interior boundary layer expansion and for the matching terms.

The ordinary boundary layer functions $V_n(\rho/\epsilon, \theta)$ are exponentially increasing in the left part of the domain G . In order to express these boundary layer terms as functions defined in the whole domain G we multiply them by an infinitely differentiable smoothing factor $K(\rho/\rho_0)$, which is defined in \bar{G} as follows.

Outside a neighbourhood of Γ_r it equals zero, inside a neighbourhood of Γ_r we distinguish three cases for $\epsilon^{1/3} < \theta < \theta_B - \epsilon^{1/3}$

- a. $0 \leq \rho \leq 1/3\rho_0$, where $K(\rho/\rho_0) = 1$,
- b. $1/3\rho_0 \leq \rho \leq 2/3\rho_0$, where $K(\rho/\rho_0)$ is monotonic decreasing from one to zero,
- c. $2/3\rho_0 \leq \rho \leq \rho_0$, where $K(\rho/\rho_0) = 0$.

Thus in the sequel the following expression for the ordinary boundary layer function is used

$$\bar{V}_n(\rho/\epsilon, \theta) = K(\rho/\rho_0) V_n(\rho/\epsilon, \theta).$$

Before continuing our analysis we summarize the results of the preceding section.

- a. We have obtained an approximation of the solution, which holds outside neighbourhoods of the points A and B:

$$(6.26) \quad \phi(x,y;\epsilon) = \sum_{n=0}^m \{U_n(x,y) + \bar{V}_n(\rho/\epsilon, \theta)\} \epsilon^n + Z_m(x,y;\epsilon).$$

In [7] it is proved that $Z_m(x,y;\epsilon) = o(\epsilon^{m+1})$ uniformly in \bar{G} apart from small neighbourhoods of A and B.

- b. Near the points A and B we obtained formal local approximations, which we called intermediate and interior boundary layer expansions.
- c. By means of matching methods conditions were derived for the terms of the expansions mentioned in a and b.

In figure 6.5a we show in a suggestive picture the domains corresponding with the various expansions. The lines separating these domains are determined by the thickness (in order of magnitude of ϵ) of the boundary layers (see figure 6.5b). The values of ν, μ of figure 6.5b correspond with the values from formula (6.7).

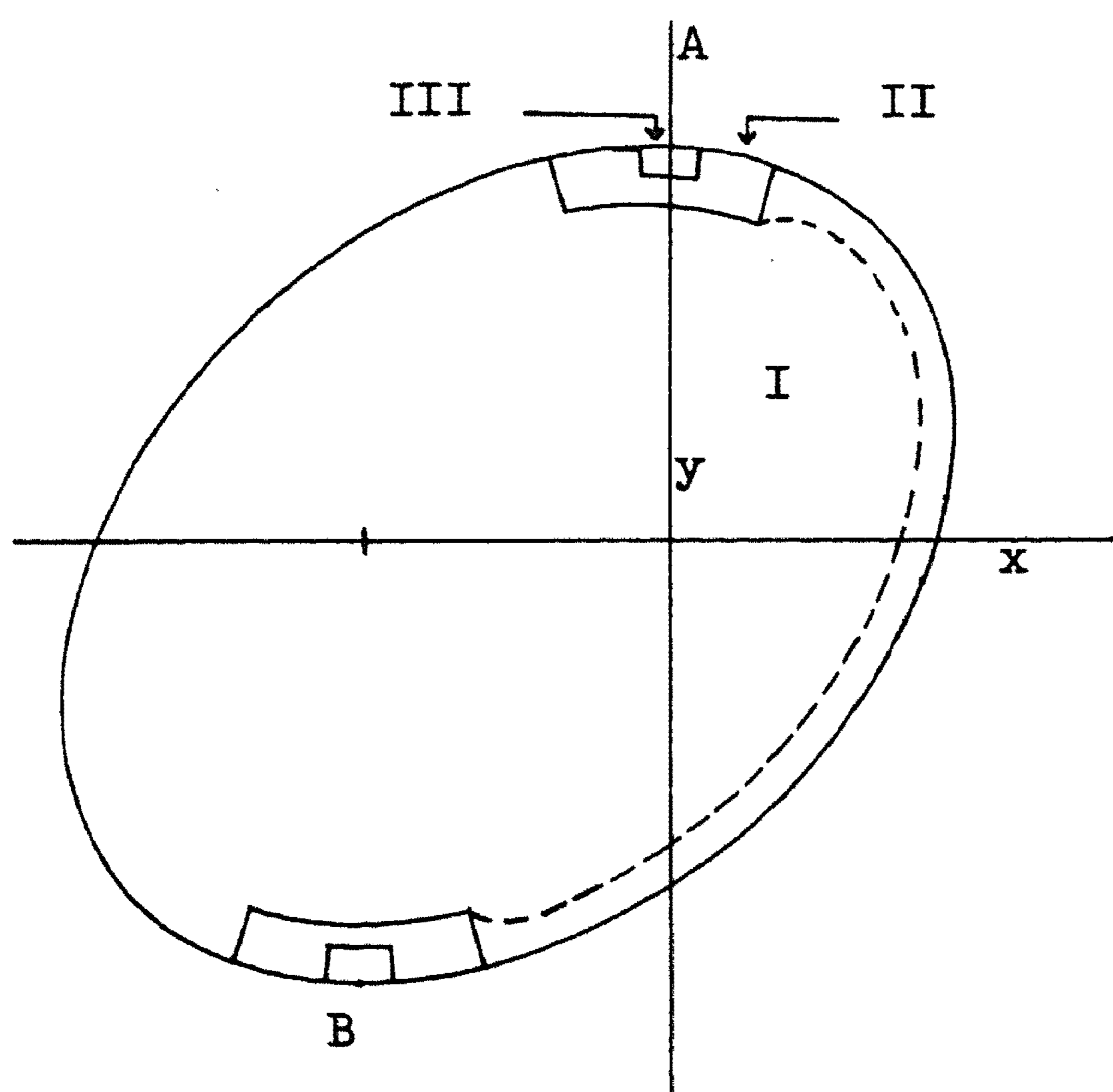

fig. 6.5a

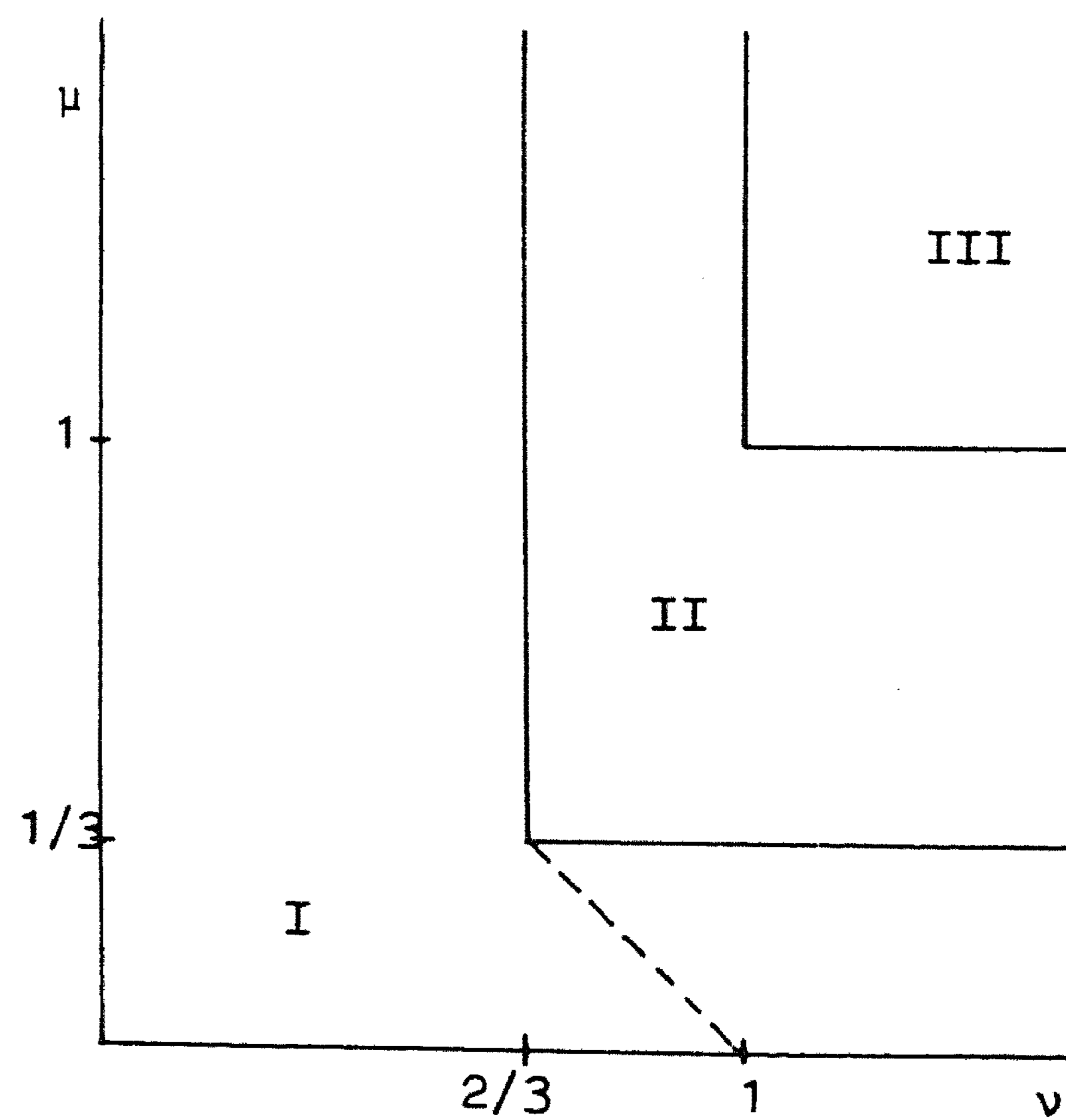

fig. 6.5b

Step by step a formal asymptotic uniform approximation is composed. Expansion (6.26) is reordered and the terms $U_k^{(n/3)}$, $\bar{V}_k^{(n/3)}$ which were obtained with the matching method are put forwards in the series

$$(6.27) \quad \Phi = U_0 + \bar{V}_0 + \varepsilon^{1/3}(U_1^{(1/3)} + \bar{V}_1^{(1/3)} + U_2^{(1/3)} + \bar{V}_2^{(1/3)} + \dots) + \\ \varepsilon^{2/3}(U_1^{(2/3)} + \bar{V}_1^{(2/3)} + U_2^{(2/3)} + \bar{V}_2^{(2/3)} + \dots) + \\ \varepsilon(U_1 - U_1^{(1/3)} - U_1^{(2/3)} + \bar{V}_1 - \bar{V}_1^{(1/3)} - \bar{V}_1^{(2/3)} + U_2^{(3/3)} + \bar{V}_2^{(3/3)} + \dots) + \dots$$

Using (6.22) and (6.23) we deduce that Y_n has the following asymptotic behaviour

$$Y_n = U_0^{(n/3)} + \bar{V}_0^{(n/3)} + U_1^{(n/3)} + \bar{V}_1^{(n/3)} + U_2^{(n/3)} + \bar{V}_2^{(n/3)} + \dots$$

Considering these relations we introduce an expansion, which is identical to (6.27) in domain I and to (6.18) in domain II.

$$(6.28) \quad \Phi = U_0 + \bar{V}_0 + \varepsilon^{1/3}(Y_1 - U_0^{(1/3)} - \bar{V}_0^{(1/3)}) + \varepsilon^{2/3}(Y_2 - U_0^{(2/3)} - \bar{V}_0^{(2/3)}) + \\ \varepsilon(U_1 - U_1^{(1/3)} - U_1^{(2/3)} + \bar{V}_1 - \bar{V}_1^{(1/3)} + \\ Y_3 - U_0^{(3/3)} - \bar{V}_0^{(3/3)} - U_1^{(3/3)} - \bar{V}_1^{(3/3)}) + \dots$$

Finally, we are able to construct an expansion, which is identical to (6.28) in I and II and to the interior boundary layer expansion (6.24) in III.

$$(6.29) \quad \Phi = U_0 + \bar{V}_0 + \varepsilon^{1/3}(Y_1 - U_0^{(1/3)} - \bar{V}_0^{(1/3)}) + \varepsilon^{2/3}(Y_2 - U_0^{(2/3)} - \bar{V}_0^{(2/3)}) + \\ \varepsilon(U_1 - U_1^{(1/3)} - U_1^{(2/3)} + \bar{V}_1 - \bar{V}_1^{(1/3)} - \bar{V}_1^{(2/3)} + \\ Y_3 - U_0^{(3/3)} - \bar{V}_0^{(3/3)} - U_1^{(3/3)} - \bar{V}_1^{(3/3)} + W_1 - W_1^{(1/3)} - W_1^{(2/3)}) + \dots$$

Expansion (6.29) has all properties desired for the function $\phi(x,y;\varepsilon)$ such as exponential decay near the boundary Γ_r and an "Airy function" behaviour near A and B, which forms a linkage between the interior solution expressed in modified Bessel functions and the solution outside neighbourhoods of A and B.

However, until so far we did not prove that a finite number of terms of (6.29) approximates the function $\phi(x,y;\varepsilon)$ with some accuracy in ε . We will prove that

$$(6.30) \quad \phi = U_0 + V_0 + \varepsilon^{1/3}(Y_1 - U_0^{(1/3)} - \bar{V}_0^{(1/3)}) + \varepsilon^{2/3}(Y_2 - U_0^{(2/3)} - \bar{V}_0^{(2/3)}) + \\ \varepsilon(\bar{V}_1 - \bar{V}_1^{(1/3)} - \bar{V}_1^{(2/3)} + Y_3 - U_0^{(3/3)} - \bar{V}_0^{(3/3)} - \bar{V}_1^{(3/3)}) + Z,$$

where $Z(x,y;\varepsilon) = o(\varepsilon)$ uniformly in \bar{G} .

For this purpose a theorem of Eckhaus and De Jager [7] is reproduced, which forms an application of the maximum principle.

Theorem 6.1 Let $\phi(x,y;\varepsilon)$ be the solution of the boundary value problem

$$L_\varepsilon \phi = h_\varepsilon(x,y;\varepsilon)$$

valid in a bounded domain G with

$$\phi|_\Gamma = \psi_\varepsilon(x,y;\varepsilon)$$

along the boundary Γ of G . If

$$h_\varepsilon(x,y;\varepsilon) = o(\varepsilon^\alpha) \text{ in } \bar{G}, \quad \alpha \geq 0,$$

and

$$\psi_\varepsilon(x,y;\varepsilon) = o(\varepsilon^\beta) \text{ along } \Gamma, \quad \beta \geq 0,$$

then at most

$$\phi(x,y;\varepsilon) = o(\varepsilon^{\min(\alpha,\beta)}) \text{ in } \bar{G}.$$

Substitution of (6.30) in (6.3) yields

$$(6.31) \quad L_\varepsilon Z = -[\varepsilon(L_2 U_0 + \bar{M}_2 \bar{V}_0 + \bar{M}_1 \bar{V}_1 + \bar{T}_3 Y_1 + \bar{T}_2 Y_2 + \bar{T}_1 Y_3) + \\ h_0 + h_1 \theta + 1/2 h_{\theta\theta} \theta^2 + h_\rho \rho - L_\varepsilon \{ \varepsilon^{1/3} (U_0^{(1/3)} + \bar{V}_0^{-(1/3)} + \bar{V}_1^{-(1/3)}) + \\ \varepsilon^{2/3} (U_0^{(2/3)} + \bar{V}_0^{(2/3)} + \bar{V}_1^{(2/3)}) + \varepsilon (U_0^{(3/3)} + \bar{V}_0^{-(3/3)} + \bar{V}_1^{-(3/3)}) \}],$$

moreover it follows from (6.30) that

$$Z|_\Gamma = O(\varepsilon).$$

The right-hand side of (6.31) contains singular terms, but it will be proved that all these singularities cancel out.

The following properties of the local expansion terms will be used in order to prove that

$$L_\varepsilon(Z) = O(\varepsilon)$$

uniformly in \bar{G} .

a. The expressions

$$K_1 = \bar{T}_3 (Y_1 - U_0^{(1/3)} - \bar{V}_0^{-(1/3)} - \bar{V}_1^{-(1/3)}),$$

$$K_2 = \bar{T}_2 (Y_2 - U_0^{(2/3)} - \bar{V}_0^{(2/3)} - \bar{V}_1^{(2/3)}),$$

$$K_3 = \bar{T}_1 (Y_3 - U_0^{(3/3)} - \bar{V}_0^{(3/3)} - \bar{V}_1^{(3/3)})$$

are bounded in \bar{G} , so that a number M independent of ε exists such that $\max\{|K_1|, |K_2|, |K_3|\} \leq M$.

b. In appendix D we prove that

$$\begin{aligned}
& h_0 + h_1 \theta + 1/2 h_{\theta\theta} \theta^2 + h_\rho \rho + \\
& (\varepsilon^{-1/3} T_0 + T_1 + \varepsilon^{1/3} T_2) \varepsilon^{1/3} (U_0^{(1/3)} \bar{V}_0^{(1/3)} + \bar{V}_1^{(1/3)}) + \\
& (\varepsilon^{-1/3} T_0 + T_1) \varepsilon^{2/3} (U_0^{(2/3)} \bar{V}_0^{(2/3)} + \bar{V}_1^{(2/3)}) + \\
& (\varepsilon^{-1/3} T_0) \varepsilon (U_0^{(3/3)} \bar{V}_0^{(3/3)} + \bar{V}_1^{(3/3)}) = \\
& \text{Sing}\{L_2 U_0\} + \text{Sing}\{\bar{M}_2 \bar{V}_0\} + \text{Sing}\{\bar{M}_1 \bar{V}_1\} + Z,
\end{aligned}$$

where

$$Z = O(\varepsilon^N) \text{ for } 1/3\rho_0 < \rho < 2/3\rho_0, \quad \varepsilon^{1/3} < \theta < \theta_B - \varepsilon^{1/3}$$

(N arbitrary large)

$$Z = 0 \text{ elsewhere in } \bar{G}.$$

$\text{Sing}\{S(x,y;\varepsilon)\}$ denotes the singular terms of a development of $S(x,y;\varepsilon)$ near A (and B).

The contribution to the right-hand side of (6.31) comes from the regular parts of $L_2 U_0$, $\bar{M}_2 \bar{V}_0$, $\bar{M}_1 \bar{V}_1$ and from K_1 , K_2 and K_3 . Thus we find that $L_\varepsilon Z = O(\varepsilon)$ in \bar{G} .

Applying the theorem mentioned above we may conclude that $Z(x,y;\varepsilon) = O(\varepsilon)$ uniformly in \bar{G} . We remark that a same accuracy is obtained when the term of $O(\varepsilon)$ is omitted in (6.30).

It is emphasized that an estimate of the remainder term of a truncated formal uniform expansion can only be made with the maximum principle, if the last term of the truncated expansion is of order $O(\varepsilon^m)$, $m = 1, 2, \dots$. In this last term the contribution from the interior boundary-layer expansion can be omitted.

6.4 HIGHER ORDER TANGENCY

It appears that the order of tangency in the points A and B determines the composition of the uniformly valid approximation. Therefore, we study this tangency in detail

In a neighbourhood of A the coordinates of the boundary

$$x = r(\theta)\sin \theta, \quad y = r(\theta)\cos \theta$$

are expanded for small θ

$$\begin{aligned} x &= r(0)\theta + \left(\frac{r_2(0)}{2!} - \frac{r(0)}{3!}\right)\theta^3 + \dots, \\ y &= r(0) + \left(\frac{r_2(0)}{2!} - \frac{r(0)}{2!}\right)\theta^2 + \frac{r_3(0)}{3!}\theta^3 + \\ &\quad + \left(\frac{r_4(0)}{4!} - \frac{r_2(0)}{2!2!} + \frac{r(0)}{4!}\right)\theta^4 + \dots \end{aligned}$$

In the preceding sections we considered the case $r(0) > r_2(0)$ which agrees with the relation

$$x = r(0)\sqrt{\frac{2}{r(0)-r_2(0)}}\sqrt{r(0)-y} + o((r(0)-y))$$

between the coordinates of the boundary near A (see also Višik and Lyusternik [34]).

From now on we also consider the case where the tangency of the characteristic of L_1 to the boundary in A is of higher order. Let

$$y = r(0) - k_2^{(n)}\theta^2 - k_3^{(n)}\theta^3 - k_4^{(n)}\theta^4 - k_5^{(n)}\theta^5 - \dots,$$

and $k_2^{(n)} = k_3^{(n)} = \dots = k_{2n-1}^{(n)} = 0$, $k_{2n}^{(n)} > 0$, then the tangency is of the order $2n - 1$. This leads to the following relation between the coordinates of the boundary near A

$$x = r(0) \sqrt[2n]{(k_{2n}^{(n)})^{-1}} (r(0)-y)^{\frac{1}{2n}}$$

An analogous argument holds for the tangency in B.

In comparing the local expansions for different orders of tangency we see one important change, i.e. the intermediate boundary layer. Firstly, the intermediate boundary layer arises for other values of ν and μ (see formula (6.7)), and secondly, the local equation (and therefore also the local expansion) is different. Thus, the intermediate boundary layer is determined by the order of tangency.

Let (ν_n, μ_n) be the point in the ν, μ -plane that corresponds to the intermediate boundary layer equation in case of $(2n-1)$ th order of tangency. Then the differential operator $\varepsilon^{\mu_n} L_\varepsilon$ is expanded as follows

$$\varepsilon^{\mu_n} L_\varepsilon \equiv T_0^{(n)} + \varepsilon^{\mu_n} T_1^{(n)} + \varepsilon^{2\mu_n} T_2^{(n)} + \dots,$$

$$T_0^{(n)} \equiv c_0 \varepsilon^{1-2\nu_n+\mu_n} \frac{\partial^2}{\partial \xi^2} + \varepsilon^{\mu_n-\nu_n} X_0^{(n)} - \frac{1}{r(0)} \frac{\partial}{\partial \eta}.$$

We take $1 - 2\nu_n + \mu_n = 0$, so that the first and third term of $T_0^{(n)}$ are of the same order of magnitude in ε . $X_0^{(n)}$ is the first term of the expanded operator

$$- \left\{ \frac{r'(\eta \varepsilon^{\mu_n}) \cos \eta \varepsilon^{\mu_n}}{r(\eta \varepsilon^{\mu_n}) - \xi \varepsilon^{\nu_n}} - \sin(\eta \varepsilon^{\mu_n}) \right\} \frac{\partial}{\partial \xi}.$$

For the $(2n-1)$ th order of tangency the following expression for $X_0^{(n)}$ is computed

$$X_0^{(n)} \equiv k_{2n}^{(n)} \eta^{2n-1} \varepsilon^{(2n-1)\mu_n} \frac{\partial}{\partial \xi}.$$

The term $\varepsilon^{\mu_n-\nu_n} X_0^{(n)}$ is of the order $O(1)$, if $\mu_n - \nu_n + (2n-1)\mu_n = 0$. Since the condition $1 - 2\nu_n + \mu_n = 0$ also exists, we obtain for ν_n, μ_n the values

$$\nu_n = \frac{2n}{4n-1}, \quad \mu_n = \frac{1}{4n-1}.$$

A diagram as figure 6.2 can be made. When these diagrams are brought in one figure (fig. 6.6), we observe that

- a. $\lim_{n \rightarrow \infty} (v_n, \mu_n) = (1/2, 0)$,
- b. in order to match the intermediate boundary layer and the outer expansion we need to introduce limits of the type $\xi/\eta^{2n} = 0(1)$, $|\eta| \rightarrow \infty$,
- c. in order to match the intermediate boundary layer and the ordinary boundary layer expansion we have to introduce limits of the type $\xi\eta^{2n-1} = 0(1)$, $\eta \rightarrow \infty$.

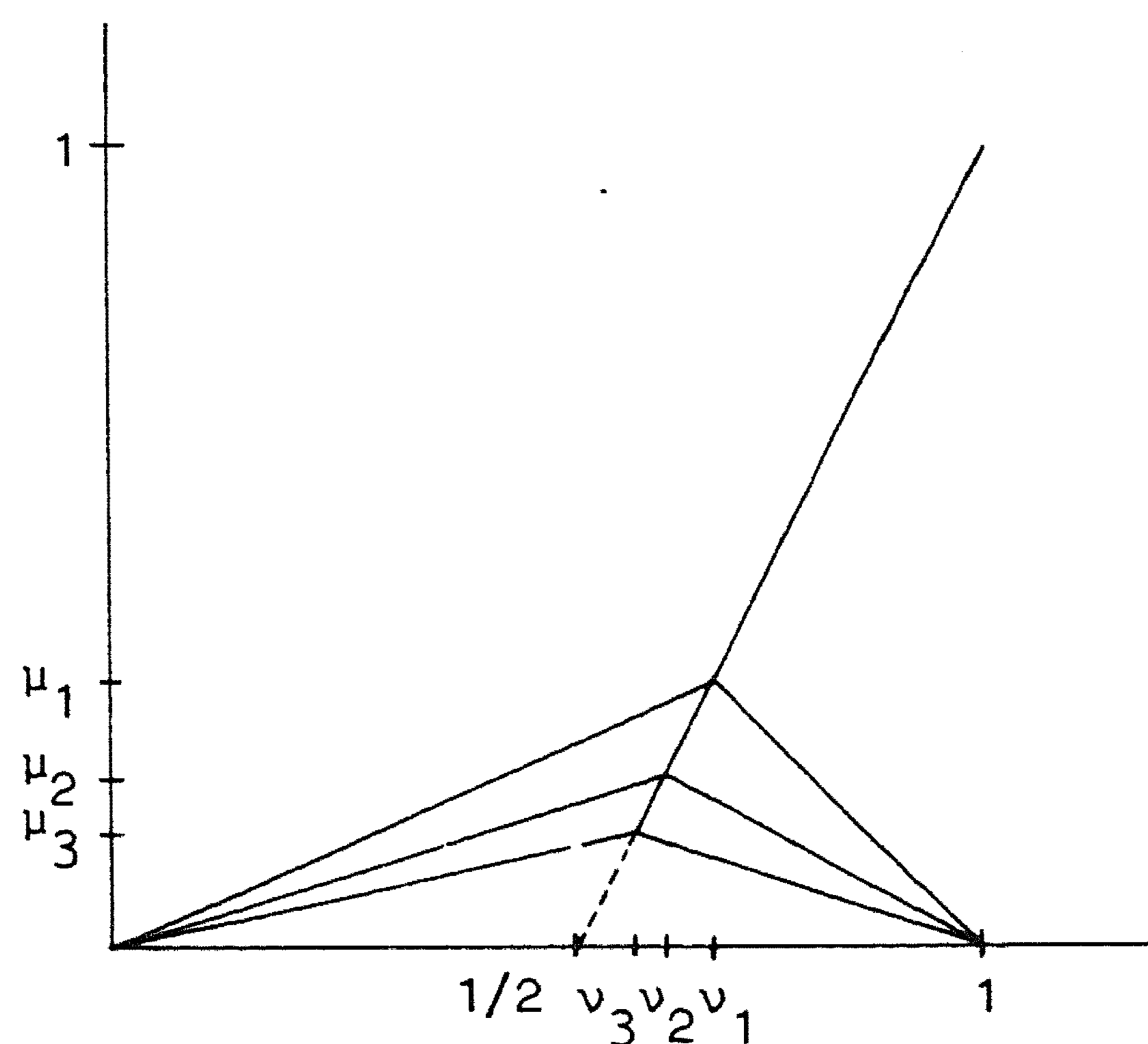

fig. 6.6

In the point $(v, \mu) = (1/2, 0)$ the intermediate boundary layer equation degenerates to a parabolic equation

$$\left(c_0 \frac{\partial^2}{\partial \xi^2} - \frac{1}{r(0)} \frac{\partial}{\partial \eta} - g_0 \right) Y_1 = h_0.$$

It is easily deduced that this parabolic equation forms a local representation of a parabolic boundary layer equation, which is obtained from (6.3) by stretching the y -coordinate, $y = r(0) - \xi_p \varepsilon^{1/2}$, and letting ε tend to

zero (see figure 6.7).

$$(c(x,r(0)) \frac{\partial^2}{\partial \xi_p^2} - \frac{\partial}{\partial x} - g(x,r(0))) Y_p = h(x,r(0)).$$

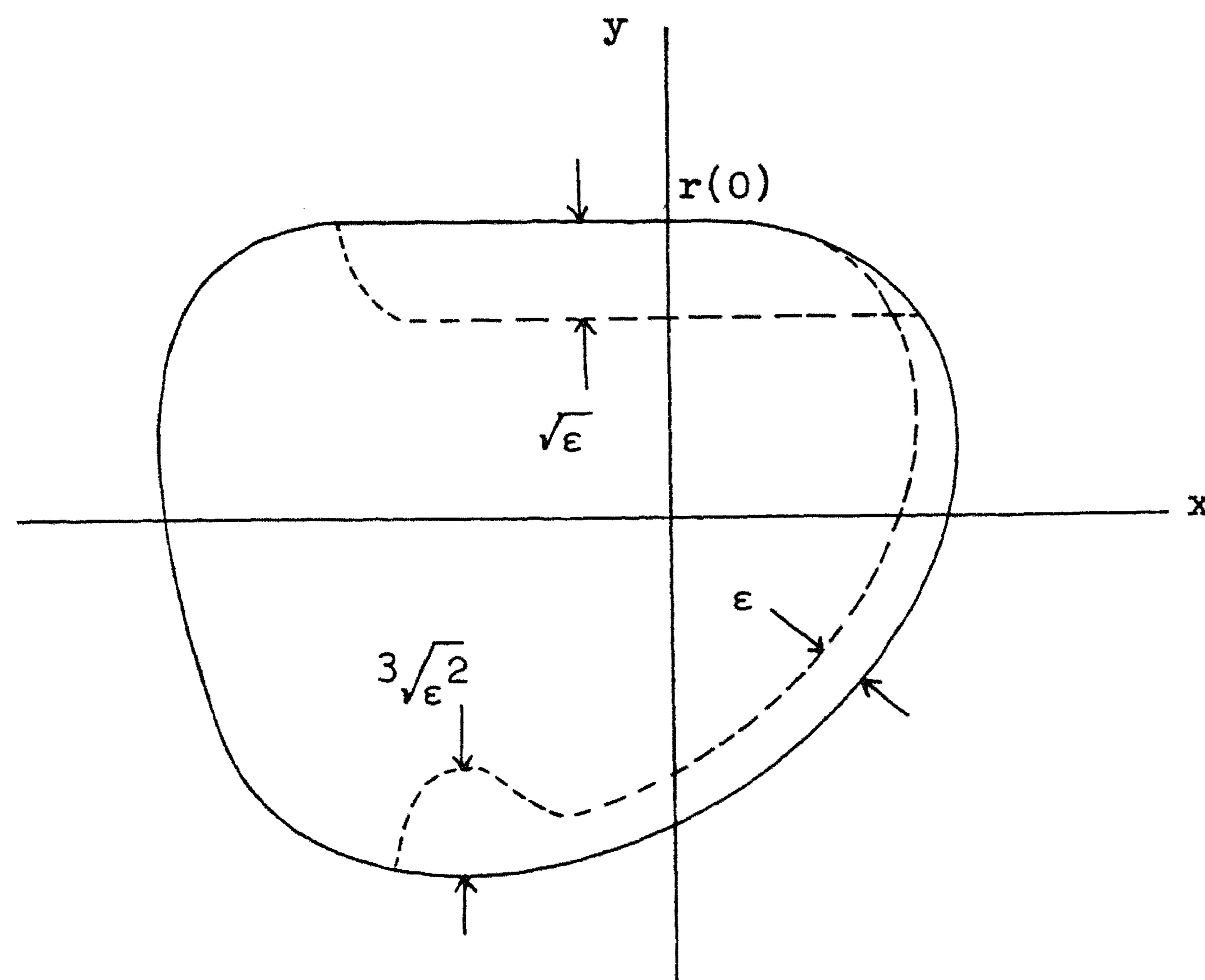

fig. 6.7

Returning to finite n we suppose that an intermediate boundary layer expansion exists of the type

$$\phi_y^{(m)} = Y_0^{(n)} + \epsilon^{\mu} Y_1^{(n)} + \epsilon^{2\mu} Y_2^{(n)} + \dots + \epsilon^{m/\mu} Y_{m/\mu}^{(n)}.$$

Remark Exactly, as in the case of first order tangency a particular solution of the homogeneous intermediate boundary layer equation is available. For example for $n = 2$ we have

$$\text{Ai}(x - m\xi + s_2(n)) \cdot \exp[-1/2\alpha\xi n + \gamma n x + t_2(n)],$$

$$s_2(n) = 1/2k_2^{(1)} n^2 - 1/4mk_4^{(2)} n^4,$$

$$t_2(\eta) = (1/4k_2^{(1)}\alpha + 1/12\beta)\eta^3 - 1/8\alpha k_4^{(2)}\eta^5.$$

With the aid of this particular solution we can determine $Y_k^{(n)}$ such that it satisfies all conditions.

Let the order of tangency in A be $2n_A - 1$ and in B $2n_B - 1$. Following section 6.3 the remainder term $Z(x,y;\varepsilon)$ of

$$\begin{aligned} \Phi = & U_0 + \bar{V}_0 + \varepsilon^{\mu_A} \{ Y_1^{(n_A)} - U_0^{(\mu_A)} - \bar{V}_0^{(\mu_A)} \} + \varepsilon^{\mu_B} \{ Y_1^{(n_B)} - U_0^{(\mu_B)} - \bar{V}_0^{(\mu_B)} \} + \\ & \varepsilon^{2\mu_A} \{ \dots + \varepsilon \{ \bar{V}_1 - \bar{V}_1^{(\mu_A)} \} \dots - \bar{V}_1^{(1-\mu_A)} - \bar{V}_1^{(\mu_B)} \dots - \bar{V}_1^{(1-\mu_B)} + \\ & Y_{1/\mu_A}^{(n_A)} - U_0^{(\mu_A/\mu_A)} - \bar{V}_0^{(\mu_A/\mu_A)} + Y_{1/\mu_B}^{(n_B)} - U_0^{(\mu_B/\mu_B)} - \bar{V}_0^{(\mu_B/\mu_B)} - \bar{V}_1^{(\mu_B/\mu_B)} \} + Z. \end{aligned}$$

can be estimated.

The proof that $Z = O(\varepsilon)$ uniformly in \bar{G} is similar to the proof given in section 6.3.

The following statement is a direct consequence of the foregoing.

If the order of tangency in A is $(2n_A-1)$ and in B $(2n_B-1)$, then

$$\Phi = U_0 + \bar{V}_0 + O(\varepsilon^{\min(\frac{1}{4n_A-1}, \frac{1}{4n_B-1})})$$

uniformly in \bar{G} . Frankena [11] estimated the remainder term

$$O(\varepsilon^{\min(\frac{1}{4n_A}, \frac{1}{4n_B})}).$$

6.5 A MAGNETOHYDRODYNAMICAL PROBLEM

The mathematical problem we dealt with in this chapter is concerned with parallel flow of conducting fluid along an insulating pipe of circular cross-section perpendicular to which a uniform magnetic field B_0 is applied. The system satisfies the modified Navier-Stokes equation and the induction

equation (see Gold [13]). This problem is reduced to that of solving the equations

$$\frac{\partial^2 v}{\partial x^2} + \frac{\partial^2 v}{\partial y^2} - M \frac{\partial b}{\partial x} = -1,$$

$$\frac{\partial^2 b}{\partial x^2} + \frac{\partial^2 b}{\partial y^2} - M \frac{\partial v}{\partial x} = 0,$$

with the boundary values

$$v = b = 0 \quad \text{on} \quad r = 1.$$

The variables v and b denote the velocity of flow and the induced magnetic field, both in a direction normal to the x,y -plane. The constant M represents the Hartmann number

$$M = B_0(\sigma/\rho\nu)^{1/2},$$

where ρ and ν are the density and the viscosity of the fluid and σ is its electrical conductivity.

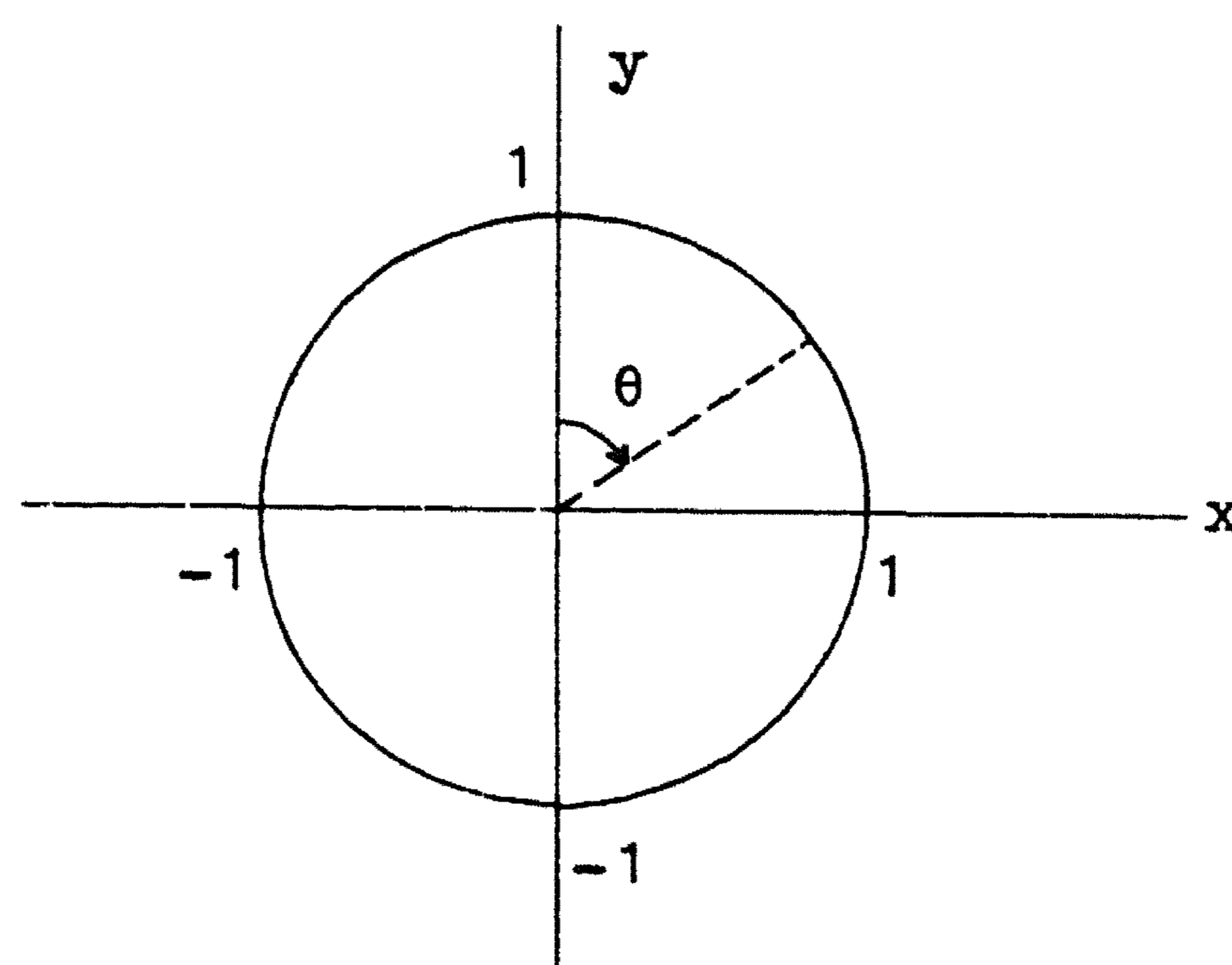

fig. 6.8

Because of the symmetry with respect to the x-axis, it is sufficient to solve the problem

$$(6.32a) \quad \Delta\phi - M \frac{\partial\phi}{\partial x} = -1$$

$$(6.32b) \quad \phi = 0 \quad \text{on} \quad r = 1,$$

$$v(x,y) = v(-x,y) = 1/2[\phi(x,y) + \phi(-x,y)],$$

$$b(x,y) = -b(-x,y) = 1/2[\phi(x,y) - \phi(-x,y)].$$

An exact solution of this problem is available

$$(6.33) \quad \phi(r,\theta) = \frac{r \sin\theta}{M} + \exp\left(\frac{-2r \sin\theta}{M}\right) \sum_{n=0}^{\infty} k_n \frac{I'_n\left(\frac{M}{2}\right)}{I_n\left(\frac{M}{2}\right)} I_n\left(\frac{Mr}{2}\right) \sin n\theta,$$

$$x = r \sin\theta, \quad y = r \cos\theta,$$

$$k_n = 1 \quad \text{if} \quad n = 0, \quad k_n = 2 \quad \text{if} \quad n \neq 0.$$

For large values of M expression (6.33) is computationally useless, since the series converges slowly. A first attempt to describe the asymptotic behaviour of (6.33) was made by Shercliff [32]. Roberts [31] gave an approximation for large M, which agrees in great lines with our analysis (see sections 6.1 - 6.2).

The differences are noted in the following three points

1. In [31] it is not evident that the approximation of (6.32) is still singular in (0,1) and (0,-1). It turns out that another boundary layer exists (the interior boundary layer). We must admit, however, that this does not change the value of the net flux of fluid down the pipe for the required accuracy of $O(M^{-7/3})$. The contribution of the interior boundary layer to the net flux is of order $O(M^{-4})$.
2. The matching conditions, that we derived, differ from the ones used by

Roberts. It is worth mentioning that our approach has reduced the number of necessary computations. Conditions (41) and (42) of [31] are replaced by one condition (B.1).

3. By estimating the remainder term, we have shown that the first terms of the formal asymptotic solution indeed approximate $\phi(r, \theta)$.

APPENDIX

APPENDIX A

The problem, studied in this appendix, is formulated as follows.
A function $R(\xi, \eta)$ satisfies the differential equation

$$(A.1) \quad c_0 \frac{\partial^2 R}{\partial \xi^2} + \left(1 - \frac{r_2(0)}{r(0)}\right) \eta \frac{\partial R}{\partial \xi} - \frac{1}{r(0)} \frac{\partial R}{\partial \eta} = 0,$$

and has the boundary values

$$R(0, \eta) = \eta.$$

Moreover, the matching conditions have an effect on the problem. The following asymptotic behaviour is a consequence of it,

$$R(\xi, \eta) = -\sqrt{\eta^2 + 2\xi(r(0) - r_2(0))} \quad \text{for } \xi/\eta^2 = 0(1), \quad |\eta| \gg 1,$$

and

$$R(\xi, \eta) = -\eta + 2\eta \exp\left\{-\xi\eta \frac{r(0) - r_2(0)}{c_0 r(0)}\right\} \quad \text{for } \xi\eta = 0(1), \quad \eta \gg 1.$$

The solution of this problem has been given by Roberts [31]. In great lines it is as follows.

Introduction of a new dependent variable $\Phi(\xi, \eta)$,

$$(A.2) \quad \Phi(\xi, \eta) = \exp(+1/2\alpha\xi\eta + 1/12\beta\eta^3) R(\xi, \eta),$$

$$\alpha = (r(0) - r_2(0)) / (c_0 r(0)), \quad \beta = r(0)\alpha^2,$$

leads to the equation

$$(A.3) \quad c_0 \frac{\partial^2 \Phi}{\partial \xi^2} + c_0 m^3 \xi \Phi = \frac{1}{r(0)} \frac{\partial \Phi}{\partial \eta}, \quad m^3 = \alpha / (2c_0 r(0)),$$

and the boundary condition

$$(A.4) \quad \Phi(0, \eta) = \eta \exp(1/12\beta\eta^3).$$

We note that

$$(A.5a) \quad P_1(\xi, \eta; p) = e^{\gamma\eta p} \text{Ai}(p - m\xi),$$

$$(A.5b) \quad P_2(\xi, \eta; p) = e^{\gamma\eta p} \text{Ai}(\omega p - m\omega\xi),$$

$$(A.5c) \quad P_3(\xi, \eta; p) = e^{\gamma\eta p} \text{Ai}(\omega^2 p - m\omega^2\xi),$$

$$\omega = \exp(2/3\pi i), \quad \omega^2 = \exp(-2/3\pi i), \quad \gamma = c_0 r(0) m^2$$

are solutions of (A.3), where $\text{Ai}(z)$ denotes the Airy function and p an arbitrary constant.

Two of the three solutions (A.5) can be chosen independently. By considering these three solutions together some special properties of Airy functions can be used.

Roberts [31] introduces the solution

$$(A.6) \quad R(\xi, \eta) = -m^{-2} \exp(-1/2\alpha\xi\eta - 1/12\beta\eta^3) \{\omega R_1 + \omega^2 R_2 - \omega^2 R_3 - \omega R_4\} / \gamma,$$

$$R_1(\xi, \eta) = \int_0^\infty \frac{\text{Ai}'(x)}{\text{Ai}(x)} \text{Ai}(x - m\omega\xi) e^{\gamma\eta x \omega^2} dx,$$

$$R_2(\xi, \eta) = \int_0^\infty \frac{\text{Ai}'(x)}{\text{Ai}(x)} \text{Ai}(x - m\omega^2\xi) e^{\gamma\eta x \omega} dx,$$

$$R_3(\xi, \eta) = \int_0^\infty \frac{\text{Ai}'(\omega x)}{\text{Ai}(\omega x)} \text{Ai}(\omega x - m\omega\xi) e^{\gamma\eta x} dx,$$

$$R_4(\xi, \eta) = \int_0^\infty \frac{\text{Ai}'(\omega^2 x)}{\text{Ai}(\omega^2 x)} \text{Ai}(\omega^2 x - m\omega^2\xi) e^{\gamma\eta x} dx.$$

From the theory of Airy functions it is known that for all x

$$(A.7) \quad \text{Ai}(x) + \omega \text{Ai}(\omega x) + \omega^2 \text{Ai}(\omega^2 x) = 0$$

and consequently

$$(A.8) \quad \text{Ai}'(x) + \omega^2 \text{Ai}'(\omega x) + \omega \text{Ai}'(\omega^2 x) = 0,$$

Thus

$$(A.9) \quad R(0, \eta) = -m^{-2} \exp(-1/12\beta\eta^3) \int_0^\infty \text{Ai}'(x) (e^{\gamma\eta x} + \omega e^{\gamma\eta x \omega^2} + \omega^2 e^{\gamma\eta x \omega}) dx.$$

In [31] it is shown that indeed

$$R(0, \eta) = \eta.$$

Moreover, the conditions for the asymptotic behaviour are satisfied, as we will see in appendix B.

APPENDIX B

We prove that

$$(B.1) \quad R(\xi, \eta) = -\sqrt{\eta^2 + 2\xi(r(0) - r_2(0))} \quad \text{for } \xi/\eta^2 = o(1), \quad |\eta| \gg 1.$$

After a changing of integration variables $R(\xi, \eta)$ takes the form

$$(B.2) \quad R(\xi, \eta) = -m^{-2} \exp(-1/12\beta\eta^3) [R_A + R_B + R_C + R_D]$$

$$R_A = \omega \int_0^\infty \frac{\text{Ai}'(m\omega\xi+x)}{\text{Ai}(m\omega\xi+x)} \text{Ai}(x) e^{\gamma\eta\omega^2 x} dx,$$

$$R_B = \omega^2 \int_0^\infty \frac{\text{Ai}'(m\omega^2\xi+x)}{\text{Ai}(m\omega^2\xi+x)} \text{Ai}(x) e^{\gamma\eta\omega x} dx,$$

$$R_C = -\omega^2 \int_0^\infty \frac{\text{Ai}'(m\omega\xi+\omega x)}{\text{Ai}(m\omega\xi+\omega x)} \text{Ai}(\omega x) e^{\gamma\eta x} dx,$$

$$R_D = -\omega \int_0^\infty \frac{\text{Ai}'(m\omega^2\xi+\omega^2 x)}{\text{Ai}(m\omega^2\xi+\omega^2 x)} \text{Ai}(\omega^2 x) e^{\gamma\eta x} dx.$$

For $\eta > 0$ the greatest contribution comes from R_C and R_D . Taking these terms together and making use of the asymptotic property

$$\frac{Ai'(p)}{Ai(p)} \approx -\sqrt{p} + o(p^{-1}) \quad \text{for } |p| \gg 1,$$

we obtain

$$R_C + R_D \approx - \int_0^{\infty} \sqrt{m\xi+x} \{ \omega Ai(\omega x) + \omega^2 Ai(\omega^2 x) \} e^{\gamma \eta x} dx.$$

With (A.7) this form is reduced to

$$(B.3) \quad R_C + R_D \approx \int_0^{\infty} \sqrt{m\xi+x} Ai(x) e^{\gamma \eta x} dx.$$

Application of the saddle-point method leads to asymptotic formula (B.1).

For $\eta < 0$ R_A and R_B dominate and behave like (B.3).

For the proof that

$$R(\xi, \eta) = -\eta + 2\eta \exp\left\{-\xi\eta \frac{r(0)-r_2(0)}{c_0 r(0)}\right\}, \quad \xi\eta = o(1), \eta \gg 1,$$

the reader is referred to [31].

APPENDIX C

In this appendix it is shown, that

$$R(\xi, \eta) = \eta + \frac{\xi^2}{2r(0)c_0} \quad \text{for } \eta/\xi^2 = o(1) \text{ and } 0 < \xi \ll 1.$$

The integrands of (A.6) are expanded to ξ

$$R(\xi, \eta) = -m^{-2} \exp\{-1/2\alpha\xi\eta - 1/12\beta\eta^3\} \{\phi_A + \phi_B + \phi_C + \phi_D\},$$

$$\phi_A = \omega \int_0^{\infty} Ai'(x) \left\{ 1 - n\omega\xi \frac{Ai'(x)}{Ai(x)} + \frac{1}{2} m^2 \omega^2 \xi^2 \frac{Ai''(x)}{Ai(x)} + \dots \right\} e^{\gamma \eta x \omega^2} dx,$$

$$\phi_B = \omega^2 \int_0^\infty \text{Ai}'(x) \left\{ 1 - m\omega^2 \xi \frac{\text{Ai}'(x)}{\text{Ai}(x)} + \frac{1}{2} m^2 \omega \xi^2 \frac{\text{Ai}''(x)}{\text{Ai}(x)} + \dots \right\} e^{\gamma \eta x \omega} dx,$$

$$\phi_C = -\omega^2 \int_0^\infty \text{Ai}'(\omega x) \left\{ 1 - m\omega \xi \frac{\text{Ai}'(\omega x)}{\text{Ai}(\omega x)} + \frac{1}{2} m^2 \omega^2 \xi^2 \frac{\text{Ai}''(\omega x)}{\text{Ai}(\omega x)} + \dots \right\} e^{\gamma \eta x} dx,$$

$$\phi_D = -\omega \int_0^\infty \text{Ai}'(\omega^2 x) \left\{ 1 - m\omega^2 \xi \frac{\text{Ai}'(\omega^2 x)}{\text{Ai}(\omega^2 x)} + \frac{1}{2} m^2 \omega \xi^2 \frac{\text{Ai}''(\omega^2 x)}{\text{Ai}(\omega^2 x)} + \dots \right\} e^{\gamma \eta x} dx.$$

Let these developments to ξ be represented by

$$\phi_A = \phi_A^{(1)} + \phi_A^{(2)} + \phi_A^{(3)} + \dots,$$

$$\dots \dots \dots$$

$$\phi_D = \phi_D^{(1)} + \phi_D^{(2)} + \phi_D^{(3)} + \dots,$$

then for small ξ

$$R(\xi, \eta) = R^{(1)}(\xi, \eta) + R^{(2)}(\xi, \eta) + R^{(3)}(\xi, \eta) + \dots,$$

$$R^{(n)}(\xi, \eta) = m^{-2} \exp\{-1/2\alpha\xi\eta - 1/12\beta\eta^3\} \{\phi_A^{(n)} + \phi_B^{(n)} + \phi_C^{(n)} + \phi_D^{(n)}\}.$$

Using (A.8) and (A.9) we obtain

$$R^{(1)}(\xi, \eta) = \eta + o(\xi^3).$$

$$\phi_A^{(2)} + \phi_B^{(2)} = m\xi \int_0^\infty \frac{\{\text{Ai}'(x)\}^2}{\text{Ai}(x)} \{-\omega^2 e^{\gamma \eta x \omega^2} - \omega e^{\gamma \eta x \omega}\} dx,$$

$$\phi_C^{(2)} + \phi_D^{(2)} = m\xi \int_0^\infty \left| \frac{\{\text{Ai}'(\omega x)\}^2}{\text{Ai}(\omega x)} + \frac{\{\text{Ai}'(\omega^2 x)\}^2}{\text{Ai}(\omega^2 x)} \right| e^{\gamma \eta x} dx.$$

The function $P(x) = - \int_0^\infty \frac{\{\text{Ai}'(s)\}^2}{\text{Ai}(s)} ds$ is introduced, so that

$$P(z) = -\int_z^\infty \left\{ \frac{Ai'(s)}{Ai(s)} \right\}^2 Ai(s) ds \approx -\int_z^\infty s Ai(s) ds = -\int_z^\infty Ai''(s) ds = Ai'(z)$$

for an integration path $s = R(\sigma) e^{i\phi(\sigma)}$ with $R(\sigma) \gg 1$ and $0 \leq |\phi(\sigma)| < \pi$.

$$\begin{aligned} \phi_A^{(2)} + \phi_B^{(2)} &= m\xi \left[\{-\omega^2 e^{\gamma\eta x \omega^2} - \omega e^{\gamma\eta x \omega}\} P(x) \right]_0^\infty + \\ &\quad - m\gamma\xi\eta \int_0^\infty P(x) \{-\omega e^{\gamma\eta x \omega^2} - \omega^2 e^{\gamma\eta x \omega}\} dx, \end{aligned}$$

$$\begin{aligned} \phi_C^{(2)} + \phi_D^{(2)} &= m\xi \left[e^{\gamma\eta x} \{\omega^2 P(\omega x) + \omega P(\omega^2 x)\} \right]_0^\infty + \\ &\quad - m\gamma\xi\eta \int_0^\infty \{P(\omega x)\omega^2 + P(\omega^2 x)\omega\} e^{\gamma\eta x} dx. \end{aligned}$$

It is easily verified that

$$R^{(2)}(\xi, \eta) = O(\xi^3).$$

$$\phi_A^{(3)} + \phi_B^{(3)} = \frac{1}{2} m^2 \xi^2 \int_0^\infty x Ai'(x) \{e^{\gamma\eta x \omega^2} + e^{\gamma\eta x \omega}\} dx,$$

$$\phi_C^{(3)} + \phi_D^{(3)} = \frac{1}{2} m^2 \xi^2 \int_0^\infty x \{-\omega^2 Ai'(\omega x) - \omega Ai'(\omega^2 x)\} e^{\gamma\eta x} dx.$$

$$R^{(3)}(\xi, \eta) = -\frac{1}{2} \xi^2 \exp(-1/2\alpha\xi\eta - 1/12\beta\eta^3) \int_0^\infty x Ai'(x) \{e^{\gamma\eta x} + e^{\gamma\eta x \omega} + e^{\gamma\eta x \omega^2}\} dx.$$

Partial integration yields

$$R^{(3)}(\xi, \eta) = \frac{1}{2} \xi^2 \exp(-1/12\beta\eta^3) \int_0^\infty Ai(x) \{e^{\gamma\eta x} + e^{\gamma\eta x \omega} + e^{\gamma\eta x \omega^2}\} dx + O(\xi^3).$$

Applying the same manipulation as to (A.9) yields

$$R^{(3)}(\xi, \eta) = \frac{\xi^2}{2r(0)c_0} + O(\xi^3).$$

Finally we mention that

$$R^{(n)}(\xi, \eta) = O(\xi^3) \quad \text{for } n = 4, 5, 6, \dots$$

APPENDIX D

In this appendix we prove that

$$\begin{aligned} & h_0 + h_1 \theta + 1/2 h_{\theta\theta} \theta^2 + h_\rho \rho + \\ & (\varepsilon^{-1/3} T_0 + T_1 + \varepsilon^{1/3} T_2) \varepsilon^{1/3} (U_0^{(1/3)} + \bar{V}_0^{(1/3)} + \bar{V}_1^{(1/3)}) + \\ & (\varepsilon^{-1/3} T_0 + T_1) \varepsilon^{2/3} (U_0^{(2/3)} + \bar{V}_0^{(2/3)} + \bar{V}_1^{(2/3)}) + \\ & (\varepsilon^{-1/3} T_0) \varepsilon (U_0^{(3/3)} + \bar{V}_0^{(3/3)} + \bar{V}_1^{(3/3)}) = \\ & \text{Sing}\{L_2 U_0\} + \text{Sing}\{M_2 \bar{V}_0\} + \text{Sing}\{\bar{M}_1 \bar{V}_1\} + Z, \end{aligned}$$

where $Z = O(\varepsilon^N)$ for $1/3\rho_0 < \rho < 2/3\rho_0$, $\varepsilon^{1/3} < \theta < \theta_B - \varepsilon^{1/3}$ and N arbitrary large. $\text{Sing}\{S(x,y;\varepsilon)\}$ denotes the singular terms of a development of $S(x,y;\varepsilon)$ near A (and B), see section 6.3.

Before we prove this relation, some differential operators are introduced. Let $\rho = C\theta^2$ ($C \neq 0$) and $\theta = O(\varepsilon^{1/3})$, then the operators S_1 and S_2 of (6.6) are expanded as follows

$$S_1 \equiv R_{10} + R_{11} + R_{12} + R_{13} + \dots,$$

$$S_2 \equiv R_{20} + R_{21} + R_{22} + R_{23} + \dots,$$

where

$$R_{10} \equiv - \left[\frac{1}{r(0)} \frac{\partial}{\partial \theta} + \left(\frac{r_2(0)}{r(0)} - 1 \right) \theta \frac{\partial}{\partial \theta} \right], \quad R_{11} \equiv - \left[\frac{r_3(0)}{2r(0)} \theta^2 \frac{\partial}{\partial \rho} + g_0 \right],$$

$$\begin{aligned}
R_{12} &\equiv - \left[\left\{ \frac{-1}{2r(0)} \left(1 + \frac{r_2(0)}{r(0)} \right) \theta^2 + \frac{\rho}{r(0)^2} \right\} \frac{\partial}{\partial \theta} + \right. \\
&\quad \left. + \left\{ \frac{r_4(0)}{6r(0)} - \frac{r_2(0)}{2r(0)} \left(1 + \frac{r_2(0)}{r(0)} + \frac{1}{6} \right) \theta^3 + \frac{r_2(0)}{r(0)^2} \rho \theta \right\} \frac{\partial}{\partial \rho} + \varepsilon_1 \theta \right], \\
R_{20} &\equiv c_0 \frac{\partial^2}{\partial \rho^2}, \quad R_{21} \equiv \frac{-2b_0}{r(0)} \frac{\partial^2}{\partial \rho \partial \theta} + 2b_0 \left(1 - \frac{r_2(0)}{r(0)} \right) \theta \frac{\partial^2}{\partial \rho^2}, \\
R_{22} &\equiv \frac{a_0}{r(0)^2} \frac{\partial^2}{\partial \theta^2} + 2 \left(\frac{a_0 r_2(0)}{r(0)^2} - \frac{a_0 - c_0}{r(0)} \right) \theta \frac{\partial^2}{\partial \rho \partial \theta} + \left\{ \left(\frac{a_0 r_2(0)^2}{r(0)^2} - \right. \right. \\
&\quad \left. \left. - \frac{2r_2(0)(a_0 - c_0) + r_3(0)b_0}{r(0)} + (a_0 - c_0) \right) \theta^2 + c_\rho \rho \right\} \frac{\partial^2}{\partial \rho^2} + \\
&\quad + \left(\frac{a_0 r_2(0)}{r(0)^2} - \frac{a_0 + r(0)d_0}{r(0)} - e_0 \right) \frac{\partial}{\partial \rho}.
\end{aligned}$$

Let $\xi = C/\theta$ ($C \neq 0$ and $\rho = \xi \varepsilon$) and $\theta = O(\varepsilon^{1/3})$, then the ordinary boundary layer operators M_i $i = 0, 1, \dots$ are expanded as follows

$$M_0 \equiv P_{00} + P_{01} + P_{02} + \dots,$$

$$M_1 \equiv P_{10} + P_{11} + P_{12} + \dots,$$

$$M_2 \equiv P_{20} + P_{21} + P_{22} + \dots,$$

$$\dots \dots \dots$$

where

$$\begin{aligned}
P_{00} &\equiv c_0 \frac{\partial^2}{\partial \xi^2} - \left(\frac{r_2(0)}{r(0)} - 1 \right) \theta \frac{\partial}{\partial \xi}, \quad P_{01} \equiv 2b_0 \left(1 - \frac{r_2(0)}{r(0)} \right) \theta \frac{\partial^2}{\partial \xi^2} - \frac{r_3(0)}{2r(0)} \theta^2 \frac{\partial}{\partial \xi}, \\
P_{02} &\equiv \left(\frac{a_0 r_2(0)^2}{r(0)^2} - \frac{2r_2(0)(a_0 - c_0) + r_3(0)b_0}{r(0)} + (a_0 - c_0) \right) \theta^2 \frac{\partial^2}{\partial \xi^2} - \frac{r_4(0)}{6r(0)} +
\end{aligned}$$

$$\begin{aligned}
& - \frac{r_2(0)}{2r(0)} \left(1 + \frac{r_2(0)}{r(0)} + \frac{1}{6}\right) \theta^3 \frac{\partial}{\partial \xi}, \quad P_{10} \equiv - \frac{1}{r(0)} \frac{\partial}{\partial \theta}, \\
P_{11} & \equiv - \frac{2b_0}{r(0)} \frac{\partial^2}{\partial \xi \partial \theta} - g_0, \quad P_{12} \equiv 2 \left\{ \frac{a_0 r_2(0)}{r(0)^2} - \frac{a_0 - c_0}{r(0)} \right\} \theta \frac{\partial^2}{\partial \xi \partial \theta} + c_{\xi} \frac{\partial^2}{\partial \xi^2} + \\
& \left\{ \frac{a_0 r_2(0)}{r(0)^2} - \frac{a_0 + r(0)d_0}{r(0)} - e_0 \right\} \frac{\partial}{\partial \xi} + \frac{1}{2r(0)} \left(1 + \frac{r_2(0)}{r(0)}\right) \theta^2 \frac{\partial}{\partial \theta} - \\
& - \frac{r_2(0)}{2r(0)} \xi \theta \frac{\partial}{\partial \xi} - g_1 \theta, \quad P_{20} \equiv P_{21} \equiv 0, \quad P_{22} \equiv \frac{a_0}{r(0)^2} \frac{\partial^2}{\partial \theta^2} - \frac{\xi}{r(0)^2} \frac{\partial}{\partial \theta}.
\end{aligned}$$

It is readily established that between these operators expansions and the intermediate boundary layer operators T_i the following relations exist:

$$(D.1a) \quad T_0 \equiv \varepsilon^{1/3} (R_{10} + \varepsilon R_{20}) \equiv \varepsilon^{-2/3} (P_{00} + \varepsilon P_{10} + \varepsilon^2 P_{20}),$$

$$(D.1b) \quad T_1 \equiv \varepsilon^{2/3} (R_{11} + \varepsilon R_{21}) \equiv \varepsilon^{-1/3} (P_{01} + \varepsilon P_{11} + \varepsilon^2 P_{21}),$$

$$(D.1c) \quad T_2 \equiv \varepsilon (R_{12} + \varepsilon R_{22}) \equiv (P_{01} + \varepsilon P_{12} + \varepsilon^2 P_{22}).$$

Since $S_1 U_0 = h(\rho, \theta)$, we have for ρ and θ sufficiently small the relation

$$\begin{aligned}
& (R_{10} + R_{11} + R_{12} + \dots) (\psi_0 + U_0^{(1/3)} + U_0^{(2/3)} + \dots) = \\
& h_0 + h_1 \theta + 1/2 h_{\theta\theta} \theta^2 + h_{\rho} \rho + \dots
\end{aligned}$$

Equalization of terms of a same order of magnitude yields

$$\begin{aligned}
R_{10}\psi_0 &= 0 \\
R_{11}\psi_0 + R_{10}\epsilon^{1/3}U_0^{(1/3)} &= h_0 \\
R_{12}\psi_0 + R_{11}\epsilon^{1/3}U_0^{(1/3)} + R_{10}\epsilon^{2/3}U_0^{(2/3)} &= h_1\theta \\
R_{13}\psi_0 + R_{12}\epsilon^{1/3}\psi_0 + R_{11}\epsilon^{2/3}U_0^{(2/3)} + R_{10}\epsilon U_0^{(3/3)} &= 1/2h_{\theta\theta}\theta^2 + h_\rho\rho
\end{aligned}$$

$$\begin{aligned}
\text{(D.2)} \quad & (R_{10} + R_{11} + R_{12} + R_{13})\psi_0 + (R_{10} + R_{11} + R_{12})\epsilon^{1/3}U_0^{(1/3)} + \\
& (R_{10} + R_{11})\epsilon^{2/3}U_0^{(2/3)} + R_{10}\epsilon U_0^{(3/3)} = h_0 + h_1\theta + 1/2h_{\theta\theta}\theta^2 + h_\rho\rho.
\end{aligned}$$

Similarly, because $M_0V_0 = 0$ and $M_0V_1 + M_1V_1 = 0$, we have the relations

$$\text{(D.3a)} \quad (P_{00} + P_{01} + P_{02})\epsilon^{1/3}V_0^{(1/3)} + (P_{00} + P_{01})\epsilon^{2/3}V_0^{(2/3)} + P_{00}\epsilon V_0^{(3/3)} = 0$$

$$\begin{aligned}
\text{(D.3b)} \quad & (P_{00} + P_{01} + P_{02})\epsilon^{-2/3}V_1^{(1/3)} + (P_{00} + P_{01})\epsilon^{-1/3}V_1^{(2/3)} + P_{00}V_1^{(3/3)} + \\
& (P_{10} + P_{11} + P_{12})\epsilon^{1/3}V_0^{(1/3)} + (P_{10} + P_{11})\epsilon^{2/3}V_0^{(2/3)} + P_{10}\epsilon V_0^{(3/3)} = 0.
\end{aligned}$$

Formulae (D.1), (D.2) and (D.3) are utilized in order to show that

$$\begin{aligned}
\text{(D.4)} \quad & h_0 + h_1\theta + 1/2h_{\theta\theta}\theta^2 + h_\rho\rho + \\
& (\epsilon^{-1/3}T_0 + T_1 + \epsilon^{1/3}T_2)\epsilon^{1/3}(U_0^{(1/3)} + \bar{V}_0^{(1/3)} + \bar{V}_1^{(1/3)}) + \\
& (\epsilon^{-1/3}T_0 + T_1)\epsilon^{2/3}(U_0^{(2/3)} + \bar{V}_0^{(2/3)} + \bar{V}_1^{(2/3)}) + \\
& (\epsilon^{-1/3}T_0)\epsilon(U_0^{(3/3)} + \bar{V}_0^{(3/3)} + \bar{V}_1^{(3/3)}) = \\
& (R_{20} + R_{21} + R_{22})\epsilon^{1/3}U_0^{(1/3)} + (R_{20} + R_{21})\epsilon^{2/3}U_0^{(2/3)} + R_{20}\epsilon U_0^{(3/3)} + \\
& (P_{20} + P_{21} + P_{22})\epsilon^{4/3}\bar{V}_0^{(1/3)} + (P_{20} + P_{21})\epsilon^{5/3}\bar{V}_0^{(2/3)} + P_{20}\epsilon^2\bar{V}_0^{(3/3)} +
\end{aligned}$$

$$(P_{10} + P_{11} + P_{12}) \varepsilon^{1/3} \bar{V}_1^{-(1/3)} + (P_{10} + P_{11}) \varepsilon^{2/3} \bar{V}_1^{-(2/3)} + P_{10} \varepsilon \bar{V}_1^{-(3/3)} + Z,$$

where

$$Z = O(\varepsilon^N) \quad \text{for } 1/3\rho_0 \leq \rho \leq 2/3\rho_0, \quad \varepsilon^{1/3} < \theta < \theta_B - \varepsilon^{1/3},$$

$$Z = 0 \quad \text{elsewhere in } \bar{G}.$$

The right-hand side of (D.4) cancels the singular terms of $L_2 U_0$, $\bar{M}_2 \bar{V}_0$ and $\bar{M}_1 \bar{V}_1$.

REFERENCES

- [1] G.F. CARRIER Boundary layer problems in applied mechanics. 1953, Advances in Applied Mechanics vol. 3, p. 1-19.
- [2] J.D. COLE, P.A. LAGERSTRÖM Examples illustrating expansion procedures for the Navier-Stokes equations. 1955, Journal of Rational Mechanics and Analysis vol. 4, p. 817.
- [3] J.D. COLE Perturbation methods in applied mathematics. 1968, Blaisdell Publishing Company.
- [4] W. ECKHAUS On the structure of certain asymptotic boundary layers. 1968, Report Mathematical Institute of Delft University of Technology.
- [5] W. ECKHAUS On the foundations of the method of matched asymptotic approximations. 1969, Journal de Mécanique vol. 8, p. 265-300.
- [6] W. ECKHAUS Boundary layers in linear elliptic singular perturbation problems. 1971, Report Mathematical Institute of Delft University of Technology.
- [7] W. ECKHAUS, E.M. DE JAGER Asymptotic solutions of singular perturbation problems for linear differential equations. 1966, Archive for Rational Mechanics and Analysis vol. 23, p. 26-86.
- [8] A. ERDÉLYI Singular Perturbations. 1962, Bulletin of the American Mathematical Society vol. 68, p. 420-424.
- [9] A. ERDÉLYI Approximate solutions of a non-linear boundary value problem. 1968, Archive for Rational mechanics and Analysis vol. 29, p. 1-17.

- [10] L.E. FRAENKEL On the method of matched asymptotic expansions. 1969, Proceedings of the Cambridge Philosophical Society vol. 65, p. 209.
- [11] J.F. FRANKENA A uniform asymptotic expansion of the solution of a linear elliptic singular perturbation problem. 1968, Archive for Rational Mechanics and Analysis vol. 31, no. 3.
- [12] K.O. FRIEDRICHS Asymptotic phenomena in mathematical physics. 1955, Bulletin of the American Mathematical Society vol. 61, p. 485-501.
- [13] R.R. GOLD Magenetohydrodynamic pipe flow, part I. 1962, Journal of Fluid dynamics, vol. 13, p. 505-512.
- [14] J. GRASMAN On singular perturbations and parabolic boundary layers. 1968, Journal of Engineering Mathematics vol. 2, no. 2, p. 163-172.
- [15] J. GRASMAN Uniformly valid approximations and the singular perturbation method. 1969, report TW 111, Mathematical Centre, Amsterdam.
- [16] J. GRASMAN A linear elliptic singular perturbation problem. 1970, report TW 121, Mathematical Centre, Amsterdam.
- [17] P.P.N. DE GROEN An elliptic boundary value problem with non-differential parameters. 1970, report ZW 001, Mathematical Centre, Amsterdam.
- [18] S. KAPLUN The role of coordinate systems in boundary layer theory. 1954, Zeitschrift für angewandte Mathematik und Physik vol. 5, p. 111-135.
- [19] S. KAPLUN, P.A. LAGERSTRÖM Asymptotic expansions of Navier-Stokes solutions for small Re-numbers. 1957, Journal of Mathematics and Mechanics vol. 6, p. 585.

- [20] J.K. KNOWLES, R.E. MESSICK
On a class of singular perturbation problems. 1964, Journal of Mathematical Analysis and Applications vol. 9.
- [21] N. LEVINSON
The first boundary value problem. 1950, Annals of Mathematics vol. 51.
- [22] J.J. MAHONY
An expansion method for singular perturbation problems. 1961, Journal of the Australian Mathematical Society vol. 2, p. 444-470.
- [23] R.E. O'MALLEY
Topics in singular perturbations. 1968, Advances in Mathematics vol. 2.
- [24] J. MAUSS
Estimation de la solution d'un problème aux limites elliptique. 1967, C.R. Academie des Sciences, Paris vol. 265, p. 728-730 (ser.A).
- [25] J. MAUSS
Étude de la solution asymptotique du problème de la couche limite parabolique. 1967, C.R. Academie des Sciences, Paris vol. 265, p. 838-840 (ser.A).
- [26] J. MAUSS
Structure de la solution asymptotique au voisinage des points singuliers, dans un domaine non convexe pour un problème de perturbations singulieres de type elliptique. 1969, C.R. Academie des Sciences, Paris vol. 268, p. 275-277 (ser.A).
- [27] J. MAUSS
Approximation asymptotique uniforme de la solution d'un problème de perturbation singuliere de type elliptique. 1969, Journal de Mécanique vol. 8, p. 373-393.
- [28] J. MAUSS
Comportement asymptotique des solutions de problèmes de perturbation singuliere pour une équation de type elliptique. 1970, Journal de Mécanique vol. 9, no. 4, p. 523-556.

- [29] J.D. MURRAY A simple method for determining asymptotic forms of Navier-Stokes solutions for a class of large Reynolds number flows. 1967, Journal of Mathematics and Physics vol. 46, no. 1, p. 1-20.
- [30] M.H. PROTTER, H.F. WEINBERGER
 Maximum principles in differential equations. 1967, Prentice Hall, New Jersey.
- [31] P.H. ROBERTS Singularities of Hartmann layers. 1967, Proceedings of the Royal Society vol. 300 (ser.A).
- [32] J. SHERCLIFF Magnetohydrodynamic pipe flow, part II, High Hartmann number. 1962, Journal of Fluid dynamics vol. 13, p. 513-518.
- [33] N.M. TEMME Analytical methods for a singular perturbation problem. The quarter plane. 1971, report TW 125, Mathematical Centre, Amsterdam.
- [34] M.I. VISIK, L.A. LYUSTERNIK
 Regular degeneration and boundary layer for linear differential equations with small parameter, 1957, Uspehi Matematika Nauk vol. 12. (1962, American Mathematical Society Translation Series 2, vol. 20.)
- [35] W. WASOW Asymptotic solution of boundary value problems for the differential equation

$$\Delta U - \lambda \frac{\partial u}{\partial x} = \lambda f(x,y).$$
 1944, Duke Mathematical Journal vol. 11.

INDEX

Airy function	102	Generalized limit	14
Asymptotic equality	5	Green's function	87
Asymptotic equivalence	7	Green's theorem	83
Barrier-function	28, 38	Hartmann number	118
Boundary layer level	73	Induction equation	117
Boundary layers		Initial value problem	27
interior boundary layer	104	Iteration process	93
intermediate boundary layer	99	Limit function	12, 52
multiple boundary layer	19, 42	Local approximation	90
ordinary boundary layer	98	Local coordinates	54
parabolic boundary layer	85	Magnetohydrodynamical problem	117
Boundary value problem	37	Magnetic field	117
Characteristic	43, 50, 91	Matching theorem	15, 55
Differential equations		Matching principle	15, 57
elliptic differential equation		Maximum principle	28
	43, 90, 104	Modified Bessel function	83
ordinary differential equation		Navier-Stokes equation	117
	28, 37, 98	Non-uniform convergence	9
parabolic differential equation		Order functions	5
	100, 115	Path	13
Elliptic problem	43	Significant limit function	60
Exact solution	83	Smoothing factor	47, 107
Extension theorem	11, 51	Successive approximations	27
Flux	119	Tangency	
Functions		first order tangency	91
explicitly given function	27	higher order tangency	113
implicitly defined function	27	Taylor series	102
regular function	7	Uniformly valid expansion	106
singular function	7		
Formal limit function	33, 48		
Formal local approximation	92		